



Drehen	<ul style="list-style-type: none">■ Schneidplatten■ Schaftwerkzeuge■ Werkzeugaufnahmen■ Sonderwerkzeuge■ Diamantschneidplatten positiv	<ul style="list-style-type: none">■ Schneidplatten beschichtet■ MKD- und Naturdiamant-Werkzeuge■ Gelaserte Schneidplatten■ Stechwerkzeuge	1
Fräsen	<ul style="list-style-type: none">■ Fräsplatten■ Finger- und Radiusfräser■ Vielzahnfräser■ Fräskopfeinsätze■ Diamantfräser gelasert■ Fräskopf	<ul style="list-style-type: none">■ Kugelfräser■ Aufsteckfräser■ Scheibenfräser■ Gravierstichel■ CVD-Diamant Bohrer■ Glanzfräser	2
Abrichten	<ul style="list-style-type: none">■ DIAROLL-Abrichter■ DIALETTEN-Abrichter■ Vielkornabrichter■ Abrichtleisten■ Handabrichter■ Einkornabrichter	<ul style="list-style-type: none">■ Minenabrichter■ Dreieck- und Profilaabrichter■ WEISS DRESSER und Abrichtwelle■ Wendeplatten-Abrichter■ M-Dresser	3
Schleifen	<ul style="list-style-type: none">■ Diamant- und CBN-Schleif-scheiben■ Korund- und Siliziumkar-bidscheiben		4
Messen und Prüfen	<ul style="list-style-type: none">■ Härteprüfdiamanten■ Diamant-Messtaster		5
Polieren und Läppen	<ul style="list-style-type: none">■ Diamant-Poliermittel■ Diamant-Handläpper		6
Feilen	<ul style="list-style-type: none">■ Diamant-Handfeilen■ Diamant-Maschinenfeilen		7
Dienstleistungen	<ul style="list-style-type: none">■ Laserbearbeitung■ Hartlöten mittels Induktion■ Drahterodieren■ Nachschleifservice		8
Allgemeines	<ul style="list-style-type: none">■ Bestellvorgang■ Kontaktdaten■ Wir über uns■ Zertifizierung■ Impressum		9
Preisliste / AGB			10

Einleitung

■ Übersicht und Auswahlhilfe Schneidplatten	1-2
■ Produktauswahl nach Anwendung / Schneidengeometrie / Schnittwerte	1-3
■ Einführung in die Schneidwerkstoffe	1-4
■ ISO-Bezeichnung	1-8

Schneidplatten mit BORAPACT(CBN)-Schneiden

■ Produktübersicht	1-10
■ ISO-Schneidplatten, Anwendung Innen	
■ Ausführung Mehrweg	1-11
■ Ausführung Einweg	1-13
■ Ausführung Einweg - Doppelseitig	1-14
■ Ausführung Vollbelag	1-15
■ ISO-Schneidplatten, Anwendung Aussen	
■ Ausführung Mehrweg	1-16
■ Ausführung Einweg	1-19
■ Ausführung Einweg - Doppelseitig	1-20
■ Ausführung Vollbelag	1-21
■ Ausführung Massivplatte	1-22
■ Einweg BORAPACT(CBN)-Schneidplatten beschichtet	1-24

Schneidplatten mit Diamant-Schneiden

■ Produktübersicht	1-28
■ ISO-Schneidplatten, Anwendung Innen	
■ Ausführung Mehrweg	1-29
■ Ausführung Mehrweg positiv	1-31
■ Ausführung Einweg	1-32
■ Ausführung Einweg - Doppelseitig	1-33
■ Ausführung Vollbelag	1-34
■ ISO-Schneidplatten, Anwendung Aussen	
■ Ausführung Mehrweg	1-36
■ Ausführung Einweg	1-38
■ Ausführung Einweg - Doppelseitig	1-39
■ ISO-Schneidplatten, CVD-Diamant gelasert	
■ Ausführung Einweg	1-41
■ Ausführung Mehrweg positiv	1-42
■ Naturdiamant und MKD-Werkzeuge	1-81

Schaftwerkzeuge

■ Produktübersicht	1-44
■ Mit BORAPACT(CBN)-Schneiden, für Innenbearbeitung	
■ Anwendung Ausbohren	1-45
■ Anwendung Sacklochbohren	1-46
■ Mit BORAPACT(CBN)-Schneiden, für Aussenbearbeitung	
■ Anwendung Längsdrehen	1-47
■ Anwendung Plan- und Längsdrehen	1-48
■ Anwendung Ein- und Abstechen	1-49
■ Mit Diamant-Schneiden, für Innenbearbeitung	
■ Anwendung Ausbohren	1-50
■ Anwendung Sacklochbohren	1-51

■ Mit Diamant-Schneiden, für Aussenbearbeitung	
■ Anwendung Längsdrehen	1-52
■ Anwendung Plan- und Längsdrehen	1-53
■ Anwendung Ein- und Abstechen	1-54

Werkzeugaufnahmen

■ Produktübersicht	1-56
■ Klemmhalter	
■ Mit Spannpratzenspannung	1-57
■ Mit Kniehebelspannung	1-58
■ Mit Schraubenspannung	1-60
■ Für Innendrehstahl 2125	1-63
■ Für Schältschneidplatte R 9.52	1-64
■ Für Kollektorschneidplatte	1-65
■ Bohrstangen	
■ Mit Kniehebelspannung	1-66
■ S-Bohrstangen	
■ Mit Schraubenspannung für Innenbearbeitung	1-68
■ VHM-Bohrstangen	
■ Mit Schraubenspannung für Innenbearbeitung mit Innenkühlung	1-71
■ Bohrstangen	
■ Für Bohrstangeneinsatz 2870 Typ A und B	1-73

Sonderwerkzeuge

■ Produktübersicht Presspolierdiamant	1-74
■ Presspolierdiamant	1-75
■ Produktübersicht Kollektor-Werkzeuge	1-76
■ DIAPACT(PKD)-Kollektor-Schäldrehwerkzeug und -Schältschneidplatten	1-77
■ DIAPACT(PKD)-Kollektor-Drehwerkzeug	1-78
■ Abstech-, Einstech- und Kopier- Drehwerkzeuge	
■ Klemmhalter	1-89
■ Einsätze	1-93



Übersicht ISO-Schneidplatten mit BORAPACT(CBN)-Schneiden

Anwendung	Typ in Schneidenausführung					
	Mehrweg	Einweg	Einweg Doppelseitig	Vollbelag	Massivplatte	Einweg beschichtet
Innen	CCMW.....→1-11	CCMW.....→1-13	CCMW.....→1-14	TPUN.....→1-15	-	CCGW.....→1-26
	DCMW.....→1-11	DCMW.....→1-13	DCMW.....→1-14			DCGW.....→1-26
	TCMW.....→1-11	TPUN.....→1-13	VCMW.....→1-14			TCGW.....→1-26
	TPMW.....→1-12	VCMW.....→1-13				VCMW.....→1-26
	TPUN.....→1-12					
	VCMW.....→1-12					
Aussen	CCMW.....→1-16	CCMW.....→1-19	CCMW.....→1-20	RNUN.....→1-21	CNMN.....→1-22	CNGA.....→1-27
	CNMA.....→1-16	CNMA.....→1-19	CNMA.....→1-20	SNUN.....→1-21	RNMN.....→1-22	SNGA.....→1-27
	DNMA.....→1-16	SNUN.....→1-19	SNUN.....→1-20	TNUN.....→1-21	SNMN.....→1-22	TNGA.....→1-27
	SCMW.....→1-16	TNMA.....→1-19	VBMW.....→1-20		TNMN.....→1-22	VBMW.....→1-27
	SNMA.....→1-17	VBMW.....→1-19				
	SNUN.....→1-17					
	TNMA.....→1-17					
	TNUN.....→1-18					
	VBMW.....→1-18					
	VNMA.....→1-18					

Übersicht ISO-Schneidplatten mit Diamant-Schneiden

Anwendung	Typ in Schneidenausführung						
	Mehrweg	Mehrweg positiv	Mehrweg CVD positiv	Einweg	Einweg CVD gelasert	Einweg Doppelseitig	Vollbelag
Innen	CCMW...→1-29	-	DCGT (N)..→1-42	CCMW...→1-32	CCGW...→1-41	CCMW...→1-33	TPUN..→1-34
	CPGW...→1-29		VCGT (N)..→1-42	CPGW...→1-32	CPGW...→1-41	CPGW...→1-33	
	DCMW...→1-29		DCGT R/L →1-42	DCMW...→1-32	DCGW...→1-41	DCMW...→1-33	
	TCMW...→1-29		VCGT R/L →1-42	TPUN...→1-32	VCGW...→1-41	VCMW...→1-33	
	TPMW...→1-30			VCMW...→1-32			
	TPUN...→1-30						
	VCMW...→1-30						
Aussen	CCMW...→1-36	DCMT.....→1-31	DCGT (N)..→1-42	CCMW...→1-38	CCGW...→1-41	CCMW...→1-39	-
	CPGW...→1-36	VCMT.....→1-31	VCGT (N)..→1-42	SCMW...→1-38	CPGW...→1-41	SCMW...→1-39	
	DCMW...→1-36	DCMT.....→1-31	DCGT R/L →1-42	SPUN...→1-38	DCGW...→1-41	SPUN...→1-39	
	SCMW...→1-36	VCMT.....→1-31	VCGT R/L →1-42		VCGW...→1-41		
	SPUN...→1-37						



Drehen

Produktauswahl nach Anwendung

Anwendung	Bezeichnung	Sortenübersicht	Eigenschaften
Schruppen und Schichten von gehärteten Stählen ab 45 HRc bis 70 HRc	BORAPACT (CBN)	B010 B020 B040 B050 B060 B070 B075 B080	Hohe Abriebfestigkeit, hervorragende Schlagfestigkeit, ausgezeichnete Schneidkantenqualität und -stabilität. Feine Oberflächengüten, höchste Wärmebeständigkeit
Schruppen und Schichten aller NE-Metalle, Kunststoffe je nach Sorte mit mehr oder weniger abrasiven Füllstoffen, Hartmetall, Keramik, Platin, Gold	DIAPACT (PKD)	A010 A020 A030 A040	Mit Hartmetallunterlage, hohe Abriebfestigkeit, gute bis sehr gute Schneidenqualität
Schruppen und Schichten von abrasiven NE-Metallen, Kunststoffen mit abrasiven Füllstoffen, Grafit, Hartmetall, Keramikgrünlingen	CVD-Diamant	A060	Ohne Hartmetallunterlage und ohne metallische Bindephease, 99,9% Diamantanteil, scharfenfreie Schneidkanten, höchste Verschleissfestigkeit, hohe Wärmeleitfähigkeit
Schichten von NE-Metallen, Kunststoffen ohne abrasive Füllstoffe, Edelmetallen, Acrylglas, allgemein für Hochglanzbearbeitungen und feinste Oberflächengüten	MKD	A070	Synthetische, monokristalline Diamantplatten, synthetischer Einkristalldiamant, höchste Härte, höchste Schneidenschärfe, vordefinierte Schnittkraftfrichtung, geringe Bruchzähigkeit
	Naturdiamant	A080	Naturdiamant, höchste Härte, höchste Schneidenschärfe, geringe Bruchzähigkeit

Wahl der Schneidengeometrie

Die Wahl der optimalen Schneidengeometrie an der Werkzeug-schneide ist entscheidend für lange Standzeiten, hohe Oberflächengüte und kurze Fertigungszeiten.

- Freiwinkel α
Verringerung der Reibung
- Keilwinkel β
Je weicher der zu bearbeitende Werkstoff, desto kleiner ist der Keilwinkel zu wählen, umso geringer ist die Gratbildung, aber auch die Standzeit der Schneide
- Spanwinkel γ
Je weicher der zu bearbeitende Werkstoff, desto grösser ist der Spanwinkel zu wählen. Harte oder spröde Werkstoffe erfordern dagegen keine oder sogar negative Spanwinkel

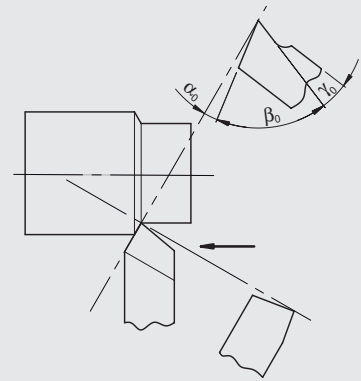

Schnittwerte

Die Schnittgeschwindigkeit und die Vorschubgeschwindigkeit überlagern sich und führen zu einem kontinuierlichen Zerspanungsvorgang.

- Schnittgeschwindigkeit [m/min]

$$V_c = \frac{D \times \pi \times n}{1000}$$

D Drehdurchmesser [mm]

n Drehzahl [U/min]

V_c Schnittgeschwindigkeit [m/min]

- Drehzahl [U/min]

$$n = \frac{V_c \times 1000}{D \times \pi}$$

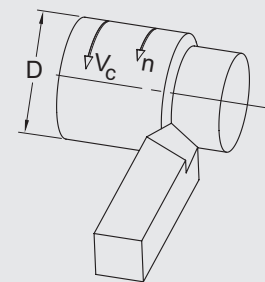



Einführung

Die moderne industrielle Gesellschaft verlangt nach immer fortschrittlicheren Materialien, dies hat die zerspanende Industrie zu neuen Produkten und Erkenntnissen geführt. Durch die Verbesserung der Produktionsprozesse und die Schwierigkeiten, die aus der Bearbeitung von moderneren Produkten resultieren, erhöhte sich der Bedarf an Formen von Schneidwerkzeugen, die mit konventionellen Werkstoffen wie HSS, Hartmetall, Sintermetall und Keramik nicht umsetzbar sind.

Heute sind Diamant- und CBN-Werkzeuge aus dem Fertigungsprozess der Industrie nicht mehr wegzudenken. Durch die Entwicklung von Schneidstoffen wie MKD, CVD-Diamant und die Entwicklung von zusätzlichen PKD- und CBN-Sorten konnte das Lieferprogramm an Schneidwerkzeugen vergrößert werden.

Heute werden Diamant- und CBN-Werkzeuge jeglicher Art mit modernsten Maschinen und Messtechniken hergestellt.

Grundsätzliche Übersicht der verschiedenen Hartschneidstoffe

Schneidstoff	Anwendung	Aufbau	Details
BORAPACT (CBN)	Bearbeitung von gehärteten Stählen ab 45 HRc bis 70 HRc	Polykristallines, kubisches Bornitrid mit Hartmetallsubstrat oder Keramikmatrix. Kubisches Bornitrid (CBN) ist nach Diamant der härteste aller bekannten Stoffe. Es wird mit Hilfe eines als Hochdruck-Hochtemperatur (HDT)-Synthese bezeichneten Prozesses aus hexagonalem Bornitrid (CBN) hergestellt.	→ Seite 1-5
Diamant-Schneiden	DIAPACT (PKD)	Fein- und Feinstbearbeitung von NE-Metallen	→ Seite 1-6
	CVD-Diamant	Bearbeitung von abrasiven NE-Metallen	→ Seite 1-7
	MKD	Einsatz zum Glanzdrehen und Fräsen von Edelmetallen	→ Seite 1-7
	Naturdiamant	Einsatz zum Glanzdrehen und Fräsen von Edelmetallen für höchste Ansprüche	→ Seite 1-7

Härtevergleichstabelle

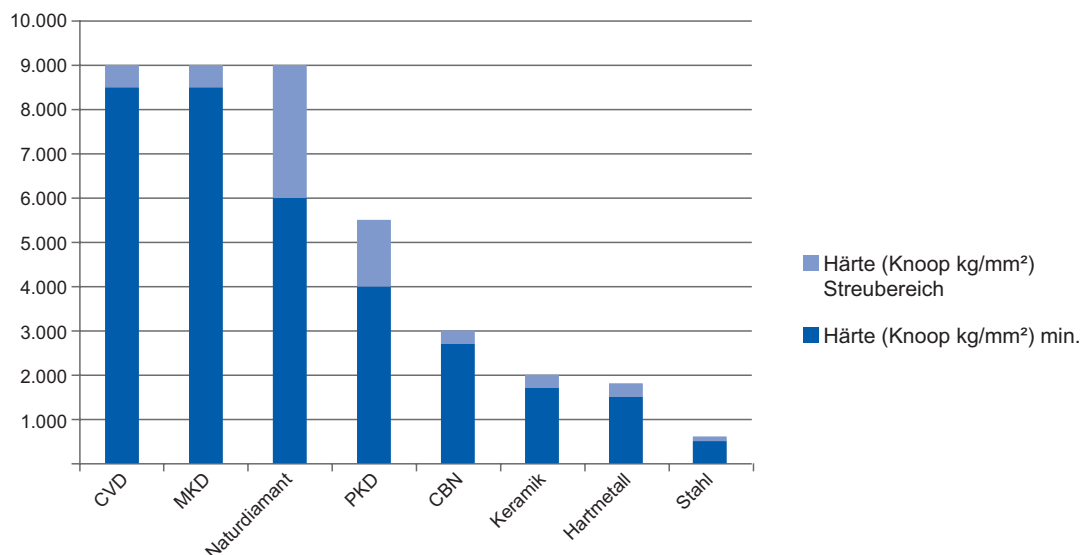

BORAPACT (CBN)–Schneidwerkstoffe
Wichtige Hinweise für den Einsatz von BORAPACT (CBN)-Schneidwerkstoffen

- Einsatz nur auf Maschinen mit hoher Stabilität und ausreichender Antriebsleistung
- Grosser Schneidradius für erhöhte Schlagfestigkeit
- Wenn immer möglich, negative Spanwinkel sowie grossen Werkzeuganstellwinkel verwenden
- Werkzeughalter so kurz wie möglich spannen
- Kantenfasen mit zusätzlicher verrundeter Schneidkante erhöhen die Kantenstabilität bei unterbrochenem Schnitt
- Schneideinsätze können ausbrechen, wenn die Maschine im Schnitt angehalten wird oder die Schneidkante trotz fortgeschrittenem Verschleiss nicht indexiert wird
- Bei Anwendungen mit unterbrochenem Schnitt kein Kühlmittel verwenden

Sortimentsübersicht und Schnittdatenempfehlung

Sorte	Hauptanwendung	Schnittgeschwindigkeit V [m/min]	Vorschub [mm/U]	Schnitttiefe [mm]
B010	■ Perlitischer Grauguss	600 – 1500	0.15 – 0.60	0.10 – 2.50
	■ Werkzeug- und Formbaustähle	60 – 90	0.10 – 0.20	0.10 – 0.50
	■ Aufspritz-/Aufschweislegierungen	100 – 300	0.10 – 0.25	0.10 – 1.50
	■ Pulvermetallurgische Eisenwerkstoffe	90 – 180	0.10 – 0.25	0.10 – 1.30
	■ Schichten von Superlegierungen auf Ni/Cr-Basis	150 – 250	0.10 – 0.30	0.10 – 0.40
B020	■ Werkzeugstähle (kontinuierlicher bis leicht unterbrochener Schnitt)	100 – 200	0.10 – 0.30	0.10 – 0.30
	■ Legierungsstähle	80 – 200	0.10 – 0.30	0.10 – 0.30
	■ Oberflächengehärtete Stähle (kontinuierlicher bis leicht unterbrochener Schnitt)	80 – 200	0.10 – 0.30	0.10 – 0.30
	■ Werkzeug-Legierungsstähle (stark unrunde Werkstücke und unterbrochene Schnitte)	70 – 110	0.15 – 0.60	0.15 – 0.60
B040	■ Pulvermetallurgische Eisenlegierungen	60 – 200	0.10 – 0.25	0.10 – 0.30
B050	■ Gusseisen	600 – 1200	0.15 – 0.50	0.10 – 0.25
	■ PM Fe-Legierungen	90 – 180	0.10 – 0.20	0.10 – 1.00
	■ Gehärteter Stahl	200 – 400	0.10 – 0.20	0.10 – 1.00
	■ Werkzeug- und Formenbaustähle drehen	90 – 120	0.10 – 0.20	0.10 – 1.00
	■ Kontur / Finish fräsen	200 – 400	0.10 – 0.20	0.10 – 1.00
B060 Anwendung in erster Linie für das Schlichten im kontinuierlichen Schnitt	■ Gehärtete Stahllegierungen (>45 HRC)	140 – 250	0.05 – 0.20	0.10 – 0.25
	■ Werkzeug- und Formbaustähle	80 – 140	0.15 – 0.20	0.10 – 0.25
B070	■ Einsatz-, Vergütungs- und legierte Stähle, unterbrochener Schnitt	120 – 200	0.10 – 0.20	0.10 – 0.50
	■ Werkzeugstähle	80 – 120	0.10 – 0.20	0.10 – 0.50
B075	■ Gehärteter Guss/Hartschalenguss (>45 HRC)	40 – 100	0.10 – 0.60	0.10 – 2.50
	■ Gehärtete Stahllegierungen	65 – 120	0.10 – 0.50	0.50 – 2.50
	■ Perlitischer Grauguss	600 – 1200	0.15 – 0.60	0.10 – 2.50
	■ Aufspritzlegierungen	50 – 200	0.10 – 0.25	0.10 – 1.50
	■ Pulvermetallurgische Legierungen auf Eisenbasis	90 – 180	0.10 – 0.25	0.10 – 1.30
B080	■ Werkzeugstähle (kontinuierlicher bis leicht unterbrochener Schnitt)	100 – 200	0.10 – 0.30	0.10 – 0.30
	■ Legierungsstähle	80 – 200	0.10 – 0.30	0.10 – 0.30
	■ Oberflächengehärtete Stähle (kontinuierlicher bis leicht unterbrochener Schnitt)	80 – 200	0.10 – 0.30	0.10 – 0.30
	■ Werkzeug-Legierungsstähle (stark unrunde Werkstücke und unterbrochene Schnitte)	70 – 110	0.15 – 0.60	0.15 – 0.60



DIAPACT (PKD)-Schneidwerkstoffe

Wichtige Hinweise für den Einsatz von DIAPACT (PKD)-Schneidwerkstoffen

- Schneiden aufgrund von Ausbruchgefahr nicht mechanisch vermessen
- Für unterbrochenen Schnitt Schnittwerte ca. halbieren
- Intensive Kühlung mit leichter Bohremulsion verbessert die Schnittleistung erheblich
- Bei den meisten Anwendungen ist mit scharf ausgebildeten Schneidkanten zu arbeiten. Bei stark unterbrochenem Schnitt und bei Schrappanwendungen empfiehlt sich eine Schneidkantenverrundung von 0.025 mm zur Verhinderung von Schneidkantenausbruch
- Für einen Grossteil des Anwendungsspektrums kann ein neutraler oder leicht positiver Spanwinkel (5° – 8°) mit einem Freiwinkel (10° – 13°) verwendet werden
- Ein positiver Spanwinkel von 10° – 15° minimiert die Gratbildung bei weichen, duktilen Werkstoffen und optimiert den Spanablauf
- Verwenden Sie einen negativen Spanwinkel von 3° – 5° zur Zerspanung von spröden oder harten Werkstoffen wie gesintertem Hartmetall oder keramischen Werkstoffen

Sortimentsübersicht und Schnittdatenempfehlung

Sorte	Hauptanwendung	Schnittgeschwindigkeit V [m/min]	Vorschub [mm/U]	Schnitttiefe [mm]
A010 Standardsorte für die allgemeinen Anwendungen	■ Aluminium/Al-Si Legierungen 4 % – 8 % Si	Drehen 900 – 3500 Fräsen 1000 – 5000	0.10 – 0.40 0.10 – 0.30	0.10 – 4.00 0.10 – 3.00
	■ Magnesiumlegierungen	Drehen/Fräsen 800 – 4000	0.10 – 0.50	0.10 – 4.00
	■ Kupferlegierungen (Messing, Bronze, Kupfer)	Drehen/Fräsen 400 – 1260	0.03 – 0.30	0.05 – 2.00
	■ Hartmetall <16 % Co ungesintert	Drehen 30 – 100	0.10 – 0.40	0.20 – 1.00
	■ Hartmetall <16 % Co gesintert	Drehen 20 – 40	0.10 – 0.25	0.10 – 0.50
	■ Keramik ungesintert	Drehen 70 – 100	0.10 – 0.40	0.20 – 1.00
	■ Keramik gesintert	Drehen 50 – 80	0.10 – 0.25	0.10 – 0.50
	■ Grafit/Kunstkohle	Drehen/Fräsen 300 – 2000	0.05 – 0.30	0.10 – 3.00
A020 Allgemein für stark unterbrochenen Schnitt und Schrappanwendungen	■ Aluminium/Al-Si Legierungen 4 % – 8 % Si	Drehen 900 – 3500	0.10 – 0.40	0.10 – 4.00
	■ Aluminium/Al-Si Legierungen 9 % – 14 % Si	Drehen 600 – 2400 Fräsen 700 – 3000	0.10 – 0.40 0.10 – 0.30	0.10 – 4.00 0.10 – 3.00
	■ Aluminium/Al-Si Legierungen >13 % Si	Drehen 300 – 700 Fräsen 400 – 900	0.10 – 0.40 0.10 – 0.30	0.10 – 4.00 0.10 – 3.00
	■ Metal Matrix Composites MMCs A1/10 % – 20 % SiC	Drehen/Fräsen 300 – 600	0.10 – 0.40	0.20 – 1.50
	■ Hartmetall <16 % Co ungesintert	Drehen 30 – 100	0.10 – 0.40	0.20 – 1.00
	■ Hartmetall <16 % Co gesintert	Drehen 20 – 40	0.10 – 0.25	0.10 – 0.50
	■ Keramik ungesintert	Drehen 70 – 100	0.10 – 0.40	0.20 – 1.00
	■ Keramik gesintert	Drehen 50 – 80	0.10 – 0.25	0.10 – 0.50
A030 Allgemein für feine Oberflächengüten	■ Magnesiumlegierungen	Drehen/Fräsen 800 – 4000	0.10 – 0.50	0.10 – 4.00
	■ Aluminium-Knetlegierungen ohne Si	Drehen 900 – 3500 Fräsen 1000 – 5000	0.10 – 0.40 0.10 – 0.30	0.10 – 4.00 0.10 – 3.00
	■ Kupferlegierungen (Messing, Bronze, Kupfer)	Drehen/Fräsen 400 – 1260	0.03 – 0.30	0.05 – 2.00
	■ Platin/Gold	Drehen 100 – 400 Fräsen 100 – 800	0.05 – 0.20 0.10 – 0.30	0.05 – 2.00 0.05 – 2.00
A040 Allgemein für verschleissintensive Anwendungen	■ Aluminium/Al-Si Legierungen >13 % Si	Drehen 300 – 700	0.10 – 0.40	0.10 – 4.00
	■ Allgemein für verschleissintensive Anwendungen	Drehen/Fräsen 300 – 600	0.10 – 0.40	0.20 – 1.50
	■ Kupferlegierungen (Messing, Bronze, Kupfer)	Drehen 400 – 1200	0.05 – 0.30	0.20 – 1.50
	■ Hartmetall <16 % Co ungesintert	Drehen 100 - 200	0.10 – 0.40	0.10 – 1.00
	■ Hartmetall <16 % Co gesintert	Drehen 20 – 40	0.10 – 0.25	0.10 – 1.00
A041 Allgemein für verschleissintensivste Anwendungen	■ GFK/Grafit	Drehen/Fräsen 300 - 1000	0.10 – 0.40	0.10 – 3.00
	■ Aluminium/Al-Si Legierungen >13 % Si	Drehen 300 – 700	0.10 – 0.40	0.10 – 4.00
	■ Metal Matrix Composites MMCs A1/10 % – 30 % SiC	Drehen/Fräsen 300 – 600	0.10 – 0.40	0.20 – 1.50
	■ Kupferlegierungen (Messing, Bronze, Kupfer)	Drehen 400 – 1200	0.05 – 0.30	0.20 – 1.50
	■ Hartmetall <16 % Co ungesintert	Drehen 100 - 200	0.10 – 0.40	0.10 – 1.00
■ Hartmetall <16 % Co gesintert	Drehen 20 – 40	0.10 – 0.25	0.10 – 1.00	
■ GFK/Grafit	Drehen/Fräsen 300 - 1000	0.10 – 0.40	0.10 – 3.00	



CVD-Diamant-Schneidwerkstoffe

Wichtige Hinweise für den Einsatz von CVD-Diamant-Schneidwerkstoffen

- Schneiden aufgrund von Ausbruchgefahr nicht mechanisch vermessen
- Für unterbrochenen Schnitt Schnittwerte ca. halbieren
- Intensive Kühlung mit leichter Bohremulsion verbessert die Schnittleistung erheblich
- Bei den meisten Anwendungen ist mit scharf ausgebildeten Schneidkanten zu arbeiten. Bei stark unterbrochenem Schnitt und bei Schruppanwendungen empfiehlt sich eine Schneidkantenverrundung von 0.025 mm zur Verhinderung von Schneidkantenausbruch
- Für einen Grossteil des Anwendungsspektrums kann ein neutraler oder leicht positiver Spanwinkel ($5^{\circ} - 8^{\circ}$) mit einem Freiwinkel ($10^{\circ} - 13^{\circ}$) verwendet werden
- Ein positiver Spanwinkel von $10^{\circ} - 15^{\circ}$ minimiert die Gratbildung bei weichen, duktilen Werkstoffen und optimiert den Spanablauf
- Verwenden Sie einen negativen Spanwinkel von $3^{\circ} - 5^{\circ}$ zur Zerspanung von spröden oder harten Werkstoffen wie gesintertem Hartmetall oder keramischen Werkstoffen

Sortimentsübersicht und Schnittdatenempfehlung

Sorte	Hauptanwendung	Schnittgeschwindigkeit V [m/min]	Vorschub [mm/U]	Schnitttiefe [mm]
A060 Allgemein bei erhöhtem Verschleiss	■ Aluminium/Al-Si Legierungen >13 % Si	Drehen 300 – 700	0.10 – 0.40	0.10 – 4.00
	■ Metal Matrix Composites MMCs A1/10 % – 30 % SiC	Drehen/Fräsen 300 – 600	0.10 – 0.40	0.20 – 1.50
	■ Kupferlegierungen (Messing, Bronze, Kupfer)	Drehen/Fräsen 400 – 1200	0.05 – 0.30	0.20 – 1.50
	■ GFK/Grafit	Drehen/Fräsen 300 – 1000	0.10 – 0.40	0.10 – 3.00
	■ Thermoplast mit Kohlefaser, Teflon und Glas (bis ca. 60 %)	Drehen/Fräsen 300 – 1000	0.10 – 0.40	0.10 – 3.00
	■ Wolfram	Drehen 20 - 70	0.10 – 0.30	0.10 – 0.30

MKD-Schneidwerkstoffe

Wichtige Hinweise für den Einsatz von MKD-Schneidwerkstoffen

- Schneiden aufgrund von Ausbruchgefahr nicht mechanisch vermessen
- Ein positiver Spanwinkel von $10^{\circ} - 15^{\circ}$ minimiert die Gratbildung bei weichen, duktilen Werkstoffen und optimiert den Spanablauf

Sortimentsübersicht und Schnittdatenempfehlung

Sorte	Hauptanwendung	Schnittgeschwindigkeit V [m/min]	Vorschub [mm/U]	Schnitttiefe [mm]
A070 Allgemein für Hochglanzbearbeitungen und feinste Oberflächengüten	■ Alu-Legierung bis 6 % SiC	150 – 250	0.04 – 0.10	0.01 – 2.00
	■ Kupfer Zink, Messing	600	0.01 – 0.40	0.01 – 1.00
	■ Gold, Silber	600	0.01 – 0.40	0.01 – 0.30
	■ Kunststoffe, Acrylglas	1500	0.10 – 0.80	0.01 – 0.30

Naturdiamant-Schneidwerkstoffe

Wichtige Hinweise für den Einsatz von Naturdiamant-Schneidwerkstoffen

- Schneiden aufgrund von Ausbruchgefahr nicht mechanisch vermessen
- Ein positiver Spanwinkel von $10^{\circ} - 15^{\circ}$ minimiert die Gratbildung bei weichen, duktilen Werkstoffen und optimiert den Spanablauf

Sortimentsübersicht und Schnittdatenempfehlung

Sorte	Hauptanwendung	Schnittgeschwindigkeit V [m/min]	Vorschub [mm/U]	Schnitttiefe [mm]
A080 Allgemein für Hochglanzbearbeitungen und feinste Oberflächengüten	■ Alu-Legierung bis 6 % SiC	150 – 250	0.04 – 0.10	0.01 – 2.00
	■ Kupfer Zink, Messing	600	0.01 – 0.40	0.01 – 1.00
	■ Gold, Silber	600	0.01 – 0.40	0.01 – 0.30
	■ Kunststoffe, Acrylglas	1500	0.10 – 0.80	0.01 – 0.30



Wendeschneidplatten ISO-Code

Form	Freiwinkel	Toleranz	Befestigung und/oder Spanbrecher	Eckenradius																																																																																																																																			
H Sechskant	<table border="1"> <tr><th>Standard Freiwinkel</th></tr> <tr><td>A 3°</td></tr> <tr><td>B 5°</td></tr> <tr><td>C 7°</td></tr> <tr><td>D 15°</td></tr> <tr><td>E 20°</td></tr> <tr><td>F 25°</td></tr> <tr><td>G 30°</td></tr> <tr><td>N 0°</td></tr> <tr><td>P 11°</td></tr> <tr><td>O weitere Freiwinkel</td></tr> </table>	Standard Freiwinkel	A 3°	B 5°	C 7°	D 15°	E 20°	F 25°	G 30°	N 0°	P 11°	O weitere Freiwinkel	<table border="1"> <tr><th>Toleranz ohne Radius m [mm]</th></tr> <tr><td>A ±0.005</td></tr> <tr><td>F ±0.005</td></tr> <tr><td>C ±0.013</td></tr> <tr><td>H ±0.013</td></tr> <tr><td>E ±0.025</td></tr> <tr><td>G ±0.025</td></tr> <tr><td>J ±0.005</td></tr> <tr><td>K¹⁾ ±0.013</td></tr> <tr><td>L¹⁾ ±0.025</td></tr> <tr><td>M¹⁾ ±0.08~±0.18</td></tr> <tr><td>N¹⁾ ±0.08~±0.18</td></tr> <tr><td>U¹⁾ ±0.13~±0.38</td></tr> </table>	Toleranz ohne Radius m [mm]	A ±0.005	F ±0.005	C ±0.013	H ±0.013	E ±0.025	G ±0.025	J ±0.005	K ¹⁾ ±0.013	L ¹⁾ ±0.025	M ¹⁾ ±0.08~±0.18	N ¹⁾ ±0.08~±0.18	U ¹⁾ ±0.13~±0.38	<table border="1"> <tr><th>Inkreibstoleranz Ød [mm]</th></tr> <tr><td>±0.025</td></tr> <tr><td>±0.013</td></tr> <tr><td>±0.025</td></tr> <tr><td>±0.013</td></tr> <tr><td>±0.025</td></tr> <tr><td>±0.025</td></tr> <tr><td>±0.05~±0.13</td></tr> <tr><td>±0.05~±0.13</td></tr> <tr><td>±0.05~±0.13</td></tr> <tr><td>±0.05~±0.13</td></tr> <tr><td>±0.08~±0.13</td></tr> <tr><td>±0.08~±0.13</td></tr> <tr><td>±0.08~±0.13</td></tr> </table>	Inkreibstoleranz Ød [mm]	±0.025	±0.013	±0.025	±0.013	±0.025	±0.025	±0.05~±0.13	±0.05~±0.13	±0.05~±0.13	±0.05~±0.13	±0.08~±0.13	±0.08~±0.13	±0.08~±0.13	<table border="1"> <tr><th>Dickentoleranz s [mm]</th></tr> <tr><td>±0.025</td></tr> <tr><td>±0.025</td></tr> <tr><td>±0.025</td></tr> <tr><td>±0.025</td></tr> <tr><td>±0.13</td></tr> <tr><td>±0.025</td></tr> <tr><td>±0.025</td></tr> <tr><td>±0.13</td></tr> <tr><td>±0.025</td></tr> <tr><td>±0.13</td></tr> <tr><td>±0.13</td></tr> </table>	Dickentoleranz s [mm]	±0.025	±0.025	±0.025	±0.025	±0.13	±0.025	±0.025	±0.13	±0.025	±0.13	±0.13	<table border="1"> <tr><th>Loch</th></tr> <tr><td>W mit Loch</td></tr> <tr><td>T mit Loch</td></tr> <tr><td>Q mit Loch</td></tr> <tr><td>U mit Loch</td></tr> <tr><td>B mit Loch</td></tr> <tr><td>H mit Loch</td></tr> <tr><td>C mit Loch</td></tr> <tr><td>J mit Loch</td></tr> <tr><td>A mit Loch</td></tr> <tr><td>M mit Loch</td></tr> <tr><td>G mit Loch</td></tr> <tr><td>N ohne Loch</td></tr> <tr><td>R ohne Loch</td></tr> <tr><td>F ohne Loch</td></tr> <tr><td>X -</td></tr> </table>	Loch	W mit Loch	T mit Loch	Q mit Loch	U mit Loch	B mit Loch	H mit Loch	C mit Loch	J mit Loch	A mit Loch	M mit Loch	G mit Loch	N ohne Loch	R ohne Loch	F ohne Loch	X -	<table border="1"> <tr><th>Lochkonfiguration</th></tr> <tr><td>Zylindrisches Loch + Senkung (40°~60°)</td></tr> <tr><td>Zylindrisches Loch + Senkung (40°~60°)</td></tr> <tr><td>Zylindrisches Loch + Senkung (70°~90°)</td></tr> <tr><td>Zylindrisches Loch + Senkung (70°~90°)</td></tr> <tr><td>Zylindrisches Loch</td></tr> <tr><td>Zylindrisches Loch</td></tr> <tr><td>Zylindrisches Loch</td></tr> <tr><td>Zylindrisches Loch</td></tr> <tr><td>Zylindrisches Loch</td></tr> <tr><td>Zylindrisches Loch</td></tr> <tr><td>Zylindrisches Loch</td></tr> <tr><td>-</td></tr> <tr><td>-</td></tr> <tr><td>-</td></tr> <tr><td>-</td></tr> </table>	Lochkonfiguration	Zylindrisches Loch + Senkung (40°~60°)	Zylindrisches Loch + Senkung (40°~60°)	Zylindrisches Loch + Senkung (70°~90°)	Zylindrisches Loch + Senkung (70°~90°)	Zylindrisches Loch	Zylindrisches Loch	Zylindrisches Loch	Zylindrisches Loch	Zylindrisches Loch	Zylindrisches Loch	Zylindrisches Loch	-	-	-	-	<table border="1"> <tr><th>Spanbrecher</th></tr> <tr><td>ohne</td></tr> <tr><td>einseitig</td></tr> <tr><td>ohne</td></tr> <tr><td>doppel-seitig</td></tr> <tr><td>ohne</td></tr> <tr><td>einseitig</td></tr> <tr><td>ohne</td></tr> <tr><td>doppel-seitig</td></tr> <tr><td>ohne</td></tr> <tr><td>einseitig</td></tr> <tr><td>einseitig</td></tr> <tr><td>doppel-seitig</td></tr> <tr><td>ohne</td></tr> <tr><td>einseitig</td></tr> <tr><td>doppel-seitig</td></tr> <tr><td>-</td></tr> <tr><td>-</td></tr> <tr><td>-</td></tr> <tr><td>spezielles Design</td></tr> </table>	Spanbrecher	ohne	einseitig	ohne	doppel-seitig	ohne	einseitig	ohne	doppel-seitig	ohne	einseitig	einseitig	doppel-seitig	ohne	einseitig	doppel-seitig	-	-	-	spezielles Design	<table border="1"> <tr><th>Plattentyp</th></tr> <tr><td>00</td></tr> <tr><td>002</td></tr> <tr><td>005</td></tr> <tr><td>010</td></tr> <tr><td>015</td></tr> <tr><td>020</td></tr> <tr><td>040</td></tr> <tr><td>050</td></tr> <tr><td>080</td></tr> <tr><td>100</td></tr> <tr><td>120</td></tr> </table>	Plattentyp	00	002	005	010	015	020	040	050	080	100	120	<table border="1"> <tr><th>Eckradius [mm]</th></tr> <tr><td>ohne Radius</td></tr> <tr><td>0.02</td></tr> <tr><td>0.05</td></tr> <tr><td>0.10</td></tr> <tr><td>0.15</td></tr> <tr><td>0.20</td></tr> <tr><td>0.40</td></tr> <tr><td>0.50</td></tr> <tr><td>0.80</td></tr> <tr><td>1.00</td></tr> <tr><td>1.20</td></tr> </table>	Eckradius [mm]	ohne Radius	0.02	0.05	0.10	0.15	0.20	0.40	0.50	0.80	1.00	1.20
Standard Freiwinkel																																																																																																																																							
A 3°																																																																																																																																							
B 5°																																																																																																																																							
C 7°																																																																																																																																							
D 15°																																																																																																																																							
E 20°																																																																																																																																							
F 25°																																																																																																																																							
G 30°																																																																																																																																							
N 0°																																																																																																																																							
P 11°																																																																																																																																							
O weitere Freiwinkel																																																																																																																																							
Toleranz ohne Radius m [mm]																																																																																																																																							
A ±0.005																																																																																																																																							
F ±0.005																																																																																																																																							
C ±0.013																																																																																																																																							
H ±0.013																																																																																																																																							
E ±0.025																																																																																																																																							
G ±0.025																																																																																																																																							
J ±0.005																																																																																																																																							
K ¹⁾ ±0.013																																																																																																																																							
L ¹⁾ ±0.025																																																																																																																																							
M ¹⁾ ±0.08~±0.18																																																																																																																																							
N ¹⁾ ±0.08~±0.18																																																																																																																																							
U ¹⁾ ±0.13~±0.38																																																																																																																																							
Inkreibstoleranz Ød [mm]																																																																																																																																							
±0.025																																																																																																																																							
±0.013																																																																																																																																							
±0.025																																																																																																																																							
±0.013																																																																																																																																							
±0.025																																																																																																																																							
±0.025																																																																																																																																							
±0.05~±0.13																																																																																																																																							
±0.05~±0.13																																																																																																																																							
±0.05~±0.13																																																																																																																																							
±0.05~±0.13																																																																																																																																							
±0.08~±0.13																																																																																																																																							
±0.08~±0.13																																																																																																																																							
±0.08~±0.13																																																																																																																																							
Dickentoleranz s [mm]																																																																																																																																							
±0.025																																																																																																																																							
±0.025																																																																																																																																							
±0.025																																																																																																																																							
±0.025																																																																																																																																							
±0.13																																																																																																																																							
±0.025																																																																																																																																							
±0.025																																																																																																																																							
±0.13																																																																																																																																							
±0.025																																																																																																																																							
±0.13																																																																																																																																							
±0.13																																																																																																																																							
Loch																																																																																																																																							
W mit Loch																																																																																																																																							
T mit Loch																																																																																																																																							
Q mit Loch																																																																																																																																							
U mit Loch																																																																																																																																							
B mit Loch																																																																																																																																							
H mit Loch																																																																																																																																							
C mit Loch																																																																																																																																							
J mit Loch																																																																																																																																							
A mit Loch																																																																																																																																							
M mit Loch																																																																																																																																							
G mit Loch																																																																																																																																							
N ohne Loch																																																																																																																																							
R ohne Loch																																																																																																																																							
F ohne Loch																																																																																																																																							
X -																																																																																																																																							
Lochkonfiguration																																																																																																																																							
Zylindrisches Loch + Senkung (40°~60°)																																																																																																																																							
Zylindrisches Loch + Senkung (40°~60°)																																																																																																																																							
Zylindrisches Loch + Senkung (70°~90°)																																																																																																																																							
Zylindrisches Loch + Senkung (70°~90°)																																																																																																																																							
Zylindrisches Loch																																																																																																																																							
Zylindrisches Loch																																																																																																																																							
Zylindrisches Loch																																																																																																																																							
Zylindrisches Loch																																																																																																																																							
Zylindrisches Loch																																																																																																																																							
Zylindrisches Loch																																																																																																																																							
Zylindrisches Loch																																																																																																																																							
-																																																																																																																																							
-																																																																																																																																							
-																																																																																																																																							
-																																																																																																																																							
Spanbrecher																																																																																																																																							
ohne																																																																																																																																							
einseitig																																																																																																																																							
ohne																																																																																																																																							
doppel-seitig																																																																																																																																							
ohne																																																																																																																																							
einseitig																																																																																																																																							
ohne																																																																																																																																							
doppel-seitig																																																																																																																																							
ohne																																																																																																																																							
einseitig																																																																																																																																							
einseitig																																																																																																																																							
doppel-seitig																																																																																																																																							
ohne																																																																																																																																							
einseitig																																																																																																																																							
doppel-seitig																																																																																																																																							
-																																																																																																																																							
-																																																																																																																																							
-																																																																																																																																							
spezielles Design																																																																																																																																							
Plattentyp																																																																																																																																							
00																																																																																																																																							
002																																																																																																																																							
005																																																																																																																																							
010																																																																																																																																							
015																																																																																																																																							
020																																																																																																																																							
040																																																																																																																																							
050																																																																																																																																							
080																																																																																																																																							
100																																																																																																																																							
120																																																																																																																																							
Eckradius [mm]																																																																																																																																							
ohne Radius																																																																																																																																							
0.02																																																																																																																																							
0.05																																																																																																																																							
0.10																																																																																																																																							
0.15																																																																																																																																							
0.20																																																																																																																																							
0.40																																																																																																																																							
0.50																																																																																																																																							
0.80																																																																																																																																							
1.00																																																																																																																																							
1.20																																																																																																																																							

Drehen: **C** **N** **M** **G** **12** **04** **08** **T** **B010**

Fräsen: **S** **E** **K** **N** **12** **03** **AF** **T** **B010**

Wendeschneidplattengröße							
Inkreis [mm]	R	W	G	D	C	S	T
3.97		02			03	03	06
6.00	06						
6.35		04	11		07	06	11
7.94		05			09	08	13
8.00	08						
9.525	09	06	16		11	09	16
10.00	10						
12.00	12						
12.70	12	08	19		15	12	22
15.875		10			19	16	27
16.00	16						
19.05	19	13			23	19	33
20.00	20						
22.225					27	22	38
25.00	25						
25.40	25				31	25	44
31.75	31				38	32	55
32.00	32						

Stärke	
Metrisch	Stärke [mm]
01	1.59
02	2.38
T2	2.78
03	3.18
T3	3.97
04	4.76
06	6.35
07	7.94
09	9.52

Anstellwinkel	
	α
A	45°
E	75°
P	90°
Standardfreiwinkel der Breit-schlichtplanfase	
D	15°
E	20°
F	25°
N	0°
P	11°

Schneidkantenausführung		
F	scharfkantig	
E	verrundet	
T	gefast	
S	gefast und verrundet	

Herstellerangaben	
Code	Typ
Herstellerspezifische Angaben mit Ziffern und/oder Buchstaben	
Werkzeuge von WEISS AG	
A010	Diamant-Werkzeuge
AXXX	
B010	CBN-Werkzeuge
BXXX	

¹⁾ Generell gilt dasselbe für gesinterte WSP, zum Teil abhängig von der Größe



Klemmdrehhalter ISO-Code

C	C	V	A	F	K	S	B
M	D	W	B	G	L	T	C
P	S	R	D	H	N	V	D
S	T	G	E	J	Q	X	N
Klemmsystem	WSP-Form		Werkzeugtyp			WSP-Freiwinkel	

Klemmdrehhalter

P C L N R 25 25 M 16

Bearbeitungsrichtung	Schaftquerschnitt Höhe (h) und Breite (b)	Werkzeuglänge [mm]	Wendeschneidplattengröße																																																																																										
R	<table border="1"> <tr><td>08</td><td>8</td><td>25</td><td>25</td></tr> <tr><td>10</td><td>10</td><td>32</td><td>32</td></tr> <tr><td>12</td><td>12</td><td>40</td><td>40</td></tr> <tr><td>16</td><td>16</td><td>50</td><td>50</td></tr> <tr><td>20</td><td>20</td><td></td><td></td></tr> </table>	08	8	25	25	10	10	32	32	12	12	40	40	16	16	50	50	20	20			D 60 N 160	<table border="1"> <thead> <tr> <th>Inkreis [mm]</th> <th>T</th> <th>S</th> <th>R</th> <th>80° C</th> <th>55° D</th> <th>45° G</th> </tr> </thead> <tbody> <tr><td>4.76</td><td>08</td><td></td><td></td><td></td><td></td><td></td></tr> <tr><td>5.56</td><td>09</td><td></td><td></td><td></td><td></td><td></td></tr> <tr><td>6.35</td><td>11</td><td>06</td><td></td><td></td><td></td><td></td></tr> <tr><td>7.94</td><td>13</td><td>07</td><td></td><td></td><td></td><td></td></tr> <tr><td>9.525</td><td>16</td><td>09</td><td>09</td><td>11</td><td></td><td></td></tr> <tr><td>12.7</td><td>22</td><td>12</td><td>12</td><td>15</td><td></td><td></td></tr> <tr><td>15.875</td><td>27</td><td>15</td><td>16</td><td>19</td><td></td><td></td></tr> <tr><td>19.05</td><td>33</td><td>19</td><td>19</td><td>23</td><td></td><td></td></tr> <tr><td>25.4</td><td>44</td><td>25</td><td>25</td><td>31</td><td></td><td></td></tr> </tbody> </table>	Inkreis [mm]	T	S	R	80° C	55° D	45° G	4.76	08						5.56	09						6.35	11	06					7.94	13	07					9.525	16	09	09	11			12.7	22	12	12	15			15.875	27	15	16	19			19.05	33	19	19	23			25.4	44	25	25	31		
08		8	25	25																																																																																									
10		10	32	32																																																																																									
12		12	40	40																																																																																									
16		16	50	50																																																																																									
20	20																																																																																												
Inkreis [mm]	T	S	R	80° C	55° D	45° G																																																																																							
4.76	08																																																																																												
5.56	09																																																																																												
6.35	11	06																																																																																											
7.94	13	07																																																																																											
9.525	16	09	09	11																																																																																									
12.7	22	12	12	15																																																																																									
15.875	27	15	16	19																																																																																									
19.05	33	19	19	23																																																																																									
25.4	44	25	25	31																																																																																									
L	E 70 P 170																																																																																												
N	F 80 R 200																																																																																												
	H 100 S 250																																																																																												
	K 125 T 300																																																																																												
	M 150 U 350																																																																																												

Bohrstangen ISO-Code

A Halter mit innerer Kühlmittelzufuhr, Stahlschaft	<table border="1"> <thead> <tr><th>Werkzeugdurchmesser Ød [mm]</th></tr> </thead> <tbody> <tr><td>08</td><td>Ø8</td></tr> <tr><td>10</td><td>Ø10</td></tr> <tr><td>12</td><td>Ø12</td></tr> <tr><td>16</td><td>Ø16</td></tr> <tr><td>20</td><td>Ø20</td></tr> <tr><td>25</td><td>Ø25</td></tr> <tr><td>32</td><td>Ø32</td></tr> <tr><td>40</td><td>Ø40</td></tr> <tr><td>50</td><td>Ø50</td></tr> </tbody> </table>	Werkzeugdurchmesser Ød [mm]	08	Ø8	10	Ø10	12	Ø12	16	Ø16	20	Ø20	25	Ø25	32	Ø32	40	Ø40	50	Ø50	<table border="1"> <thead> <tr><th>Werkzeuglänge l1 [mm]</th></tr> </thead> <tbody> <tr><td>F</td><td>80</td></tr> <tr><td>H</td><td>100</td></tr> <tr><td>K</td><td>125</td></tr> <tr><td>M</td><td>150</td></tr> <tr><td>R</td><td>200</td></tr> <tr><td>S</td><td>250</td></tr> <tr><td>T</td><td>300</td></tr> <tr><td>U</td><td>350</td></tr> <tr><td>V</td><td>400</td></tr> <tr><td>X</td><td>Sonderlänge</td></tr> </tbody> </table>	Werkzeuglänge l1 [mm]	F	80	H	100	K	125	M	150	R	200	S	250	T	300	U	350	V	400	X	Sonderlänge	M
Werkzeugdurchmesser Ød [mm]																																											
08		Ø8																																									
10		Ø10																																									
12		Ø12																																									
16		Ø16																																									
20		Ø20																																									
25		Ø25																																									
32		Ø32																																									
40		Ø40																																									
50	Ø50																																										
Werkzeuglänge l1 [mm]																																											
F	80																																										
H	100																																										
K	125																																										
M	150																																										
R	200																																										
S	250																																										
T	300																																										
U	350																																										
V	400																																										
X	Sonderlänge																																										
C Hartmetallschaft			P																																								
E Halter mit innerer Kühlmittelzufuhr, Hartmetallschaft			S																																								
S Stahlschaft																																											
Schaftausführung	Werkzeugdurchmesser Ød [mm]	Werkzeuglänge l1 [mm]		Klemmsystem																																							

Bohrstangen

A 16 M S C L C R 09

WSP-Form	Werkzeug-Typ	WSP-Freiwinkel	Bearbeitungsrichtung	Wendeschneidplattengröße																																																															
C	F	C	R	<table border="1"> <thead> <tr> <th>Inkreis [mm]</th> <th>C</th> <th>D</th> <th>G</th> <th>S</th> <th>T</th> <th>W</th> </tr> </thead> <tbody> <tr><td>3.87</td><td></td><td></td><td></td><td></td><td></td><td>02</td></tr> <tr><td>4.76</td><td></td><td></td><td></td><td></td><td></td><td></td></tr> <tr><td>5.56</td><td></td><td></td><td></td><td>09</td><td></td><td>S3</td></tr> <tr><td>6.35</td><td>06</td><td>07</td><td></td><td>11</td><td>11</td><td>04</td></tr> <tr><td>9.525</td><td>09</td><td>11</td><td></td><td>09</td><td>16</td><td>16</td></tr> <tr><td>12.70</td><td>12</td><td>15</td><td></td><td>12</td><td>22</td><td>08</td></tr> <tr><td>15.875</td><td>16</td><td></td><td></td><td></td><td></td><td></td></tr> <tr><td>19.05</td><td>19</td><td></td><td></td><td>19</td><td></td><td></td></tr> </tbody> </table>	Inkreis [mm]	C	D	G	S	T	W	3.87						02	4.76							5.56				09		S3	6.35	06	07		11	11	04	9.525	09	11		09	16	16	12.70	12	15		12	22	08	15.875	16						19.05	19			19		
Inkreis [mm]	C	D	G		S	T	W																																																												
3.87							02																																																												
4.76																																																																			
5.56					09		S3																																																												
6.35	06	07			11	11	04																																																												
9.525	09	11			09	16	16																																																												
12.70	12	15			12	22	08																																																												
15.875	16																																																																		
19.05	19				19																																																														
D	K	D	L																																																																
G	L	E																																																																	
S	Q	N																																																																	
T	U	P																																																																	
V																																																																			
W																																																																			



Produktspektrum

ISO-Schneidplatten mit BORAPACT(CBN)-Schneiden, Anwendung Innen → Seite 1-11
ISO-Schneidplatten mit BORAPACT(CBN)-Schneiden, Anwendung Aussen → Seite 1-16

Vorteile im Überblick

- Drehen von gehärteten Teilen ist wirtschaftlicher als Schleifen
- Geeignet für höchste Ansprüche
- Ausgezeichnete Abriebfestigkeit
- Hohe Verschleissfestigkeit
- Hervorragende chemische Stabilität

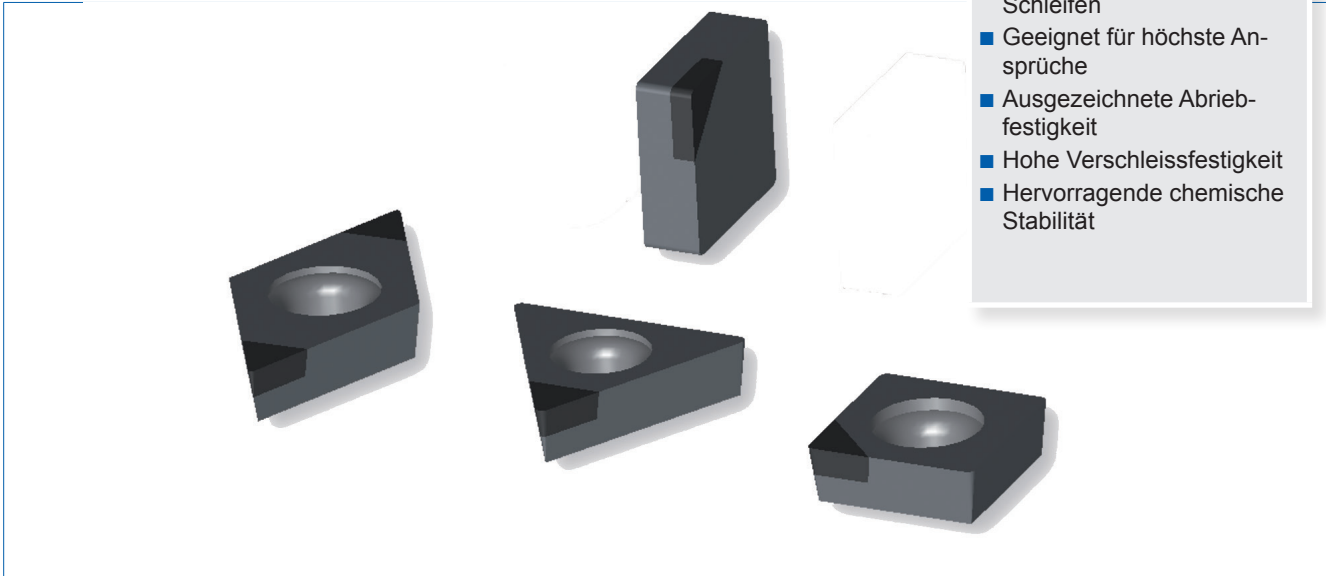

Produktmerkmale

- CBN-Rohlinge hartgelötet auf handelsübliche Hartmetallwendeplatten.
- Formen gemäss ISO oder nach Herstellerangaben.
- CBN-Sorte je nach Anwendung unterschiedlich.

Anwendungsbereiche

CBN-Schneidplatten erzielen hervorragende Ergebnisse beim Einsatz in perlitischem Grauguss, Einsatz- und Vergütungsstählen, gehärteten Wälzlagerstählen, pulvermetallurgisch hergestellten Eisenwerkstoffen, Aufspritzlegierungen und Superlegierungen auf Cr und Ni Basis.

Einsatzbedingungen

- Stabil gelagerte Maschine mit spielfreien Führungen.
- Kühlung notwendig!
Ausnahme: kleine Schnitttiefen von 0.1 – 0.2 mm
- Grundsätzliche Schnittgeschwindigkeit $v = 80 - 150$ m/min
- Schnitttiefe a max. 1 mm, bei unterbrochenem Schnitt 0.3 – 0.4 mm, aufgrund des geringen Schnittdruckes können Schnitttiefen von 0.005 mm gefahren werden.
- Vorschub s max. 0.1 mm/Umdrehung, bei unterbrochenem Schnitt 0.03 – 0.05 mm/Umdrehung.

Schneidkantenvorbereitung für BORAPACT(CBN)-Schneidplatten

- Grundsätzlich wird bei allen BORAPACT(CBN)-Schneidplatten eine Negativfase (T) angeschliffen.
- Zusätzlich wird für unterbrochenen Schnitt oder bei extremen Schruppoperationen eine zusätzliche Kantenverrundung von 0.025 mm empfohlen.

Werkstoff	BORAPACT(CBN)-Sorten B10, B040, B050, B075		BORAPACT(CBN)-Sorten B020, B060, B070
	Schruppen	Schlichten	Schlichten
Gehärtete Stähle	20° x 0.2 mm bis 0.5 mm	–	25° x 0.1 mm, zzgl. 0.01 mm verrundet
Aufspritzlegierungen	20° x 0.2 mm	20° x 0.2 mm	
Fe-Sinter-Werkstoffe	20° x 0.2 mm	20° x 0.2 mm	
Grauguss	20° x 0.2 mm	20° x 0.2 mm alternativ 0.025 mm verrundet	25° x 0.2 mm, zzgl. 0.01 mm verrundet
Hartgusslegierungen auf Ni/Co-Basis	20° x 0.2 mm bis 0.5 mm	20° x 0.2 bis 0.5 mm 0.012 mm verrundet	



ISO-Schneidplatten mit BORAPACT(CBN)-Schneiden

- Anwendung Innen
- Schneidenausführung **Mehrweg**

Typ CCMW

		Abmessungen				Typ
		l1 [mm]	l [mm]	s [mm]	r [mm]	
7°		3.7	6.45	2.38	0.2	CCMW 06 02 02 T B0..
		3.6	6.45	2.38	0.4	CCMW 06 02 04 T B0..
		3.5	6.45	2.38	0.8	CCMW 06 02 08 T B0..
		4.1	9.65	3.97	0.2	CCMW 09 T3 02 T B0..
		4.0	9.65	3.97	0.4	CCMW 09 T3 04 T B0..
		3.9	9.65	3.97	0.8	CCMW 09 T3 08 T B0..

Typ DCMW

		Abmessungen				Typ
		l1 [mm]	l [mm]	s [mm]	r [mm]	
7°		3.7	7.75	2.38	0.2	DCMW 07 02 02 T B0..
		3.5	7.75	2.38	0.4	DCMW 07 02 04 T B0..
		3.2	7.75	2.38	0.8	DCMW 07 02 08 T B0..
		3.8	11.6	3.97	0.2	DCMW 11 T3 02 T B0..
		3.5	11.6	3.97	0.4	DCMW 11 T3 04 T B0..
		3.2	11.6	3.97	0.8	DCMW 11 T3 08 T B0..

Typ TCMW

		Abmessungen				Typ
		l1 [mm]	l [mm]	s [mm]	r [mm]	
7°		3.7	9.63	2.38	0.4	TCMW 09 02 04 T B0..
		3.4	9.63	2.38	0.8	TCMW 09 02 08 T B0..
		4.0	11.0	2.38	0.2	TCMW 11 02 02 T B0..
		3.7	11.0	2.38	0.4	TCMW 11 02 04 T B0..
		3.4	11.0	2.38	0.8	TCMW 11 02 08 T B0..
		3.7	16.5	3.97	0.4	TCMW 16 T3 04 T B0..
		5.7	16.5	3.97	0.4	TCMW 16 T3 04 T B0..
		3.4	16.5	3.97	0.8	TCMW 16 T3 08 T B0..
		5.4	16.5	3.97	0.8	TCMW 16 T3 08 T B0..
		3.1	16.5	3.97	1.2	TCMW 16 T3 12 T B0..
		5.1	16.5	3.97	1.2	TCMW 16 T3 12 T B0..

Fortsetzung und Bestellinformationen siehe nächste Seite

Radiengröße lieferbar bis R 0.03mm
Fragen Sie uns an !!!!



ISO-Schneidplatten mit BORAPACT(CBN)-Schneiden

Anwendung Innen | Schneidenausführung Mehrweg

Typ TPMW

α	Abmessungen				Typ
	l1 [mm]	l [mm]	s [mm]	r [mm]	
11°	3.7	11.0	2.38	0.4	TPMW 11 02 04 T B0..
	3.4	11.0	2.38	0.8	TPMW 11 02 08 T B0..
	3.1	11.0	2.38	1.2	TPMW 11 02 12 T B0..

Typ TPUN

α	Abmessungen				Typ
	l1 [mm]	l [mm]	s [mm]	r [mm]	
11°	3.7	9.63	2.38	0.4	TPUN 09 02 04 T B0..
	3.4	9.63	2.38	0.8	TPUN 09 02 08 T B0..
	3.7	11.0	3.18	0.4	TPUN 11 03 04 T B0..
	3.4	11.0	3.18	0.8	TPUN 11 03 08 T B0..
	3.1	11.0	3.18	1.2	TPUN 11 03 12 T B0..
	3.7	16.5	3.18	0.4	TPUN 16 03 04 T B0..
	3.4	16.5	3.18	0.8	TPUN 16 03 08 T B0..
	3.1	16.5	3.18	1.2	TPUN 16 03 12 T B0..

Typ VCMW

α	Abmessungen				Typ
	l1 [mm]	l [mm]	s [mm]	r [mm]	
7°	4.6	11.1	3.18	0.2	VCMW 11 03 02 T B0..
	4.2	11.1	3.18	0.4	VCMW 11 03 04 T B0..
	3.4	11.1	3.18	0.8	VCMW 11 03 08 T B0..
	6.4	16.6	4.76	0.2	VCMW 16 04 02 T B0..
	6.2	16.6	4.76	0.4	VCMW 16 04 04 T B0..
	5.4	16.6	4.76	0.8	VCMW 16 04 08 T B0..
	4.4	16.6	4.76	1.2	VCMW 16 04 12 T B0..

Bestellinformationen

Verfügbare Ausführungen

Bestell-Code	BORAPACT(CBN)						
	B010	B020	B040	B050	B060	B070	B080
Verfügbarkeit	✓	○	○	○	○	○	○
Weitere Infos	→ Seite 1-5						

✓ Auf Lager ○ Auf Anfrage, bitte Wunschtermin für die Lieferung angeben

Bestellbeispiel für:

Typ: CCMW 06 02 02 T B0..
Ausführung: B040

- CCMW 06 02 02 T B040
- l1 = 3.7 mm
- tt.mm.jj (Wunschtermin)

**Radiengröße lieferbar bis R 0.03mm
Fragen Sie uns an !!!!**



ISO-Schneidplatten mit BORAPACT(CBN)-Schneiden

- Anwendung Innen
- Schneidenausführung Einweg (E)

Typ CCMW

		Abmessungen				Typ
α	l1 [mm]	l [mm]	s [mm]	r [mm]		
7°	2.0	6.45	2.38	0.2	CCMW 06 02 02 T-E B0..	
	2.0	6.45	2.38	0.4	CCMW 06 02 04 T-E B0..	
	2.5	9.65	3.97	0.2	CCMW 09 T3 02 T-E B0..	
	2.5	9.65	3.97	0.4	CCMW 09 T3 04 T-E B0..	
	2.5	9.65	3.97	0.8	CCMW 09 T3 08 T-E B0..	

Typ DCMW

		Abmessungen				Typ
α	l1 [mm]	l [mm]	s [mm]	r [mm]		
7°	2.0	7.75	2.38	0.2	DCMW 07 02 02 T-E B0..	
	2.0	7.75	2.38	0.4	DCMW 07 02 04 T-E B0..	
	2.5	11.6	3.97	0.2	DCMW 11 T3 02 T-E B0..	
	2.5	11.6	3.97	0.4	DCMW 11 T3 04 T-E B0..	

Typ TPUN

		Abmessungen				Typ
α	l1 [mm]	l [mm]	s [mm]	r [mm]		
11°	2.5	16.5	3.18	0.4	TPUN 16 03 04 T-E B0..	
	2.5	16.5	3.18	0.8	TPUN 16 03 08 T-E B0..	

Typ VCMW

		Abmessungen				Typ
α	l1 [mm]	l [mm]	s [mm]	r [mm]		
7°	2.5	11.1	3.18	0.2	VCMW 11 03 02 T-E B0..	
	2.5	11.1	3.18	0.4	VCMW 11 03 04 T-E B0..	
	3.0	16.6	4.76	0.2	VCMW 16 04 02 T-E B0..	
	3.0	16.6	4.76	0.4	VCMW 16 04 04 T-E B0..	

Bestellinformationen

Verfügbare Ausführungen

Bestell-Code	BORAPACT(CBN)						
	B010	B020	B040	B050	B060	B070	B080
Verfügbarkeit	✓	○	○	○	○	○	○
Weitere Infos	→ Seite 1-5						

✓ Auf Lager ○ Auf Anfrage, bitte Wunschtermin für die Lieferung angeben

Bestellbeispiel für:

Typ: DCMW 07 02 02 T-E B0..
Ausführung: B020

- DCMW 07 02 02 T-E B020
- l1 = 2.0 mm
- tt.mm.jj (Wunschtermin)

Radiengrösse lieferbar bis R 0.03mm
Fragen Sie uns an !!!!



ISO-Schneidplatten mit BORAPACT(CBN)-Schneiden

Anwendung Innen | Schneidenausführung Einweg – Doppelseitig

ISO-Schneidplatten mit BORAPACT(CBN)-Schneiden

- Anwendung Innen
- Schneidenausführung **Einweg – Doppelseitig (2E)**

Typ CCMW

α	Abmessungen				Typ
	l1 [mm]	l [mm]	s [mm]	r [mm]	
7°	2.0	6.45	2.38	0.2	CCMW 06 02 02 T-2E B0..
	2.0	6.45	2.38	0.4	CCMW 06 02 04 T-2E B0..
	2.5	9.65	3.97	0.2	CCMW 09 T3 02 T-2E B0..
	2.5	9.65	3.97	0.4	CCMW 09 T3 04 T-2E B0..
	2.5	9.65	3.97	0.8	CCMW 09 T3 08 T-2E B0..

Typ DCMW

α	Abmessungen				Typ
	l1 [mm]	l [mm]	s [mm]	r [mm]	
7°	2.0	7.75	2.38	0.2	DCMW 07 02 02 T-2E B0..
	2.0	7.75	2.38	0.4	DCMW 07 02 04 T-2E B0..
	2.5	11.6	3.97	0.2	DCMW 11 T3 02 T-2E B0..
	2.5	11.6	3.97	0.4	DCMW 11 T3 04 T-2E B0..

Typ VCMW

α	Abmessungen				Typ
	l1 [mm]	l [mm]	s [mm]	r [mm]	
7°	2.5	11.1	3.18	0.2	VCMW 11 03 02 T-2E B0..
	2.5	11.1	3.18	0.4	VCMW 11 03 04 T-2E B0..
	3.0	16.6	4.76	0.2	VCMW 16 04 02 T-2E B0..
	3.0	16.6	4.76	0.4	VCMW 16 04 04 T-2E B0..

Bestellinformationen

Verfügbare Ausführungen

Bestell-Code	BORAPACT(CBN)						
	B010	B020	B040	B050	B060	B070	B080
Verfügbarkeit	✓	○	○	○	○	○	○
Weitere Info	→ Seite 1-5						

✓ Auf Lager ○ Auf Anfrage, bitte Wunschtermin für die Lieferung angeben

Bestellbeispiel für:

Typ: VCMW 11 03 02 T-2E B0..
Ausführung: B070

- VCMW 11 03 02 T-2E B070
- l1 = 2.5 mm
- tt.mm.jj (Wunschtermin)

Radiengröße lieferbar bis R 0.03mm
Fragen Sie uns an !!!!



ISO-Schneidplatten mit BORAPACT(CBN)-Schneiden

- Anwendung Innen
- Schneidenausführung **Vollbelag**

Typ TPUN

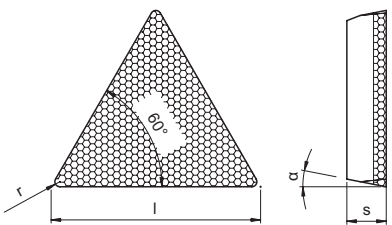
	Abmessungen				Typ
	α	l [mm]	s [mm]	r [mm]	
11°	Vollbelag	6.88	1.59	0.4	TPUN 06 01 04 T-V B0..
	Vollbelag	6.88	1.59	0.8	TPUN 06 01 08 T-V B0..
	Vollbelag	9.63	2.38	0.4	TPUN 09 02 04 T-V B0..
	Vollbelag	9.63	2.38	0.8	TPUN 09 02 08 T-V B0..

Bestellinformationen

Verfügbare Ausführungen

Bestell-Code	BORAPACT(CBN)		
	B010	B020	B040
Verfügbarkeit	✓	○	○
Weitere Info	→ Seite 1-5		

✓ Auf Lager ○ Auf Anfrage, bitte Wunschtermin für die Lieferung angeben

Bestellbeispiel für:

Typ: TPUN 06 01 04 T-V B0..
Ausführung: B040

- TPUN 06 01 04 T-V B040
- tt.mm.jj (Wunschtermin)

Radiengrösse lieferbar bis R 0.03mm
Fragen Sie uns an !!!!



ISO-Schneidplatten mit BORAPACT(CBN)-Schneiden

- Anwendung Aussen
- Schneidenausführung **Mehrweg**

Typ CCMW

		Abmessungen				Typ
α	l1 [mm]	l [mm]	s [mm]	r [mm]		
7°	4.0	12.9	4.76	0.4	CCMW 12 04 04 T B0..	
	5.8	12.9	4.76	0.4	CCMW 12 04 04 T B0..	
	3.9	12.9	4.76	0.8	CCMW 12 04 08 T B0..	
	5.7	12.9	4.76	0.8	CCMW 12 04 08 T B0..	

Typ CNMA

		Abmessungen				Typ
α	l1 [mm]	l [mm]	s [mm]	r [mm]		
0°	4.0	12.9	4.76	0.4	CNMA 12 04 04 T B0..	
	5.8	12.9	4.76	0.4	CNMA 12 04 04 T B0..	
	3.9	12.9	4.76	0.8	CNMA 12 04 08 T B0..	
	5.7	12.9	4.76	0.8	CNMA 12 04 08 T B0..	

Typ DNMA

		Abmessungen				Typ
α	l1 [mm]	l [mm]	s [mm]	r [mm]		
0°	5.4	15.5	4.76	0.4	DNMA 15 06 04 T B0..	
	5.1	15.5	4.76	0.8	DNMA 15 06 08 T B0..	
	4.7	15.5	4.76	1.2	DNMA 15 06 12 T B0..	

Typ SCMW

		Abmessungen				Typ
α	l1 [mm]	l [mm]	s [mm]	r [mm]		
7°	4.1	9.52	3.97	0.2	SCMW 09 T3 02 T B0..	
	4.1	9.52	3.97	0.4	SCMW 09 T3 04 T B0..	
	4.1	9.52	3.97	0.8	SCMW 09 T3 08 T B0..	
	4.1	12.7	4.76	0.2	SCMW 12 04 02 T B0..	
	6.1	12.7	4.76	0.2	SCMW 12 04 02 T B0..	
	4.1	12.7	4.76	0.4	SCMW 12 04 04 T B0..	
	6.1	12.7	4.76	0.4	SCMW 12 04 04 T B0..	
	4.1	12.7	4.76	0.8	SCMW 12 04 08 T B0..	
	6.1	12.7	4.76	0.8	SCMW 12 04 08 T B0..	

Fortsetzung siehe nächste Seite, Bestellinformationen → Seite 1-18

**Radiengröße lieferbar bis R 0.03mm
Fragen Sie uns an !!!!**



Typ SNMA

α	Abmessungen				Typ
	l1 [mm]	l [mm]	s [mm]	r [mm]	
0°	4.1	9.52	3.18	0.4	SNMA 09 03 04 T B0..
	4.1	9.52	3.18	0.8	SNMA 09 03 08 T B0..
	4.1	12.7	4.76	0.4	SNMA 12 04 04 T B0..
	6.1	12.7	4.76	0.4	SNMA 12 04 04 T B0..
	4.1	12.7	4.76	0.8	SNMA 12 04 08 T B0..
	6.1	12.7	4.76	0.8	SNMA 12 04 08 T B0..
	4.1	12.7	4.76	1.2	SNMA 12 04 12 T B0..
	6.1	12.7	4.76	1.2	SNMA 12 04 12 T B0..

Typ SNUN

α	Abmessungen				Typ
	l1 [mm]	l [mm]	s [mm]	r [mm]	
0°	4.1	9.52	3.18	0.4	SNUN 09 03 04 T B0..
	4.1	9.52	3.18	0.8	SNUN 09 03 08 T B0..
	4.1	12.7	3.18	0.4	SNUN 12 03 04 T B0..
	4.1	12.7	3.18	0.8	SNUN 12 03 08 T B0..
	6.1	12.7	4.76	0.4	SNUN 12 04 04 T B0..
	6.1	12.7	4.76	0.8	SNUN 12 04 08 T B0..
	6.1	12.7	4.76	1.2	SNUN 12 04 12 T B0..

Typ TNMA

α	Abmessungen				Typ
	l1 [mm]	l [mm]	s [mm]	r [mm]	
0°	3.7	11.0	3.18	0.4	TNMA 11 03 04 T B0..
	3.4	11.0	3.18	0.8	TNMA 11 03 08 T B0..
	3.1	11.0	3.18	1.2	TNMA 11 03 12 T B0..
	3.7	16.5	4.76	0.4	TNMA 16 04 04 T B0..
	5.7	16.5	4.76	0.4	TNMA 16 04 04 T B0..
	3.4	16.5	4.76	0.8	TNMA 16 04 08 T B0..
	5.4	16.5	4.76	0.8	TNMA 16 04 08 T B0..
	3.1	16.5	4.76	1.2	TNMA 16 04 12 T B0..
	5.1	16.5	4.76	1.2	TNMA 16 04 12 T B0..

Fortsetzung und Bestellinformationen siehe nächste Seite

Radiengrösse lieferbar bis R 0.03mm
Fragen Sie uns an !!!!



ISO-Schneidplatten mit BORAPACT(CBN)-Schneiden

Anwendung Aussen | Schneidenausführung Mehrweg

Typ TNUN

	Abmessungen				Typ	
	α	l1 [mm]	l [mm]	s [mm]		r [mm]
	0°	3.7	11.0	3.18	0.4	TNUN 11 03 04 T B0..
		3.4	11.0	3.18	0.8	TNUN 11 03 08 T B0..
		3.1	11.0	3.18	1.2	TNUN 11 03 12 T B0..
		3.7	16.5	3.18	0.4	TNUN 16 03 04 T B0..
		3.4	16.5	3.18	0.8	TNUN 16 03 08 T B0..
		3.1	16.5	3.18	1.2	TNUN 16 03 12 T B0..
		5.7	16.5	4.76	0.4	TNUN 16 04 04 T B0..
		5.4	16.5	4.76	0.8	TNUN 16 04 08 T B0..
		5.1	16.5	4.76	1.2	TNUN 16 04 12 T B0..

Typ VBMW

	Abmessungen				Typ	
	α	l1 [mm]	l [mm]	s [mm]		r [mm]
	5°	4.6	11.1	2.38	0.2	VBMW 11 02 02 T B0..
		4.2	11.1	2.38	0.4	VBMW 11 02 04 T B0..
		3.4	11.1	2.38	0.8	VBMW 11 02 08 T B0..
		6.4	16.6	4.76	0.2	VBMW 16 04 02 T B0..
		6.2	16.6	4.76	0.4	VBMW 16 04 04 T B0..
		5.4	16.6	4.76	0.8	VBMW 16 04 08 T B0..
		4.4	16.6	4.76	1.2	VBMW 16 04 12 T B0..

Typ VNMA

	Abmessungen				Typ	
	α	l1 [mm]	l [mm]	s [mm]		r [mm]
	0°	6.4	16.6	4.76	0.2	VNMA 16 04 02 T B0..
		6.0	16.6	4.76	0.4	VNMA 16 04 04 T B0..
		5.4	16.6	4.76	0.8	VNMA 16 04 08 T B0..

Bestellinformationen

Verfügbare Ausführungen

Bestell-Code	BORAPACT(CBN)						
	B010	B020	B040	B050	B060	B070	B080
Verfügbarkeit	✓	○	○	○	○	○	○
Weitere Infos	→ Seite 1-5						

✓ Auf Lager ○ Auf Anfrage, bitte Wunschtermin für die Lieferung angeben

Bestellbeispiel für:

Typ: CCMW 12 04 04 T B0..
Ausführung: B020

- CCMW 12 04 04 T B020
- l1 = 5.8 mm
- tt.mm.jj (Wunschtermin)

Radiengrösse lieferbar bis R 0.03mm

Fragen Sie uns an !!!!



ISO-Schneidplatten mit BORAPACT(CBN)-Schneiden

- Anwendung Aussen
- Schneidenausführung Einweg (E)

Typ CCMW

α	Abmessungen				Typ
	l1 [mm]	l [mm]	s [mm]	r [mm]	
7°	2.5	12.9	4.76	0.4	CCMW 12 04 04 T-E B0..
	2.5	12.9	4.76	0.8	CCMW 12 04 08 T-E B0..

Typ CNMA

α	Abmessungen				Typ
	l1 [mm]	l [mm]	s [mm]	r [mm]	
0°	2.5	12.9	4.76	0.4	CNMA 12 04 04 T-E B0..
	2.5	12.9	4.76	0.8	CNMA 12 04 08 T-E B0..

Typ SNUN

α	Abmessungen				Typ
	l1 [mm]	l [mm]	s [mm]	r [mm]	
0°	2.5	12.7	4.76	0.4	SNUN 12 04 04 T-E B0..
	2.5	12.7	4.76	0.8	SNUN 12 04 08 T-E B0..

Typ TNMA

α	Abmessungen				Typ
	l1 [mm]	l [mm]	s [mm]	r [mm]	
0°	2.5	16.5	4.76	0.1	TNMA 16 04 01 T-E B0..
	2.5	16.5	4.76	0.2	TNMA 16 04 02 T-E B0..
	2.5	16.5	4.76	0.4	TNMA 16 04 04 T-E B0..

Typ VBMW

α	Abmessungen				Typ
	l1 [mm]	l [mm]	s [mm]	r [mm]	
5°	2.5	11.1	2.38	0.2	VBMW 11 02 02 T-E B0..
	2.5	11.1	2.38	0.4	VBMW 11 02 04 T-E B0..
	3.0	16.6	4.76	0.2	VBMW 16 04 02 T-E B0..
	3.0	16.6	4.76	0.4	VBMW 16 04 04 T-E B0..
	3.0	16.6	4.76	0.8	VBMW 16 04 08 T-E B0..

Bestellinformationen

Verfügbare Ausführungen

Bestell-Code	BORAPACT(CBN)						
	B010	B020	B040	B050	B060	B070	B080
Verfügbarkeit	✓	○	○	○	○	○	○
Weitere Infos	→ Seite 1-5						

✓ Auf Lager ○ Auf Anfrage, bitte Wunschtermin für die Lieferung angeben

Bestellbeispiel für:

Typ: CNMA 12 04 04 T-E B0..
Ausführung: B070

- CNMA 12 04 04 T-E B070
- l1 = 2.5 mm
- tt.mm.jj (Wunschtermin)

Radiengröße lieferbar bis R 0.03mm

Fragen Sie uns an !!!!



ISO-Schneidplatten mit BORAPACT(CBN)-Schneiden

Anwendung Aussen | Schneidenausführung Einweg – Doppelseitig

ISO-Schneidplatten mit BORAPACT(CBN)-Schneiden

- Anwendung Aussen
- Schneidenausführung **Einweg – Doppelseitig (2E)**

Typ CCMW

	Abmessungen				Typ	
	α	l1 [mm]	l [mm]	s [mm]		r [mm]
	7°	2.5	12.9	4.76	0.4	CCMW 12 04 04 T-2E B0..
		2.5	12.9	4.76	0.8	CCMW 12 04 08 T-2E B0..

Typ CNMA

	Abmessungen				Typ	
	α	l1 [mm]	l [mm]	s [mm]		r [mm]
	0°	2.5	12.9	4.76	0.4	CNMA 12 04 04 T-2E B0..
		2.5	12.9	4.76	0.8	CNMA 12 04 08 T-2E B0..

Typ SNUN

	Abmessungen				Typ	
	α	l1 [mm]	l [mm]	s [mm]		r [mm]
	0°	2.5	12.7	4.76	0.4	SNUN 12 04 04 T-2E B0..
		2.5	12.7	4.76	0.8	SNUN 12 04 08 T-2E B0..

Typ VBMW

	Abmessungen				Typ	
	α	l1 [mm]	l [mm]	s [mm]		r [mm]
	5°	2.5	11.1	2.38	0.2	VBMW 11 02 02 T-2E B0..
		2.5	11.1	2.38	0.4	VBMW 11 02 04 T-2E B0..
		3.0	16.6	4.76	0.2	VBMW 16 04 02 T-2E B0..
		3.0	16.6	4.76	0.4	VBMW 16 04 04 T-2E B0..
		3.0	16.6	4.76	0.8	VBMW 16 04 08 T-2E B0..

Bestellinformationen

Verfügbare Ausführungen

Bestell-Code	BORAPACT(CBN)						
	B010	B020	B040	B050	B060	B070	B080
Verfügbarkeit	✓	○	○	○	○	○	○
Weitere Infos	→ Seite 1-5						

✓ Auf Lager ○ Auf Anfrage, bitte Wunschtermin für die Lieferung angeben

Bestellbeispiel für:

Typ: VBMW 11 02 02 T-2E B0..
Ausführung: B070

- VBMW 11 02 02 T-2E B070
- l1 = 2.5 mm
- tt.mm.jj (Wunschtermin)

**Radiengrösse lieferbar bis R 0.03mm
Fragen Sie uns an !!!!**



ISO-Schneidplatten mit BORAPACT(CBN)-Schneiden

- Anwendung Aussen
- Schneidenausführung **Vollbelag**

Typ RNUN

Abmessungen		Abmessungen		Typ	
		α	d [mm]		s [mm]
		0°	Vollbelag 9.5	3.18	RNUN 09 03 00 T-V B0..
			Vollbelag 12.7	3.18	RNUN 12 03 00 T-V B0..
			Vollbelag 12.7	4.76	RNUN 12 04 00 T-V B0..

Typ SNUN

Abmessungen		Abmessungen			Typ	
		α	l [mm]	s [mm]		r [mm]
		0°	Vollbelag 12.7	4.76	0.4	SNUN 12 04 04 T-V B0..
			Vollbelag 12.7	4.76	0.8	SNUN 12 04 08 T-V B0..
			Vollbelag 12.7	4.76	1.2	SNUN 12 04 12 T-V B0..

Typ TNUN

Abmessungen		Abmessungen			Typ	
		α	l [mm]	s [mm]		r [mm]
		0°	Vollbelag 11.0	3.18	0.4	TNUN 11 03 04 T-V B0..
			Vollbelag 11.0	3.18	0.8	TNUN 11 03 08 T-V B0..
			Vollbelag 11.0	3.18	1.2	TNUN 11 03 12 T-V B0..
			Vollbelag 16.5	3.18	0.4	TNUN 16 03 04 T-V B0..
			Vollbelag 16.5	3.18	0.8	TNUN 16 03 08 T-V B0..
			Vollbelag 16.5	3.18	1.2	TNUN 16 03 12 T-V B0..

Bestellinformationen

Verfügbare Ausführungen

	BORAPACT(CBN)		
	B010	B020	B040
Bestell-Code			
Verfügbarkeit	✓	○	○
Weitere Infos	→ Seite 1-5		

✓ Auf Lager ○ Auf Anfrage, bitte Wunschtermin für die Lieferung angeben

Bestellbeispiel für:

Typ: RNUN 09 03 00 T-V B0..
Ausführung: B020

- RNUN 09 03 00 T-V B020
- tt.mm.jj (Wunschtermin)

Radiengrösse lieferbar bis R 0.03mm
Fragen Sie uns an !!!!



ISO-Schneidplatten mit BORAPACT(CBN)-Schneiden

Anwendung Aussen | Schneidenausführung Massivplatte

ISO-Schneidplatten mit BORAPACT(CBN)-Schneiden

- Anwendung Aussen
- Schneidenausführung **Massivplatte**

Typ CNMN

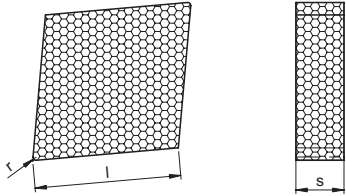
	Abmessungen				Typ	
	α		l [mm]	s [mm]		r [mm]
	0°	Massivplatte	9.52	3.18	0.4	CNMN 09 03 04 T B075
		Massivplatte	9.52	3.18	0.8	CNMN 09 03 08 T B075
		Massivplatte	12.7	3.18	0.4	CNMN 12 03 04 T B075
		Massivplatte	12.7	3.18	0.8	CNMN 12 03 08 T B075
		Massivplatte	12.7	3.18	1.2	CNMN 12 03 12 T B075

Typ RNMN

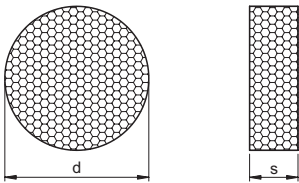
	Abmessungen				Typ	
	α		d [mm]	s [mm]		r [mm]
	0°	Massivplatte	9.52	3.18	–	RNMN 09 03 00 T B075
		Massivplatte	12.7	3.18	–	RNMN 12 03 00 T B075
		Massivplatte	12.7	4.76	–	RNMN 12 04 00 T B075

Typ SNMN

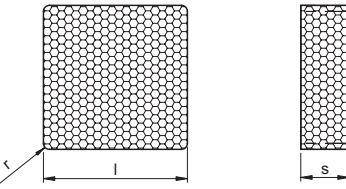
	Abmessungen				Typ	
	α		l [mm]	s [mm]		r [mm]
	0°	Massivplatte	9.52	3.18	0.4	SNMN 09 03 04 T B075
		Massivplatte	9.52	3.18	0.8	SNMN 09 03 08 T B075
		Massivplatte	12.7	3.18	0.4	SNMN 12 03 04 T B075
		Massivplatte	12.7	3.18	0.8	SNMN 12 03 08 T B075
		Massivplatte	12.7	3.18	1.2	SNMN 12 03 12 T B075

Typ TNMN

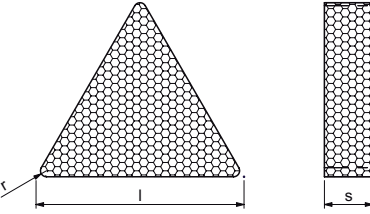
	Abmessungen				Typ	
	α		l [mm]	s [mm]		r [mm]
	0°	Massivplatte	11.0	3.18	0.4	TNMN 11 03 04 T B075
		Massivplatte	11.0	3.18	0.8	TNMN 11 03 08 T B075

Bestellinformationen

Verfügbare Ausführungen

	BORAPACT(CBN)
Bestell-Code	B075
Verfügbarkeit	○
Weitere Infos	→ Seite 1-5

✓ Auf Lager ○ Auf Anfrage, bitte Wunschtermin für die Lieferung angeben

Bestellbeispiel für:

Typ: SNMN 09 03 04 T B075
Ausführung: B075

- SNMN 09 03 04 T B075
- tt.mm.jj (Wunschtermin)

Radiengrösse lieferbar bis R 0.03mm
Fragen Sie uns an !!!!





Produktspektrum

Beschichtete ISO-Schneidplatten mit BORAPACT(CBN)-Schneiden → Seite 1-26

Vorteile im Überblick

- Hohe Verschleissfestigkeit
- Aussergewöhnliche Schneidkantenstabilität
- Vergrößerter Einsatzbereich
- Ausgezeichnete Oberflächengüte
- Weniger Aufbauschneiden
- Geringerer Freiflächenverschleiss

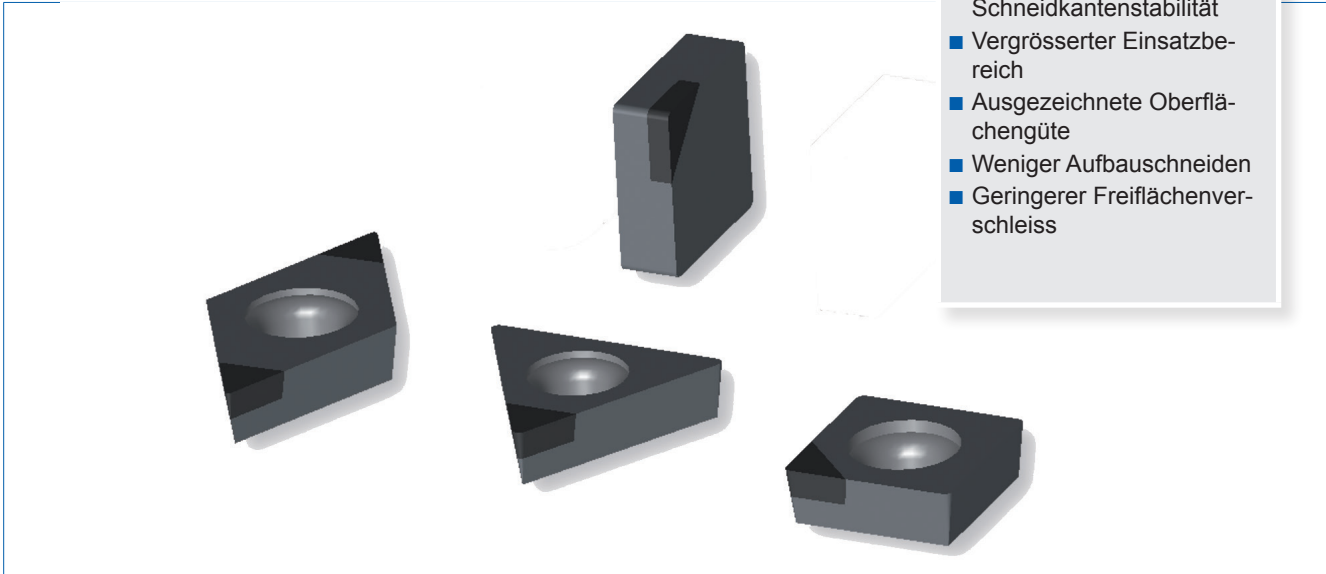

Produktmerkmale

- CBN-Rohlinge hartgelötet auf handelsübliche Hartmetallwendeplatten.
- Verwendung von speziellen CBN-Sorten
- Spezielle Beschichtungen

Anwendungsbereiche

Beschichtete CBN-Schneidplatten erzielen hervorragende Ergebnisse beim Einsatz in perlitischem Grauguss, Einsatz- und Vergütungsstählen, gehärteten Wälzlagerstählen, pulvermetallurgisch hergestellten Eisenwerkstoffen, Aufspritzlegierungen und Superlegierungen auf Cr und Ni Basis.

Einsatzbedingungen

- Stabil gelagerte Maschine mit spielfreien Führungen.
- Kühlung notwendig!
Ausnahme: kleine Schnitttiefen von 0.1 – 0.2 mm
- Grundsätzliche Schnittgeschwindigkeit $v = 80 - 150$ m/min
- Schnitttiefe a max. 1 mm, bei unterbrochenem Schnitt 0.3 – 0.4 mm, aufgrund des geringen Schnittdruckes können Schnitttiefen von 0.005 mm gefahren werden.
- Vorschub s max. 0.1 mm/Umdrehung, bei unterbrochenem Schnitt 0.03 – 0.05 mm/Umdrehung.



Anwendungsbereiche

Beschichtete BORAPACT(CBN)-Schneidplatten eignen sich für Voll- und leicht unterbrochene Schnitte bei hohen Schnittgeschwindigkeiten von $V_c = 60 - 300$ m/min.

Sorte	Anwendungsbereich	Merkmale
B010 C1	Von leicht bis normal unterbrochenem Schnitt. Geeignet zur Entfernung von Aufspritz- und Aufschweislegierungen.	Universalsorte mit dem grössten Einsatzbereich.
B050 C1	Kontinuierlicher bis hin zu stark unterbrochenem Schnitt. Bestens geeignet für die Bearbeitung von Gusseisen, pulvermetallurgischen Werkstoffen und Werkzeugstählen	Zähe Sorte für Anwendungen mit schweren Schnittunterbrechungen.
B060 C1	Einsatz in erster Linie für das Schlichten im kontinuierlichen Schnitt von gehärtetem Einsatz-, Vergütungs-, Werkzeug- und Wälzlagerstahl.	Geringe chemische Reaktivität und optimierte Wärmeleitfähigkeit. Erzielung von guten Oberflächengüten.
B070 C1	Einsatz im kontinuierlichen wie auch im moderat unterbrochenen Schnitt. Anwendung bei Einsatz-, Vergütungs- und legierten Stählen.	Die Kombination von hohem Verschleisswiderstand durch verbesserte Abriebfestigkeit, erhöhter chemischer Stabilität und guter Schlagfestigkeit ermöglicht ausgezeichnete Materialabtragsraten, gute Oberflächengüten und beste Werkzeugstandzeiten.

Empfohlene Schnittbedingungen

Sorte	Schnittgeschwindigkeit V [m/min]	Vorschub [mm/U]	Schnitttiefe [mm]
B010 C1	100 - 300	0.05 – 0.25	0.05 – 0.50
B050 C1	60 - 120	0.05 – 0.30	0.05 – 0.50
B060 C1	80 - 250	0.05 – 0.20	0.05 – 0.25
B070 C1	80 - 200	0.05 – 0.20	0.05 – 0.35

Einsatzbedingungen

- Schneiden nie mechanisch vermessen (Ausbruchgefahr)
- Kühlmittel beim Vollschnitt: trocken oder oder nass
- beim unterbrochenen Schnitt: trocken
- Möglichst hohe Schnittwerte anstreben um so die Reibung zu reduzieren und dadurch die Standzeit zu erhöhen



Beschichtete ISO-Schneidplatten mit BORAPACT(CBN)-Schneiden

Anwendung Innen | Schneidenausführung Einweg

Einweg-ISO-Schneidplatten mit BORAPACT (CBN)-Schneiden und Beschichtung C1

- Anwendung Innen
- Schneidenausführung **Einweg (E)**

Typ CCMW

α	Abmessungen				Typ
	l1 [mm]	l [mm]	s [mm]	r [mm]	
7°	2.0	6.45	2.38	0.2	CCGW 06 02 02 T-E-C1 B0..
	2.0	6.45	2.38	0.4	CCGW 06 02 04 T-E-C1 B0..
	2.0	6.45	2.38	0.4	CCGW 06 02 08 T-E-C1 B0..
	2.5	9.65	3.97	0.2	CCGW 09 T3 02 T-E-C1 B0..
	2.5	9.65	3.97	0.4	CCGW 09 T3 04 T-E-C1 B0..
	2.5	9.65	3.97	0.8	CCGW 09 T3 08 T-E-C1 B0..

Typ DCGW

α	Abmessungen				Typ
	l1 [mm]	l [mm]	s [mm]	r [mm]	
7°	2.0	7.75	2.38	0.2	DCGW 07 02 02 T-E-C1 B0..
	2.0	7.75	2.38	0.4	DCGW 07 02 04 T-E-C1 B0..
	2.0	7.75	2.38	0.8	DCGW 07 02 08 T-E-C1 B0..
	2.5	11.6	3.97	0.2	DCGW 11 T3 02 T-E-C1 B0..
	2.5	11.6	3.97	0.2	DCGW 11 T3 04 T-E-C1 B0..
	2.5	11.6	3.97	0.4	DCGW 11 T3 08 T-E-C1 B0..

Typ TCGW

α	Abmessungen				Typ
	l1 [mm]	l [mm]	s [mm]	r [mm]	
7°	2.5	9.63	3.18	0.4	TCGW 11 02 04 T-E-C1 B0..
	2.5	9.63	3.18	0.8	TCGW 11 02 08 T-E-C1 B0..

Typ VCMW

α	Abmessungen				Typ
	l1 [mm]	l [mm]	s [mm]	r [mm]	
7°	2.5	11.1	3.18	0.2	VCMW 11 03 02 T-E-C1 B0..
	2.5	11.1	3.18	0.4	VCMW 11 03 04 T-E-C1 B0..
	3.0	16.6	4.76	0.2	VCMW 16 04 02 T-E-C1 B0..
	3.0	16.6	4.76	0.4	VCMW 16 04 04 T-E-C1 B0..

Bestellinformationen

Verfügbare Ausführungen

Bestell-Code	BORAPACT(CBN)			
	B010-C1	B050-C1	B060-C1	B070-C1
Verfügbarkeit	✓	○	○	○
Weitere Infos	→ Seite 1-25			

✓ Auf Lager ○ Auf Anfrage, bitte Wunschtermin für die Lieferung angeben

Bestellbeispiel für:

Typ: DCGW 07 02 02 T-E-C1 B0..
Ausführung: B050

- DCMW 07 02 02 T-E-C1 B050
- l1 = 2.0 mm
- tt.mm.jj (Wunschtermin)

Radiengröße lieferbar bis R 0.03mm
Fragen Sie uns an !!!!



Einweg-ISO-Schneidplatten mit BORAPACT (CBN)-Schneiden und Beschichtung C1

- Anwendung Innen
- Schneidenausführung **Einweg**

Typ CNGA

α	Abmessungen				Typ
	l1 [mm]	l [mm]	s [mm]	r [mm]	
0°	2.5	12.9	4.76	0.4	CNGA 12 04 04 T-E-C1 B0..
	2.5	12.9	4.76	0.8	CNGA 12 04 08 T-E-C1 B0..

Typ SNGA

α	Abmessungen				Typ
	l1 [mm]	l [mm]	s [mm]	r [mm]	
0°	2.5	12.7	4.76	0.4	SNGA 12 04 04 T-E-C1 B0..
	2.5	12.7	4.76	0.8	SNGA 12 04 08 T-E-C1 B0..

Typ TNGA

α	Abmessungen				Typ
	l1 [mm]	l [mm]	s [mm]	r [mm]	
0°	2.5	16.5	4.76	0.2	TNGA 16 04 02 T-E-C1 B0..
	2.5	16.5	4.76	0.4	TNGA 16 04 04 T-E-C1 B0..
	2.5	16.5	4.76	0.8	TNGA 16 04 08 T-E-C1 B0..

Typ VBMW

α	Abmessungen				Typ
	l1 [mm]	l [mm]	s [mm]	r [mm]	
5°	2.5	11.1	3.18	0.2	VBMW 11 03 02 T-E-C1 B0..
	2.5	11.1	3.18	0.4	VBMW 11 03 04 T-E-C1 B0..
	3.0	16.6	4.76	0.2	VBMW 16 04 02 T-E-C1 B0..
	3.0	16.6	4.76	0.4	VBMW 16 04 04 T-E-C1 B0..
	3.0	16.6	4.76	0.8	VBMW 16 04 08 T-E-C1 B0..

Bestellinformationen

Verfügbare Ausführungen

Bestell-Code	BORAPACT(CBN)			
	B010-C1	B050-C1	B060-C1	B070-C1
Verfügbarkeit	✓	○	○	○
Weitere Infos	→ Seite 1-25			

✓ Auf Lager ○ Auf Anfrage, bitte Wunschtermin für die Lieferung angeben

Bestellbeispiel für:

Typ: DCGW 07 02 02 T-E-C1 B0..
Ausführung: B050

- DCGW 07 02 02 T-E-C1 B050
- l1 = 2.0 mm
- tt.mm.jj (Wunschtermin)

Radiengrösse lieferbar bis R 0.03mm
Fragen Sie uns an !!!!



Produktspektrum

ISO-Schneidplatten mit Diamant-Schneiden, Anwendung Innen
ISO-Schneidplatten mit Diamant-Schneiden, Anwendung Aussen

→ Seite 1-29
→ Seite 1-36

Vorteile im Überblick

- Engste Masstoleranzen und feinste Oberflächen
- Höchste Standzeiten
- Minimierte Ausschussraten
- Geringe oder keine Gratbildung

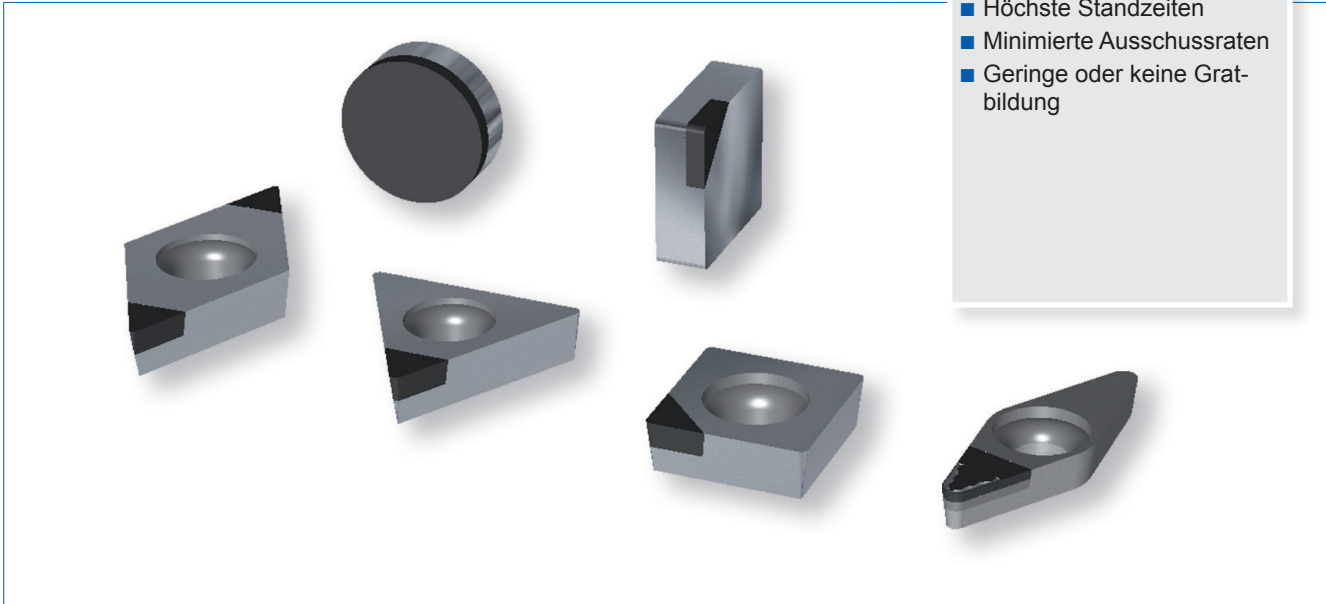

Produktmerkmale

- Diamant-Rohlinge hartgelötet oder vakuumgelötet auf handelsübliche Hartmetallwendeplatten.
- Je nach Schneidstoff enthalten die Diamanten weiche Bindemittel (PKD) oder keine (CVD-Diamant, MKD und Naturdiamant).
- Wahl der Diamantsorte je nach Anwendung.

Anwendungsbereiche

Werkzeuge mit Diamantschneiden erzielen hervorragende Ergebnisse im Bereich Standzeit, Oberflächengüten, Produktionszeiten und sind somit vor allem geeignet bei grossen Stückzahlen oder bei starkem Werkzeugverschleiss.

Durch die hohe Abriebfestigkeit ergeben sich sehr lange Nutzungszeiten der Werkzeuge und somit geringe Stillstandzeiten der Produktionsmaschinen.

PKD-Schneidplatten	CVD-Diamant-Schneidplatten	MKD-Schneidplatten	Naturdiamant-Schneidplatten
Al-Si-Legierungen bis 20 % Si	Al-Si-Legierungen ab 13 % Si	Alu-Legierungen bis 6 % Si	Alu-Legierungen bis 6 % Si
Keramik ungesintert und gesintert	MMCs	Kupfer	Kupfer
Kupferlegierungen	GFK/Grafit	Gold	Gold
GFK/CFK	Wolfram	Silber	Silber
Hartmetalle ungesintert und gesintert	Thermoplast mit Kohlefaser, Teflon mit hohem Glasanteil	Kunststoffe	Kunststoffe

Einsatzbedingungen

- Schneiden nie mechanisch vermessen (Ausbruchgefahr).
- Schneidplatten vor Schneidenbruch nachschleifen lassen.
- Für unterbrochenen Schnitt Schnittwerte ca. halbieren.
- Intensive Kühlung mit leichter Bohremulsion verbessert die Schnittleistung erheblich.
- Möglichst hohe Schnittwerte anstreben, um so die Reibung zu reduzieren und dadurch die Standzeit der Schneidplatte zu erhöhen.



ISO-Schneidplatten mit Diamant-Schneiden

- Anwendung Innen
- Schneidenausführung **Mehrweg**

Typ CCMW

		Abmessungen				Typ
		l1 [mm]	l [mm]	s [mm]	r [mm]	
7°	α	3.7	6.45	2.38	0.2	CCMW 06 02 02 F A0..
		3.6	6.45	2.38	0.4	CCMW 06 02 04 F A0..
		4.7	9.65	3.97	0.2	CCMW 09 T3 02 F A0..
		4.6	9.65	3.97	0.4	CCMW 09 T3 04 F A0..
		4.5	9.65	3.97	0.8	CCMW 09 T3 08 F A0..

Typ CPGW

		Abmessungen				Typ
		l1 [mm]	l [mm]	s [mm]	r [mm]	
11°	α	2.7	5.6	2.38	0.2	CPGW 05 02 02 F A0..
		2.6	5.6	2.38	0.4	CPGW 05 02 04 F A0..
		3.6	6.45	2.38	0.2	CPGW 06 02 02 F A0..
		3.5	6.45	2.38	0.4	CPGW 06 02 04 F A0..

Typ DCMW

		Abmessungen				Typ
		l1 [mm]	l [mm]	s [mm]	r [mm]	
7°	α	3.2	7.75	2.38	0.2	DCMW 07 02 02 F A0..
		3.0	7.75	2.38	0.4	DCMW 07 02 04 F A0..
		4.2	11.6	3.97	0.2	DCMW 11 T3 02 F A0..
		4.0	11.6	3.97	0.4	DCMW 11 T3 04 F A0..
		3.7	11.6	3.97	0.8	DCMW 11 T3 08 F A0..

Typ TCMW

		Abmessungen				Typ
		l1 [mm]	l [mm]	s [mm]	r [mm]	
7°	α	3.4	9.63	2.38	0.2	TCMW 09 02 02 F A0..
		3.2	9.63	2.38	0.4	TCMW 09 02 04 F A0..
		3.0	9.63	2.38	0.8	TCMW 09 02 08 F A0..
		3.4	11.0	2.38	0.2	TCMW 11 02 02 F A0..
		3.2	11.0	2.38	0.4	TCMW 11 02 04 F A0..
		3.0	11.0	2.38	0.8	TCMW 11 02 08 F A0..
		4.4	16.5	3.97	0.2	TCMW 16 T3 02 F A0..
		4.2	16.5	3.97	0.4	TCMW 16 T3 04 F A0..
		4.0	16.5	3.97	0.8	TCMW 16 T3 08 F A0..

Fortsetzung und Bestellinformationen siehe nächste Seite

**Radiengröße lieferbar bis R 0.03mm
Fragen Sie uns an !!!!**



ISO-Schneidplatten mit Diamant-Schneiden

Anwendung Innen | Schneidenausführung Mehrweg

Typ TPMW

	Abmessungen				Typ	
	α	l1 [mm]	l [mm]	s [mm]		r [mm]
11°		3.4	11.0	2.38	0.2	TPMW 11 02 02 F A0..
		3.2	11.0	2.38	0.4	TPMW 11 02 04 F A0..
		3.0	11.0	2.38	0.8	TPMW 11 02 08 F A0..

Typ TPUN

	Abmessungen				Typ	
	α	l1 [mm]	l [mm]	s [mm]		r [mm]
11°		3.4	11.0	3.18	0.2	TPUN 11 03 02 F A0..
		3.2	11.0	3.18	0.4	TPUN 11 03 04 F A0..
		3.0	11.0	3.18	0.8	TPUN 11 03 08 F A0..
		3.4	16.5	3.18	0.2	TPUN 16 03 02 F A0..
		6.5	16.5	3.18	0.2	TPUN 16 03 02 F A0..
		3.2	16.5	3.18	0.4	TPUN 16 03 04 F A0..
		6.3	16.5	3.18	0.4	TPUN 16 03 04 F A0..
		3.0	16.5	3.18	0.8	TPUN 16 03 08 F A0..
		6.0	16.5	3.18	0.8	TPUN 16 03 08 F A0..

Typ VCMW

	Abmessungen				Typ	
	α	l1 [mm]	l [mm]	s [mm]		r [mm]
7°		4.6	11.1	3.18	0.2	VCMW 11 03 02 F A0..
		4.1	11.1	3.18	0.4	VCMW 11 03 04 F A0..
		3.5	11.1	3.18	0.8	VCMW 11 03 08 F A0..
		6.0	16.6	4.76	0.2	VCMW 16 04 02 F A0..
		5.7	16.6	4.76	0.4	VCMW 16 04 04 F A0..
		4.8	16.6	4.76	0.8	VCMW 16 04 08 F A0..

Bestellinformationen

Verfügbare Ausführungen

Bestell-Code	DIAPACT(PKD)					CVD-Diam.	MKD	Naturdiam.
	A010	A020	A030	A040	A041	A060	A070	A080
Verfügbarkeit	✓	○	○	○	○	○	○	○
Weitere Infos	→ Seite 1-6					→ Seite 1-7		

✓ Auf Lager ○ Auf Anfrage, bitte Wunschtermin für die Lieferung angeben

Bestellbeispiel für:

Typ: CCMW 06 02 02 F A0..
Ausführung: MKD

- CCMW 06 02 02 F A070
- l1 = 3.7 mm¹⁾
- tt.mm.jj (Wunschtermin)

¹⁾ Die Schneidkantenlänge l1 sollte bei MKD- und Naturdiamant-Werkzeugen aus Kostengründen möglichst kurz gewählt werden.

**Radiengrösse lieferbar bis R 0.03mm
Fragen Sie uns an !!!!**



ISO-Schneidplatten mit Diamant-Schneiden positiv

■ Anwendung Aussen Schneidenausführung **Mehrweg**

Typ DCMT (Spanwinkel positiv Neutral)

		Abmessungen				Typ	
		α	β	l1 [mm]	l [mm]		s [mm]
	7°	6°	3.2	7.75	2.38	0.2	DCMT 07 02 02 F N A0..
			3.0	7.75	2.38	0.4	DCMT 07 02 04 F N A0..
			4.2	11.6	3.97	0.2	DCMT 11 T3 02 F N A0..
			4.0	11.6	3.97	0.4	DCMT 11 T3 04 F N A0..
			3.7	11.6	3.97	0.8	DCMT 11 T3 08 F N A0..

Typ VCMT (Spanwinkel positiv Neutral)

		Abmessungen				Typ	
		α	β	l1 [mm]	l [mm]		s [mm]
	7°	6°	4.6	11.1	3.18	0.2	VCMT 11 03 02 F N A0..
			4.1	11.1	3.18	0.4	VCMT 11 03 04 F N A0..
			3.5	11.1	3.18	0.8	VCMT 11 03 08 F N A0..
			6.0	16.6	4.76	0.2	VCMT 16 04 02 F N A0..
			5.7	16.6	4.76	0.4	VCMT 16 04 04 F N A0..
			4.8	16.6	4.76	0.8	VCMT 16 04 08 F N A0..

Typ DCMT (Spanwinkel positiv R/L)

		Abmessungen				Typ	
		α	β	l1 [mm]	l [mm]		s [mm]
	7°	6°	6.0	7.75	2.38	0.2	DCMT 07 02 02 F R/L A0..
			5.5	7.75	2.38	0.4	DCMT 07 02 04 F R/L A0..
			5.0	7.75	2.38	0.8	DCMT 07 02 08 F R/L A0..
			7.5	11.6	3.97	0.2	DCMT 11 T3 02 F R/L A0..
			7.0	11.6	3.97	0.4	DCMT 11 T3 04 F R/L A0..
			6.5	11.6	3.97	0.8	DCMT 11 T3 08 F R/L A0..

Typ VCMT (Spanwinkel positiv R/L)

		Abmessungen				Typ	
		α	β	l1 [mm]	l [mm]		s [mm]
	7°	6°	7.0	11.1	3.18	0.2	VCMT 11 03 02 F R/L A0..
			6.5	11.1	3.18	0.4	VCMT 11 03 04 F R/L A0..
			6.0	11.1	3.18	0.8	VCMT 11 03 08 F R/L A0..
			8.0	16.6	4.76	0.2	VCMT 16 04 02 F R/L A0..
			7.5	16.6	4.76	0.4	VCMT 16 04 04 F R/L A0..
			7.0	16.6	4.76	0.8	VCMT 16 04 08 F R/L A0..

Bestellinformationen

Verfügbare Ausführungen

Bestell-Code	DIAPACT(PKD)					CVD-Diam.	MKD	Naturdiam.
	A010	A020	A030	A040	A041			
Verfügbarkeit	✓	○	○	○	○	○	○	○
Weitere Infos	→ Seite 1-6				→ Seite 1-7			

✓ Auf Lager ○ Auf Anfrage, bitte Wunschtermin für die Lieferung angeben

Bestellbeispiel für:

Typ: **DCMT 07 02 02 F N A0..**
Ausführung: PKD A010

- **DCMT 07 02 02 F N A010**
- l1 = 3.2 mm¹⁾
- tt.mm.jj (Wunschtermin)

¹⁾ Die Schneidkantenlänge l1 sollte bei MKD- und Naturdiamant-Werkzeugen aus Kostengründen möglichst kurz gewählt werden.

Radiengrösse lieferbar bis R 0.03mm.

Fragen Sie uns an !!!!



ISO-Schneidplatten mit Diamant-Schneiden

Anwendung Innen | Schneidenausführung Einweg

ISO-Schneidplatten mit Diamant-Schneiden

- Anwendung Innen
- Schneidenausführung Einweg (E)

Typ CCMW

α	Abmessungen				Typ
	l1 [mm]	l [mm]	s [mm]	r [mm]	
7°	2.0	6.45	2.38	0.2	CCMW 06 02 02 F-E A0..
	2.0	6.45	2.38	0.4	CCMW 06 02 04 F-E A0..
	2.5	9.65	3.97	0.2	CCMW 09 T3 02 F-E A0..
	2.5	9.65	3.97	0.4	CCMW 09 T3 04 F-E A0..
	2.5	9.65	3.97	0.8	CCMW 09 T3 08 F-E A0..

Typ CPGW

α	Abmessungen				Typ
	l1 [mm]	l [mm]	s [mm]	r [mm]	
11°	2.0	6.45	2.38	0.2	CPGW 06 02 02 F-E A0..
	2.0	6.45	2.38	0.4	CPGW 06 02 04 F-E A0..

Typ DCMW

α	Abmessungen				Typ
	l1 [mm]	l [mm]	s [mm]	r [mm]	
7°	2.0	7.75	2.38	0.2	DCMW 07 02 02 F-E A0..
	2.0	7.75	2.38	0.4	DCMW 07 02 04 F-E A0..
	2.5	11.6	3.97	0.2	DCMW 11 T3 02 F-E A0..
	2.5	11.6	3.97	0.4	DCMW 11 T3 04 F-E A0..
	2.5	11.6	3.97	0.8	DCMW 11 T3 08 F-E A0..

Typ TPUN

α	Abmessungen				Typ
	l1 [mm]	l [mm]	s [mm]	r [mm]	
11°	2.5	16.5	3.19	0.2	TPUN 16 03 02 F-E A0..
	2.5	16.5	3.19	0.4	TPUN 16 03 04 F-E A0..

Typ VCMW

α	Abmessungen				Typ
	l1 [mm]	l [mm]	s [mm]	r [mm]	
7°	2.5	11.1	3.18	0.2	VCMW 11 03 02 F-E A0..
	2.5	11.1	3.18	0.4	VCMW 11 03 04 F-E A0..
	3.0	16.6	4.76	0.2	VCMW 16 04 02 F-E A0..
	3.0	16.6	4.76	0.4	VCMW 16 04 04 F-E A0..
	3.0	16.6	4.76	0.8	VCMW 16 04 08 F-E A0..

Bestellinformationen

Verfügbare Ausführungen

Bestell-Code	DIAPACT(PKD)					CVD-Diam.	MKD	Naturdiam.
	A010	A020	A030	A040	A041			
Verfügbarkeit	✓	○	○	○	○	○	○	○
Weitere Infos	→ Seite 1-6					→ Seite 1-7		

✓ Auf Lager ○ Auf Anfrage, bitte Wunschtermin für die Lieferung angeben

Bestellbeispiel für:

Typ: CCMW 06 02 02 F-E A0..
Ausführung: Naturdiamant

- CCMW 06 02 02 F-E A080
- l1 = 2.0 mm¹⁾
- tt.mm.jj (Wunschtermin)

¹⁾ Die Schneidkantenlänge l1 sollte bei MKD- und Naturdiamant-Werkzeugen aus Kostengründen möglichst kurz gewählt werden.

Radiengröße lieferbar bis R 0.03mm.

Fragen Sie uns an !!!!



ISO-Schneidplatten mit Diamant-Schneiden

- Anwendung Innen
- Schneidenausführung **Einweg – Doppelseitig (2E)**

Typ CCMW

	Abmessungen				Typ	
	α	l1 [mm]	l [mm]	s [mm]		r [mm]
	7°	2.0	6.45	2.38	0.2	CCMW 06 02 02 F-2E A0..
		2.0	6.45	2.38	0.4	CCMW 06 02 04 F-2E A0..
		2.5	9.65	3.97	0.2	CCMW 09 T3 02 F-2E A0..
		2.5	9.65	3.97	0.4	CCMW 09 T3 04 F-2E A0..
		2.5	9.65	3.97	0.8	CCMW 09 T3 08 F-2E A0..

Typ CPGW

	Abmessungen				Typ	
	α	l1 [mm]	l [mm]	s [mm]		r [mm]
	11°	2.0	6.45	2.38	0.2	CPGW 06 02 02 F-2E A0..
		2.0	6.45	2.38	0.4	CPGW 06 02 04 F-2E A0..

Typ DCMW

	Abmessungen				Typ	
	α	l1 [mm]	l [mm]	s [mm]		r [mm]
	7°	2.0	7.75	2.38	0.2	DCMW 07 02 02 F-2E A0..
		2.0	7.75	2.38	0.4	DCMW 07 02 04 F-2E A0..
		2.5	11.6	3.97	0.2	DCMW 11 T3 02 F-2E A0..
		2.5	11.6	3.97	0.4	DCMW 11 T3 04 F-2E A0..
		2.5	11.6	3.97	0.8	DCMW 11 T3 08 F-2E A0..

Typ VCMW

	Abmessungen				Typ	
	α	l1 [mm]	l [mm]	s [mm]		r [mm]
	7°	2.5	11.1	3.18	0.2	VCMW 11 03 02 F-2E A0..
		2.5	11.1	3.18	0.4	VCMW 11 03 04 F-2E A0..
		3.0	16.6	4.76	0.2	VCMW 16 04 02 F-2E A0..
		3.0	16.6	4.76	0.4	VCMW 16 04 04 F-2E A0..
		3.0	16.6	4.76	0.8	VCMW 16 04 08 F-2E A0..

Bestellinformationen

Verfügbare Ausführungen	DIAPACT(PKD)					CVD-Diam.	MKD	Naturdiam.
	A010	A020	A030	A040	A041	A060	A070	A080
Bestell-Code	A010	A020	A030	A040	A041	A060	A070	A080
Verfügbarkeit	✓	○	○	○	○	○	○	○
Weitere Infos	→ Seite 1-6					→ Seite 1-7		

✓ Auf Lager ○ Auf Anfrage, bitte Wunschtermin für die Lieferung angeben

Bestellbeispiel für:
 Typ: CCMW 06 02 02 F-2E A0..
 Ausführung: CVD-Diamant

- CCMW 06 02 02 F-2E A060
- l1 = 2.0 mm¹⁾
- tt.mm.jj (Wunschtermin)

¹⁾ Die Schneidkantenlänge l1 sollte bei MKD- und Naturdiamant-Werkzeugen aus Kostengründen möglichst kurz gewählt werden.

Radiengröße lieferbar bis R 0.03mm
Fragen Sie uns an !!!!



ISO-Schneidplatten mit Diamant-Schneiden

Anwendung Innen | Schneidenausführung Vollbelag

ISO-Schneidplatten mit Diamant-Schneiden

- Anwendung Innen
- Schneidenausführung **Vollbelag**

Typ TPUN

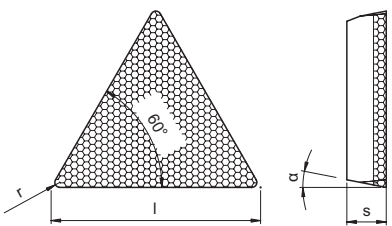
	Abmessungen				Typ	
	α		l [mm]	s [mm]		r [mm]
11°	Vollbelag		6.88	1.59	0.2	TPUN 06 01 02 -FV A0..
	Vollbelag		6.88	1.59	0.4	TPUN 06 01 04 -FV A0..
	Vollbelag		6.88	1.59	0.8	TPUN 06 01 08 -FV A0..

Bestellinformationen

Verfügbare Ausführungen	DIAPACT(PKD)					CVD-Diamant
	A010	A020	A030	A040	A041	A060
Bestell-Code						
Verfügbarkeit	✓	○	○	○	○	○
Weitere Infos	→ Seite 1-6					→ S. 1-7

✓ Auf Lager ○ Auf Anfrage, bitte Wunschtermin für die Lieferung angeben

Bestellbeispiel für:
 Typ: TPUN 06 01 02 -FV A0..
 Ausführung: DIAPACT A040

- TPUN 06 01 02 -FV A040
- tt.mm.jj (Wunschtermin)

**Radiengrösse lieferbar bis R 0.03mm
Fragen Sie uns an !!!!**





ISO-Schneidplatten mit Diamant-Schneiden

- Anwendung Aussen
- Schneidenausführung **Mehrweg**

Typ CCMW

		Abmessungen				Typ
		l1 [mm]	l [mm]	s [mm]	r [mm]	
	α					
	7°	4.6	12.9	4.76	0.4	CCMW 12 04 04 F A0..
		5.8	12.9	4.76	0.4	CCMW 12 04 04 F A0..
		4.5	12.9	4.76	0.8	CCMW 12 04 08 F A0..
		5.7	12.9	4.76	0.8	CCMW 12 04 08 F A0..

Typ CPGW

		Abmessungen				Typ
		l1 [mm]	l [mm]	s [mm]	r [mm]	
	α					
	11°	3.5	12.9	4.76	0.4	CPGW 12 04 04 F A0..
		5.8	12.9	4.76	0.4	CPGW 12 04 04 F A0..
		3.4	12.9	4.76	0.8	CPGW 12 04 08 F A0..
		5.7	12.9	4.76	0.8	CPGW 12 04 08 F A0..

Typ DCMW

		Abmessungen				Typ
		l1 [mm]	l [mm]	s [mm]	r [mm]	
	α					
	7°	6.0	15.5	4.76	0.4	DCMW 15 04 04 F A0..
		5.7	15.5	4.76	0.8	DCMW 15 04 08 F A0..

Typ SCMW

		Abmessungen				Typ
		l1 [mm]	l [mm]	s [mm]	r [mm]	
	7°	3.6	9.52	3.97	0.2	SCMW 09 T3 02 F A0..
		3.6	9.52	3.97	0.4	SCMW 09 T3 04 F A0..
		3.6	9.52	3.97	0.8	SCMW 09 T3 08 F A0..
		4.6	12.7	4.76	0.2	SCMW 12 04 02 F A0..
		6.1	12.7	4.76	0.2	SCMW 12 04 02 F A0..
		4.6	12.7	4.76	0.4	SCMW 12 04 04 F A0..
		6.1	12.7	4.76	0.4	SCMW 12 04 04 F A0..
		4.6	12.7	4.76	0.8	SCMW 12 04 08 F A0..
		6.1	12.7	4.76	0.8	SCMW 12 04 08 F A0..

Fortsetzung und Bestellinformationen siehe nächste Seite

**Radiengrösse lieferbar bis R 0.03mm
Fragen Sie uns an !!!!**



Typ SPUN

	Abmessungen				Typ	
	α	l1 [mm]	l [mm]	s [mm]		r [mm]
11°		3.6	9.52	3.18	0.2	SPUN 09 03 02 F A0..
		3.6	9.52	3.18	0.4	SPUN 09 03 04 F A0..
		4.6	12.7	3.18	0.2	SPUN 12 03 02 F A0..
		6.1	12.7	3.18	0.2	SPUN 12 03 02 F A0..
		4.6	12.7	3.18	0.4	SPUN 12 03 04 F A0..
		6.1	12.7	3.18	0.4	SPUN 12 03 04 F A0..
		4.6	12.7	3.18	0.8	SPUN 12 03 08 F A0..
		6.1	12.7	3.18	0.8	SPUN 12 03 08 F A0..

Bestellinformationen

Verfügbare Ausführungen

Bestell-Code	DIAPACT(PKD)					CVD-Diam.	MKD	Naturdiam.
	A010	A020	A030	A040	A041			
Verfügbarkeit	✓	○	○	○	○	○	○	○
Weitere Infos	→ Seite 1-6					→ Seite 1-7		

✓ Auf Lager ○ Auf Anfrage, bitte Wunschtermin für die Lieferung angeben

Bestellbeispiel für:

Typ: CCMW 12 04 08 F A0..

Ausführung: MKD

- CCMW 12 04 04 F A070
- l1 = 5.8 mm¹⁾
- tt.mm.jj (Wunschtermin)

¹⁾ Die Schneidkantenlänge l1 sollte bei MKD- und Naturdiamant-Werkzeugen aus Kostengründen möglichst kurz gewählt werden.

Radiengröße lieferbar bis R 0.03mm

Fragen Sie uns an !!!!



ISO-Schneidplatten mit Diamant-Schneiden

Anwendung Aussen | Schneidenausführung Einweg

ISO-Schneidplatten mit Diamant-Schneiden

- Anwendung Aussen
- Schneidenausführung **Einweg (E)**

Typ CCMW

		Abmessungen				Typ
		α	l1 [mm]	l [mm]	s [mm]	
	7°	2.5	12.9	4.76	0.4	CCMW 12 04 04 F-E A0..
		2.5	12.9	4.76	0.8	CCMW 12 04 08 F-E A0..

Typ SCMW

		Abmessungen				Typ
		α	l1 [mm]	l [mm]	s [mm]	
	7°	2.5	9.52	3.97	0.2	SCMW 09 T3 02 F-E A0..
		2.5	9.52	3.97	0.4	SCMW 09 T3 04 F-E A0..
		2.5	9.52	3.97	0.8	SCMW 09 T3 08 F-E A0..
		2.5	12.7	4.76	0.2	SCMW 12 04 02 F-E A0..
		2.5	12.7	4.76	0.4	SCMW 12 04 04 F-E A0..
		2.5	12.7	4.76	0.8	SCMW 12 04 08 F-E A0..

Typ SPUN

		Abmessungen				Typ
		α	l1 [mm]	l [mm]	s [mm]	
	11°	2.5	12.7	3.18	0.2	SPUN 12 03 02 F-E A0..
		2.5	12.7	3.18	0.4	SPUN 12 03 04 F-E A0..

Bestellinformationen

Verfügbare Ausführungen	DIAPACT(PKD)					CVD-Diam.	MKD	Naturdiam.
	A010	A020	A030	A040	A041	A060	A070	A080
Bestell-Code	A010	A020	A030	A040	A041	A060	A070	A080
Verfügbarkeit	✓	○	○	○	○	○	○	○
Weitere Infos	→ Seite 1-6					→ Seite 1-7		

Auf Lager Auf Anfrage, bitte Wunschtermin für die Lieferung angeben

Bestellbeispiel für:
 Typ: CCMW 12 04 04 F-E A0..
 Ausführung: CVD-Diamant

- CCMW 12 04 04 F-E A060
- l1 = 2.5 mm¹⁾
- tt.mm.jj (Wunschtermin)

¹⁾ Die Schneidkantenlänge l1 sollte bei MKD- und Naturdiamant-Werkzeugen aus Kostengründen möglichst kurz gewählt werden.

Radiengröße lieferbar bis R 0.03mm

Fragen Sie uns an !!!!



ISO-Schneidplatten mit Diamant-Schneiden

- Anwendung Aussen
- Schneidenausführung **Einweg – Doppelseitig (2E)**

Typ CCMW

	Abmessungen				Typ	
	α	l1 [mm]	l [mm]	s [mm]		r [mm]
	7°	2.5	12.9	4.76	0.4	CCMW 12 04 04 F-2E A0..
		2.5	12.9	4.76	0.8	CCMW 12 04 08 F-2E A0..

Typ SCMW

	Abmessungen				Typ	
	α	l1 [mm]	l [mm]	s [mm]		r [mm]
	7°	2.5	9.52	3.97	0.2	SCMW 09 T3 02 F-2E A0..
		2.5	9.52	3.97	0.4	SCMW 09 T3 04 F-2E A0..
		2.5	9.52	3.97	0.8	SCMW 09 T3 08 F-2E A0..
		2.5	12.7	4.76	0.2	SCMW 12 04 02 F-2E A0..
		2.5	12.7	4.76	0.4	SCMW 12 04 04 F-2E A0..
		2.5	12.7	4.76	0.8	SCMW 12 04 08 F-2E A0..

Typ SPUN

	Abmessungen				Typ	
	α	l1 [mm]	l [mm]	s [mm]		r [mm]
	11°	2.5	12.7	3.18	0.2	SPUN 12 03 02 F-2E A0..
		2.5	12.7	3.18	0.4	SPUN 12 03 04 F-2E A0..

Bestellinformationen

Verfügbare Ausführungen	DIAPACT(PKD)					CVD-Diam.	MKD	Naturdiam.
	A010	A020	A030	A040	A041	A060	A070	A080
Bestell-Code	A010	A020	A030	A040	A041	A060	A070	A080
Verfügbarkeit	✓	○	○	○	○	○	○	○
Weitere Infos	→ Seite 1-6					→ Seite 1-7		

✓ Auf Lager ○ Auf Anfrage, bitte Wunschtermin für die Lieferung angeben

Bestellbeispiel für:
 Typ: CCMW 12 04 04 F-2E A0..
 Ausführung: MKD

- CCMW 12 04 04 F-2E A070
- l1 = 2.5 mm¹⁾
- tt.mm.jj (Wunschtermin)

¹⁾ Die Schneidkantenlänge l1 sollte bei MKD- und Naturdiamant-Werkzeugen aus Kostengründen möglichst kurz gewählt werden.

Radiengrösse lieferbar bis R 0.03mm
Fragen Sie uns an !!!!



Produktspektrum

ISO-Schneidplatten mit CVD-Diamant-Schneiden, Anwendung aussen → [Seite 1-41](#)

Vorteile im Überblick

- Engste Masstoleranzen und feinste Oberflächen
- Höchste Standzeiten
- Minimierte Ausschussraten
- Geringe oder keine Gratbildung

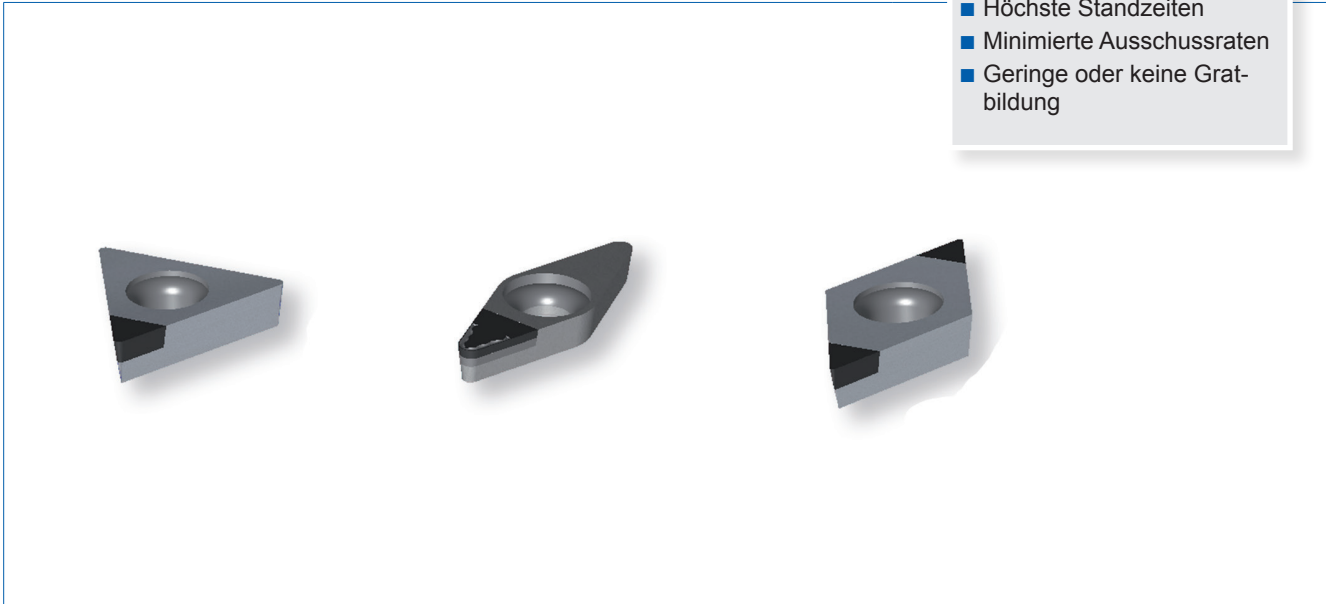

Produktmerkmale

- CVD-Dickschicht vakuumgelötet auf handelsübliche Hartmetallwendeplatten .
- Beste Schneidkantengüte
- Schartigkeit der Schneide wird mittels Laser erstellt

Anwendungsbereiche

Werkzeuge mit CVD-Diamantschneiden erzielen hervorragende Ergebnisse im Bereich Standzeit, Oberflächengüten, Produktionszeiten und sind somit vor allem geeignet bei hohen Stückzahlen oder bei hohem Werkzeugverschleiss.

Durch die hohe Abriebfestigkeit ergeben sich sehr hohe Nutzungszeiten der Werkzeuge und somit geringe Stillstandzeiten der Produktionsmaschinen.

CVD-Diamant-Schneidplatten

Al-Si-Legierungen ab 13 % Si

MMCs

GFK/Grafit

Wolfram

Thermoplast mit Kohlefaser,
Teflon mit hohem Glasanteil

Einsatzbedingungen

- Schneiden nie mechanisch vermessen (Ausbruchgefahr).
- Schneidplatten vor Schneidenbruch nachschleifen lassen.
- Für unterbrochenen Schnitt Schnittwerte ca. halbieren.
- Intensive Kühlung mit leichter Bohremulsion verbessert die Schnittleistung erheblich.
- Möglichst hohe Schnittwerte anstreben, um so die Reibung zu reduzieren und dadurch die Standzeit der Schneidplatte zu erhöhen.



ISO-Schneidplatten mit CVD-Diamant-Schneiden

- Anwendung Innen
- Schneidenausführung Einweg

Typ CCGW

α	Abmessungen				Typ
	l1 [mm]	l [mm]	s [mm]	r [mm]	
7°	2.0	6.45	2.38	0.2	CCGW 06 02 02 F-E LC A060
	2.0	6.45	2.38	0.4	CCGW 06 02 04 F-E LC A060
	2.5	9.65	3.97	0.2	CCGW 09 T3 02 F-E LC A060
	2.5	9.65	3.97	0.4	CCGW 09 T3 04 F-E LC A060

Typ CPGW

α	Abmessungen				Typ
	l1 [mm]	l [mm]	s [mm]	r [mm]	
11°	2.0	6.45	2.38	0.2	CPGW 06 02 02 F-E LC A060
	2.0	6.45	2.38	0.4	CPGW 06 02 04 F-E LC A060
	2.5	12.9	4.76	0.2	CPGW 12 04 02 F-E LC A060
	2.5	12.9	4.76	0.4	CPGW 12 04 04 F-E LC A060

Typ DCGW

α	Abmessungen				Typ
	l1 [mm]	l [mm]	s [mm]	r [mm]	
7°	2.0	7.75	2.38	0.2	DCGW 07 02 02 F-E LC A060
	2.0	7.75	2.38	0.4	DCGW 07 02 04 F-E LC A060
	2.5	11.6	3.97	0.2	DCGW 11 T3 02 F-E LC A060
	2.5	11.6	3.97	0.4	DCGW 11 T3 04 F-E LC A060

Typ VCGW

α	Abmessungen				Typ
	l1 [mm]	l [mm]	s [mm]	r [mm]	
7°	2.5	11.1	3.18	0.2	VCGW 11 03 02 F-E LC A060
	2.2	11.1	3.18	0.4	VCGW 11 03 04 F-E LC A060
	3.0	16.6	4.76	0.2	VCGW 16 04 02 F-E LC A060
	2.7	16.6	4.76	0.4	VCGW 16 04 04 F-E LC A060

Bestellinformationen

Verfügbare Ausführungen

	CVD-Diamant
Bestell-Code	A060
Verfügbarkeit	○
Weitere Infos	→ Seite 1-7

✓ Auf Lager ○ Auf Anfrage, bitte Wunschtermin für die Lieferung angeben
Auf Wunsch können die Schneidplatten auch mit Spanbrecher geliefert werden!

Bestellbeispiel für:

Typ: VCGW 11 03 02 F-E LC
Ausführung: CVD A060

- VCGW 11 03 02 F-E LC A060
- l1 = 2.5 mm
- tt.mm.jj (Wunschtermin)

Typ SPUN



ISO-Schneidplatten mit gelaserten CVD-DIAMANT-Schneiden

Anwendung Aussen/Innen | positive Schneidenausführung Mehrweg

ISO-Schneidplatten mit CVD-Diamant-Schneiden POSITIV

- Anwendung aussen
- Schneidenausführung **Mehrweg**

Typ **DCGT** Spanwinkel positiv Neutral

		Abmessungen				Typ
α	β	l1 [mm]	l [mm]	s [mm]	r [mm]	
7°	6°	3.2	7.75	2.38	0.2	DCGT 07 02 02 F-N LC A060
		3.0	7.75	2.38	0.4	DCGT 07 02 04 F-N LC A060
		4.2	11.6	3.97	0.2	DCGT 11 T3 02 F-N LC A060
		4.0	11.6	3.97	0.4	DCGT 11 T3 04 F-N LC A060

Typ **VCGT** (Spanwinkel positiv Neutral)

		Abmessungen				Typ
α	β	l1 [mm]	l [mm]	s [mm]	r [mm]	
7°	6°	2.0	6.45	2.38	0.2	VCGT 11 03 02 F-N LC A060
		2.0	6.45	2.38	0.4	VCGT 11 03 04 F-N LC A060
		2.5	12.9	4.76	0.2	VCGT 16 04 02 F-N LC A060
		2.5	12.9	4.76	0.4	VCGT 16 04 04 F-N LC A060

Typ **DCGT** (Spanwinkel positiv R/L)

		Abmessungen				Typ
α	β	l1 [mm]	l [mm]	s [mm]	r [mm]	
7°	6°	6.0	7.75	2.38	0.2	DCGT 07 02 02 F R/L LC A0..
		5.5	7.75	2.38	0.4	DCGT 07 02 04 F R/L LC A0..
		5.0	7.75	2.38	0.8	DCGT 07 02 08 F R/L LC A0..
		7.5	11.6	3.97	0.2	DCGT 11 T3 02 F R/L LC A0..
		7.0	11.6	3.97	0.4	DCGT 11 T3 04 F R/L LC A0..
		6.5	11.6	3.97	0.8	DCGT 11 T3 08 F R/L LC A0..

Typ **VCGT**(Spanwinkel positiv R/L)

		Abmessungen				Typ
α	β	l1 [mm]	l [mm]	s [mm]	r [mm]	
7°	6°	7.0	11.1	3.18	0.2	VCGT 11 03 02 F R/L LC A0..
		6.5	11.1	3.18	0.4	VCGT 11 03 04 F R/L LC A0..
		6.0	11.1	3.18	0.8	VCGT 11 03 08 F R/L LC A0..
		8.0	16.6	4.76	0.2	VCGT 16 04 02 F R/L LC A0..
		7.5	16.6	4.76	0.4	VCGT 16 04 04 F R/L LC A0..
		7.0	16.6	4.76	0.8	VCGT 16 04 08 F R/L LC A0..

Bestellinformationen

Verfügbare Ausführungen

	CVD-Diamant
Bestell-Code	A060
Verfügbarkeit	○
Weitere Infos	→ Seite 1-7

✓ Auf Lager ○ Auf Anfrage, bitte Wunschtermin für die Lieferung angeben
Auf Wunsch können die Schneidplatten auch mit Spanbrecher geliefert werden!

Bestellbeispiel für:
Typ: VCGT 11 03 02 F-R LC
Ausführung: CVD A060

- VCGT 11 03 02 F-R LC A060
- l1 = 7.0 mm
- tt.mm.jj (Wunschtermin)

Typ **SPUN**





Produktspektrum

- Mit BORAPACT (CBN)-Schneiden für Innenbearbeitung → Seite 1-45
- Mit BORAPACT (CBN)-Schneiden für Aussenbearbeitung → Seite 1-47
- Mit Diamant-Schneiden für Innenbearbeitung → Seite 1-50
- Mit Diamant-Schneiden für Aussenbearbeitung → Seite 1-52

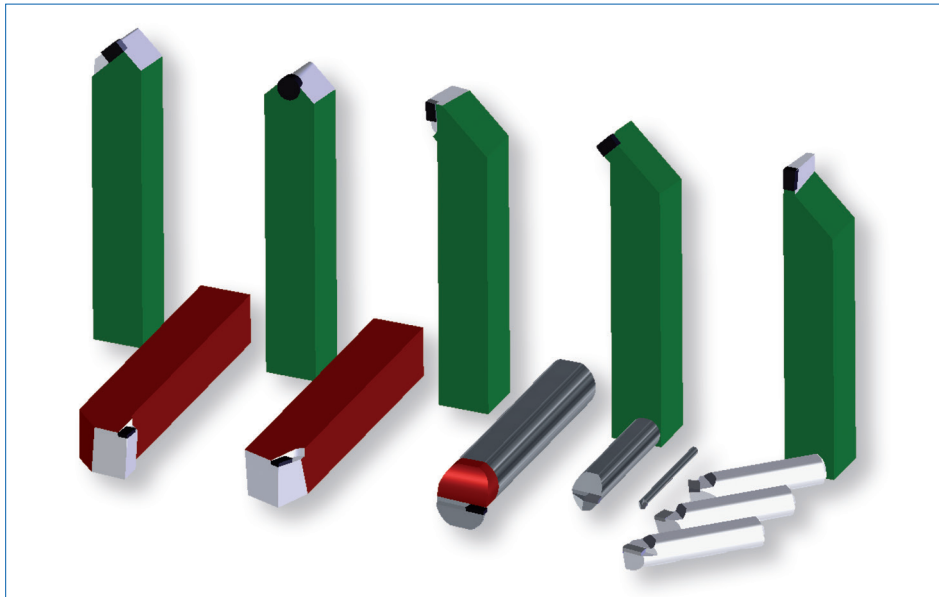

Vorteile im Überblick

BORAPACT(CBN)

- Drehen von gehärteten Teilen ist wirtschaftlicher als Schleifen
- Geeignet für höchste Ansprüche
- Ausgezeichnete Abriebfestigkeit
- Hohe Verschleissfestigkeit
- Hervorragende chemische Stabilität

Diamant

- Engste Masstoleranzen und feinste Oberflächen
- Höchste Standzeiten
- Minimierte Ausschussraten
- Geringe oder keine Gratbildung

Produktmerkmale

- BORAPACT(CBN)- oder Diamant-Rohlinge hart- oder vakuumgelötet auf Stahl- oder HM-Schäfte
- Formen gemäss DIN oder nach Herstellerangaben
- CBN- und Diamant-Sorten je nach Anwendung unterschiedlich

Anwendungsbereiche

Durch die direkte Lötung auf den Trägerkörper sind die Werkzeuge geeignet für:

BORAPACT(CBN)-Schaftwerkzeuge

- Wellen und Spindeln
- Nachbearbeitung von hart aufgespritzten Schichten
- Abdrehen einsatzgehärteter Schichten an Wellen etc.
- Nuteneinstiche für Seeger-, Spann- und O-Ring-Einstiche an gehärteten Werkstücken
- Reparaturen an gehärteten Werkstücken
- Werkstücke aus hartem Stahlguss
- Bohrungen ausdrehen anstatt schleifen

DIAMANT-Schaftwerkzeuge

- Aluminiumbearbeitung mit hohem Spanvolumen
- Titanbearbeitung
- Kollektoren
- Kunststoff- und NE-Metall-Decolletage
- Elektroden, Grafitformen
- Keramikteile
- Hochglanzbearbeitung von Acrylglas
- Bearbeitung von Uhrenteilen

Einsatzbedingungen

BORAPACT(CBN)-Schaftwerkzeuge

- Stabil gelagerte Maschine mit spielfreien Führungen
- Kühlung unbedingt notwendig
Ausnahme: Kleine Schnitttiefen von 0.1 mm – 0.2 mm
- Schnittgeschwindigkeit v: generell 80 m/min – 150 m/min
- Schnitttiefe a: max. 1 mm, bei unterbrochenem Schnitt 0.3 mm – 0.4 mm.
Aufgrund des geringen Schnittdruckes können Schnitttiefen von 0.005 mm gefahren werden.
- Vorschub s: max. 0.1 mm/Umdrehung, bei unterbrochenem Schnitt 0.03 – 0.05 mm/Umdrehung

DIAMANT-Schaftwerkzeuge

- Stabil gelagerte Maschine mit spielfreien Führungen
- Kühlung je nach Schneidstoff von Vorteil
Ausnahme: Kleine Schnitttiefen von 0.1 mm – 0.2 mm
- Schnittgeschwindigkeit v: bis 2800 m/min möglich, jedoch nicht Voraussetzung
- Schnitttiefe a: max. Schneidenlänge der Diamant-Schneide minus 0.5 mm.
Aufgrund des geringen Schnittdruckes können Schnitttiefen von 0.005 mm gefahren werden.
- Bei hohen Spanquerschnitten ist unbedingt auf eine ausreichende Wärmeableitung (Kühlung) zu achten, um eine Selbstablötung der DIAPACT PKD-Schneide zu verhindern.



Schaftwerkzeuge mit BORAPACT (CBN)-Schneiden

- Für Innenbearbeitung
- Anwendung **Ausbohren**

2121 Ausbohrstahl

	Abmessungen							Typ
	h [mm]	Ød [mm]	l [mm]	l1-0.2 [mm]	r [mm]	c [mm]	Ød-min [mm]	
5	6	100	4	0.4	2	8	B 2121 R/L6 B0..	
7	8	120	5	0.4	2	10	B 2121 R/L8 B0..	
9	10	140	5	0.4	3	13	B 2121 R/L10 B0..	
11	12	160	8	0.8	3	15	B 2121 R/L12 B0..	
14	16	180	8	0.8	4	20	B 2121 R/L16 B0..	
18	20	200	8	0.8	4	24	B 2121 R/L20 B0..	
23	25	250	8	1.2	4	29	B 2121 R/L25 B0..	

2870 Bohrstangeneinsatz, Typ A, Ausbohrstahl

	Abmessungen						passend zu Aufnahme	Typ
	Ød [mm]	l [mm]	l1-0.2 [mm]	h1 [mm]	h2 [mm]	r [mm]		
8	35	5	6	7	0.4	2855-20	B 2870-8-A B0..	
10	45	8	8	9	0.8	2855-25	B 2870-10-A B0..	
12	55	8	10	11	0.8	2855-32	B 2870-12-A B0..	
14	70	8	12	13	0.8	2855-40	B 2870-14-A B0..	
16	90	8	14	15	1.2	2855-50	B 2870-16-A B0..	

Bestellinformationen

Verfügbare Ausführungen

Bestell-Code	BORAPACT(CBN)			
	B010	B020	B040	B050
Verfügbarkeit	✓	○	○	○
Weitere Infos	→ Seite 1-5			

✓ Auf Lager ○ Auf Anfrage, bitte Wunschtermin für die Lieferung angeben

Bestellbeispiel für:

Typ: B 2121 R/L6 B0..
Ausführung R: BORAPACT B020

- B 2121 R6 B020
- tt.mm.jj (Wunschtermin)



Schaftwerkzeuge mit BORAPACT (CBN)-Schneiden

- Für Innenbearbeitung
- Anwendung **Sacklochbohren**

2123 Inneneckstahl

	Abmessungen							Typ
	h [mm]	Ød [mm]	l [mm]	l1-0.2 [mm]	r [mm]	c [mm]	Ød-min [mm]	
	5	6	100	4	0.4	2	8	B 2123 R/L6 B0..
	7	8	120	5	0.4	2	10	B 2123 R/L8 B0..
	9	10	140	5	0.4	3	13	B 2123 R/L10 B0..
	11	12	160	8	0.8	3	15	B 2123 R/L12 B0..
	14	16	180	8	0.8	4	20	B 2123 R/L16 B0..
	18	20	200	8	0.8	4	24	B 2123 R/L20 B0..
	23	25	250	8	1.2	4	29	B 2123 R/L25 B0..

2125 Inneneckstahl, HM-Schaft (ab Ø5 auch mit Innenkühlung lieferbar)

	Abmessungen					passend zu Aufnahme	Typ
	Ød [mm]	l [mm]	l1-0.2 [mm]	f _{max} [mm]	r [mm]		
	2	50	3	2.5	0.2	1)	B 2125 R/L2 B0..
	3	50	3	3.5	0.2	1)	B 2125 R/L3 B0..
	4	60	4	4.7	0.2	2840-04	B 2125 R/L4 B0..
	5	60	4	5.7	0.4	2840-05	B 2125 R/L5 B0..
	6	80	5	7.0	0.4	2840-06	B 2125 R/L6 B0..
	8	100	5	9.0	0.4	2840-08	B 2125 R/L8 B0..
	10	100	8	11.0	0.4	2840-10	B 2125 R/L10 B0..
	12	100	8	13.0	0.8	2840-12	B 2125 R/L12 B0..
	16	150	10	17.0	0.8	2840-16	B 2125 R/L16 B0..
	20	150	10	21.0	0.8	1)	B 2125 R/L20 B0..

1) Spannung mittels Spannzange

2870 Bohrstangeneinsatz, Typ B, Inneneckstahl

	Abmessungen						passend zu Aufnahme	Typ
	Ød [mm]	l [mm]	l1-0.2 [mm]	h1 [mm]	h2 [mm]	r [mm]		
	8	35	5	6	7	0.4	2855-20	B 2870-8-B B0..
	10	45	8	8	9	0.8	2855-25	B 2870-10-B B0..
	12	55	8	10	11	0.8	2855-32	B 2870-12-B B0..
	14	70	8	12	13	0.8	2855-40	B 2870-14-B B0..
	16	90	8	14	15	1.2	2855-50	B 2870-16-B B0..

Bestellinformationen

Verfügbare Ausführungen	BORAPACT(CBN)			
	B010	B020	B040	B050
Bestell-Code	B010	B020	B040	B050
Verfügbarkeit	✓	○	○	○
Weitere Infos	→ Seite 1-5			

✓ Auf Lager ○ Auf Anfrage, bitte Wunschtermin für die Lieferung angeben

Bestellbeispiel für:
 Typ: B 2125 R/L2 B0..
 Ausführung L: BORAPACT B050

- B 2125 L2 B050
- tt.mm.jj (Wunschtermin)



Schaftwerkzeuge mit BORAPACT (CBN)-Schneiden

- Für Aussenbearbeitung
- Anwendung **Längsdrehen**

2110 Schlichtstahl, mittig

	Abmessungen					Typ
	h [mm]	b [mm]	l [mm]	l1-0.2 [mm]	r [mm]	
	10	10	90	8	0.4	B 2110 R/L10 B0..
	12	12	100	8	0.4	B 2110 R/L12 B0..
	16	16	110	8	0.8	B 2110 R/L16 B0..
	20	20	125	8	0.8	B 2110 R/L20 B0..
	25	20	140	8	0.8	B 2110 R/L25 B0..
	32	25	170	8	1.2	B 2110 R/L32 B0..

2111 Radiusstahl

	Abmessungen				Typ
	h [mm]	b [mm]	l [mm]	r [mm]	
	10	10	90	4	B 2111/10 B0..
	12	12	100	4	B 2111/12 B0..
	16	16	110	4	B 2111/16 B0..
	20	20	125	4	B 2111/20 B0..
	25	20	140	4	B 2111/25 B0..
	32	32	170	4	B 2111/32 B0..

2112 Schlichtstahl, gerade

	Abmessungen					Typ
	h [mm]	b [mm]	l [mm]	l1-0.2 [mm]	r [mm]	
	10	10	90	8	0.4	B 2112 R/L10 B0..
	12	12	100	8	0.4	B 2112 R/L12 B0..
	16	16	110	8	0.8	B 2112 R/L16 B0..
	20	20	125	8	0.8	B 2112 R/L20 B0..
	25	20	140	8	0.8	B 2112 R/L25 B0..
	32	25	170	8	1.2	B 2112 R/L32 B0..

2113 Messerstahl

	Abmessungen						Typ
	h [mm]	b [mm]	l [mm]	l1-0.2 [mm]	r [mm]	c [mm]	
	10	10	90	8	0.2	4	B 2113 R/L10 B0..
	12	12	100	8	0.4	4	B 2113 R/L12 B0..
	16	16	110	8	0.8	4	B 2113 R/L16 B0..
	20	20	125	8	0.8	5	B 2113 R/L20 B0..
	25	20	140	8	0.8	5	B 2113 R/L25 B0..
	32	25	170	8	1.2	5	B 2113 R/L32 B0..

Bestellinformationen

Verfügbare Ausführungen

Bestell-Code	BORAPACT(CBN)			
	B010	B020	B040	B050
Verfügbarkeit	✓	○	○	○
Weitere Infos	→ Seite 1-5			

✓ Auf Lager ○ Auf Anfrage, bitte Wunschtermin für die Lieferung angeben

Bestellbeispiel für:

Typ: B 2111/25 B0..
Ausführung: BORAPACT B040

- B 2111/25 B040
- tt.mm.jj (Wunschtermin)



Schaftwerkzeuge mit BORAPACT (CBN)-Schneiden

- Für Aussenbearbeitung
- Anwendung Plan- und Längsdrehen

2114 Eckstahl

	Abmessungen						Typ
	h [mm]	b [mm]	l [mm]	l1-0.2 [mm]	r [mm]	c [mm]	
6° negativ	10	10	90	8	0.4	4	B 2114 R/L10 B0..
	12	12	100	8	0.4	4	B 2114 R/L12 B0..
	16	16	110	8	0.8	4	B 2114 R/L16 B0..
	20	20	125	8	0.8	5	B 2114 R/L20 B0..
	25	20	140	8	0.8	5	B 2114 R/L25 B0..
	32	25	170	8	1.2	5	B 2114 R/L32 B0..

2117 Schlichtstahl, gebogen

	Abmessungen						Typ
	h [mm]	b [mm]	l [mm]	l1-0.2 [mm]	r [mm]	c [mm]	
6° negativ	10	10	90	8	0.8	6	B 2117 R/L10 B0..
	12	12	100	8	0.8	6	B 2117 R/L12 B0..
	16	16	110	8	0.8	6	B 2117 R/L16 B0..
	20	20	125	8	0.8	6	B 2117 R/L20 B0..
	25	20	140	8	1.2	7	B 2117 R/L25 B0..
	32	25	170	8	1.2	7	B 2117 R/L32 B0..

Bestellinformationen

Verfügbare Ausführungen

Bestell-Code	BORAPACT(CBN)			
	B010	B020	B040	B050
Verfügbarkeit	✓	○	○	○
Weitere Infos	→ Seite 1-5			

✓ Auf Lager ○ Auf Anfrage, bitte Wunschtermin für die Lieferung angeben

Bestellbeispiel für:

Typ: B 2117 R/L16 B0..

Ausführung R: BORAPACT B050

- B 2117 R16 B050
- tt.mm.jj (Wunschtermin)



Schaftwerkzeuge mit BORAPACT (CBN)-Schneiden

- Für Aussenbearbeitung
- Anwendung **Ein- und Abstechen**

2115 Einstechstahl

	Abmessungen					Typ
	h [mm]	b [mm]	l [mm]	l1-0.2 [mm]	t [mm]	
	10	10	90	bis 3.3	6	B 2115 R/L10 B0..
	12	12	100	bis 3.3	6	B 2115 R/L12 B0..
	16	16	110	bis 7.8	9	B 2115 R/L16 B0..
	20	20	125	3.3 – 7.8	10	B 2115 R/L20 B0..
	25	20	140	3.3 – 7.8	10	B 2115 R/L25 B0..

Bestellinformationen

Verfügbare Ausführungen

	BORAPACT(CBN)			
	B010	B020	B040	B050
Bestell-Code				
Verfügbarkeit	✓	○	○	○
Weitere Infos	→ Seite 1-5			

✓ Auf Lager ○ Auf Anfrage, bitte Wunschtermin für die Lieferung angeben

Bestellbeispiel für:

Typ: B 2115 R/L10 B0..

Ausführung R: BORAPACT B020

- B 2115 R10 B020
- tt.mm.jj (Wunschtermin)
- Einstechbreite l1 [mm]
- Einstechtiefe t [mm]



Schaftwerkzeuge mit Diamant-Schneiden

Für Innenbearbeitung | Anwendung Ausbohren

Schaftwerkzeuge mit Diamant-Schneiden

- Für Innenbearbeitung
- Anwendung **Ausbohren**

2870 Bohrstangeneinsatz, Typ A, Ausbohrstahl

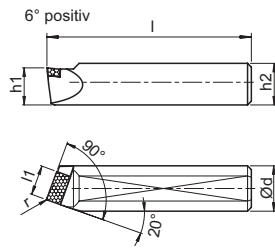

Ød [mm]	l [mm]	Abmessungen				r [mm]	passend zu Auf- nahme	Typ
		l1-0.2 [mm]	h1 [mm]	h2 [mm]				
8	35	5	6	7	0.4	2855-20	D 2870-8-A A0..	
10	45	8	8	9	0.8	2855-25	D 2870-10-A A0..	
12	55	8	10	11	0.8	2855-32	D 2870-12-A A0..	
14	70	8	12	13	0.8	2855-40	D 2870-14-A A0..	
16	90	8	14	15	0.8	2855-50	D 2870-16-A A0..	

Bestellinformationen

Verfügbare Ausführungen

Bestell-Code	DIAPACT(PKD)					CVD- Diam.	MKD	Natur- diam.
	A010	A020	A030	A040	A041			
Verfügbarkeit	✓	○	○	○	○	○	○	○
Weitere Infos	→ Seite 1-6					→ Seite 1-7		

✓ Auf Lager ○ Auf Anfrage, bitte Wunschtermin für die Lieferung angeben

Bestellbeispiel für:

Typ: D 2870-10-A A0..
Ausführung: Naturdiamant

- D 2870-10-A A080
- tt.mm.jj (Wunschtermin)

Die Schneidkantenlänge l1 kann angegeben werden und sollte bei MKD- und Naturdiamant-Werkzeugen aus Kostengründen möglichst kurz gewählt werden.



Schaftwerkzeuge mit Diamant-Schneiden

- Für Innenbearbeitung
- Anwendung **Sacklochbohren**

2123 Inneneckstahl

	Abmessungen							Typ
	h [mm]	Ød [mm]	l [mm]	l1-0.2 [mm]	r [mm]	c [mm]	Ød-min [mm]	
	5	6	100	4	0.2	2	8	D 2123 R/L6 A0..
	7	8	120	5	0.2	2	10	D 2123 R/L8 A0..
	9	10	140	5	0.4	3	13	D 2123 R/L10 A0..
	11	12	160	8	0.4	3	15	D 2123 R/L12 A0..
	14	16	180	8	0.8	4	20	D 2123 R/L16 A0..
	18	20	200	8	0.8	4	24	D 2123 R/L20 A0..
	23	25	250	8	0.8	4	29	D 2123 R/L25 A0..

2125 Inneneckstahl, HM-Schaft (ab Ø5 auch mit Innenkühlung lieferbar)

	Abmessungen					passend zu Aufnahme	Typ
	Ød [mm]	l [mm]	l1-0.2 [mm]	f _{max} [mm]	r [mm]		
	2	50	0.5	2.5	0.2	1)	D 2125 R/L2 A0..
	3	50	0.5	3.5	0.2	1)	D 2125 R/L3 A0..
	4	60	4	4.7	0.2	2840-04	D 2125 R/L4 A0..
	5	60	4	5.7	0.2	2840-05	D 2125 R/L5 A0..
	6	80	5	7.0	0.2	2840-06	D 2125 R/L6 A0..
	8	100	5	9.0	0.4	2840-08	D 2125 R/L8 A0..
	10	100	8	11.0	0.4	2840-10	D 2125 R/L10 A0..
	12	100	8	13.0	0.4	2840-12	D 2125 R/L12 A0..
	16	150	10	17.0	0.4	2840-16	D 2125 R/L16 A0..
	20	150	10	21.0	0.4	1)	D 2125 R/L20 A0..

1) Spannung mittels Spannzange

2870 Bohrstangeneinsatz, Typ B, Inneneckstahl

	Abmessungen						passend zu Aufnahme	Typ
	Ød [mm]	l [mm]	l1-0.2 [mm]	h1 [mm]	h2 [mm]	r [mm]		
	8	35	5	6	7	0.4	2855-20	D 2870-8-B A0..
	10	45	8	8	9	0.8	2855-25	D 2870-10-B A0..
	12	55	8	10	11	0.8	2855-32	D 2870-12-B A0..
	14	70	8	12	13	0.8	2855-40	D 2870-14-B A0..
	16	90	8	14	15	0.8	2855-50	D 2870-16-B A0..

Bestellinformationen

Verfügbare Ausführungen

Bestell-Code	DIAPACT(PKD)					CVD-Diam.	MKD	Naturdiam.
	A010	A020	A030	A040	A041			
Verfügbarkeit	✓	○	○	○	○	○	○	○
Weitere Infos	→ Seite 1-6					→ Seite 1-7		

✓ Auf Lager ○ Auf Anfrage, bitte Wunschtermin für die Lieferung angeben

Bestellbeispiel für:

Typ: D 2123 R/L6 A0..
Ausführung L: Naturdiamant

- D 2123 L6 A080
- tt.mm.jj (Wunschtermin)

Die Schneidkantenlänge l1 kann angegeben werden und sollte bei MKD- und Naturdiamant-Werkzeugen aus Kostengründen möglichst kurz gewählt werden.



Schaftwerkzeuge mit Diamant-Schneiden

- Für Aussenbearbeitung
- Anwendung **Längsdrehen**

2110 Schlichtstahl, mittig

	Abmessungen					Typ
	h [mm]	b [mm]	l [mm]	l1-0.2 [mm]	r [mm]	
10	10	90	8	0.4	D 2110 R/L10 A0..	
12	12	100	8	0.4	D 2110 R/L12 A0..	
16	16	110	8	0.8	D 2110 R/L16 A0..	
20	20	125	8	0.8	D 2110 R/L20 A0..	
25	20	140	8	0.8	D 2110 R/L25 A0..	
32	25	170	8	0.8	D 2110 R/L32 A0..	

2111 Radiusstahl

	Abmessungen				Typ
	h [mm]	b [mm]	l [mm]	r [mm]	
10	10	90	4.0	D 2111/10 A0..	
12	12	100	4.0	D 2111/12 A0..	
16	16	110	4.0	D 2111/16 A0..	
20	20	125	4.0	D 2111/20 A0..	
25	20	140	4.0	D 2111/25 A0..	
32	32	170	4.0	D 2111/32 A0..	

2112 Schlichtstahl, gerade

	Abmessungen					Typ
	h [mm]	b [mm]	l [mm]	l1-0.2 [mm]	r [mm]	
10	10	90	8	0.4	D 2112 R/L10 A0..	
12	12	100	8	0.4	D 2112 R/L12 A0..	
16	16	110	8	0.8	D 2112 R/L16 A0..	
20	20	125	8	0.8	D 2112 R/L20 A0..	
25	20	140	8	0.8	D 2112 R/L25 A0..	
32	25	170	8	0.8	D 2112 R/L32 A0..	

2113 Messerstahl

	Abmessungen						Typ
	h [mm]	b [mm]	l [mm]	l1-0.2 [mm]	r [mm]	c [mm]	
10	10	90	8	0.2	4	D 2113 R/L10 A0..	
12	12	100	8	0.4	4	D 2113 R/L12 A0..	
16	16	110	8	0.8	4	D 2113 R/L16 A0..	
20	20	125	8	0.8	5	D 2113 R/L20 A0..	
25	20	140	8	0.8	5	D 2113 R/L25 A0..	
32	25	170	8	0.8	5	D 2113 R/L32 A0..	

Bestellinformationen

Verfügbare Ausführungen

Bestell-Code	DIAPACT(PKD)					CVD-Diam.	MKD	Naturdiam.
	A010	A020	A030	A040	A041	A060	A070	A080
Verfügbarkeit	✓	○	○	○	○	○	○	○
Weitere Infos	→ Seite 1-6					→ Seite 1-7		

✓ Auf Lager ○ Auf Anfrage, bitte Wunschtermin für die Lieferung angeben

Bestellbeispiel für:

Typ: D 2111/10 A0..
Ausführung: CVD-Diamant

- D 2111/10 A060
- tt.mm.jj (Wunschtermin)

Die Schneidkantenlänge l1 kann angegeben werden und sollte bei MKD- und Naturdiamant-Werkzeugen aus Kostengründen möglichst kurz gewählt werden.



Schaftwerkzeuge mit Diamant-Schneiden

- Für Aussenbearbeitung
- Anwendung Plan- und Längsdrehen

2114 Eckstahl

	Abmessungen						Typ
	h [mm]	b [mm]	l [mm]	l1-0.2 [mm]	r [mm]	c [mm]	
	10	10	90	8	0.2	4	D 2114 R/L10 A0..
	12	12	100	8	0.4	4	D 2114 R/L12 A0..
	16	16	110	8	0.8	4	D 2114 R/L16 A0..
	20	20	125	8	0.8	5	D 2114 R/L20 A0..
	25	20	140	8	0.8	5	D 2114 R/L25 A0..
	32	25	170	8	0.8	5	D 2114 R/L32 A0..

2117 Schlichtstahl, gebogen

	Abmessungen						Typ
	h [mm]	b [mm]	l [mm]	l1-0.2 [mm]	r [mm]	c [mm]	
	10	10	90	8	0.4	6	D 2117 R/L10 A0..
	12	12	100	8	0.4	6	D 2117 R/L12 A0..
	16	16	110	8	0.8	6	D 2117 R/L16 A0..
	20	20	125	8	0.8	6	D 2117 R/L20 A0..
	25	20	140	8	0.8	7	D 2117 R/L25 A0..
	32	25	170	8	0.8	7	D 2117 R/L32 A0..

Bestellinformationen

Verfügbare Ausführungen

Bestell-Code	DIAPACT(PKD)					CVD-Diam.	MKD	Naturdiam.
	A010	A020	A030	A040	A041	A060	A070	A080
Verfügbarkeit	✓	○	○	○	○	○	○	○
Weitere Infos	→ Seite 1-6					→ Seite 1-7		

✓ Auf Lager ○ Auf Anfrage, bitte Wunschtermin für die Lieferung angeben

Bestellbeispiel für:

Typ: D 2114 R/L10 A0..
Ausführung R: MKD

- D 2114 R10 A070
- tt.mm.jj (Wunschtermin)

Die Schneidkantenlänge l1 kann angegeben werden und sollte bei MKD- und Naturdiamant-Werkzeugen aus Kostengründen möglichst kurz gewählt werden.



Schaftwerkzeuge mit Diamant-Schneiden

Für Aussenbearbeitung | Anwendung Ein- und Abstechen

Schaftwerkzeuge mit Diamant-Schneiden

- Für Aussenbearbeitung
- Anwendung **Ein- und Abstechen**

2115 Einstechstahl

	Abmessungen					Typ
	h [mm]	b [mm]	l [mm]	l1-0.2 [mm]	t [mm]	
	10	10	90	bis 3.8	8	D 2115 R/L10 A0..
	12	12	100	bis 3.8	9	D 2115 R/L12 A0..
	16	16	110	bis 7.8	10	D 2115 R/L16 A0..
	20	20	125	3.8 – 7.8	12	D 2115 R/L20 A0..
	25	20	140	3.8 – 7.8	15	D 2115 R/L25 A0..

Bestellinformationen

Verfügbare Ausführungen

Bestell-Code	DIAPACT(PKD)					CVD-Diam.	MKD	Naturdiam.
	A010	A020	A030	A040	A041	A060	A070	A080
Verfügbarkeit	✓	○	○	○	○	○	○	○
Weitere Infos	→ Seite 1-6					→ Seite 1-7		

✓ Auf Lager ○ Auf Anfrage, bitte Wunschtermin für die Lieferung angeben

Bestellbeispiel für:

Typ: D 2115 R/L10 A0..
Ausführung L: MKD

- D 2115 L10 A070
- tt.mm.jj (Wunschtermin)
- Einstechbreite l1 [mm]¹⁾
- Einstechtiefe t [mm]

¹⁾ Die Schneidkantenlänge l1 sollte bei MKD- und Naturdiamant-Werkzeugen aus Kostengründen möglichst kurz gewählt werden.





Produktspektrum

Klemmhalter
Bohrstangen

→ Seite 1-57

→ Seite 1-66

Vorteile im Überblick

- Exakte Positionierung der Schneiden
- Schneller Wechsel der Schneiden
- Bei Bedarf mit Kühlmittelbohrungen

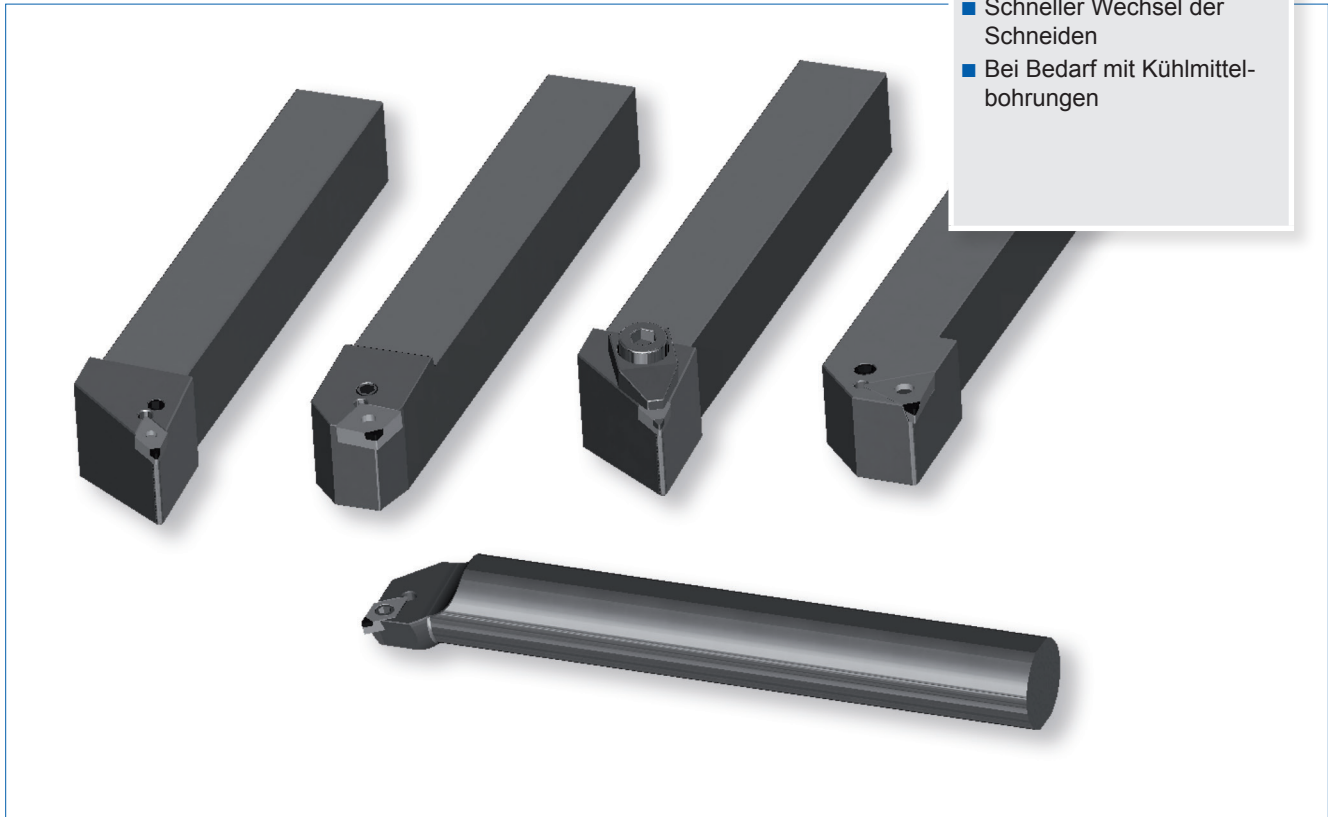

Produktmerkmale

- Durch die hohe Anzahl der verschiedensten Typen immer die richtige Auswahl der richtigen Werkzeugaufnahme.
- Aufnahmen aus Werkzeugstahl oder Hartmetall.
- Schneidenaufnahmen geschraubt oder geklemmt.
- Bohrstangen geschliffen.

Anwendungsbereiche

- Klemmhalter und Bohrstangen für die Innen- und Aussenbearbeitung.
- VHM-Bohrstangen für tiefe Bohrungen.
- Bohrstangen mit Kühlmittelbohrung für höchste Ansprüche und für höhere Standzeit der Schneiden.

Einsatzbedingungen

- Aufnahme möglichst kurz spannen, um Vibrationen zu vermeiden.
- Kontrolle der Schraubenverbindung vor dem Einsatz.
- Bei der Auswahl den grösstmöglichen Querschnitt wählen.
- Für tiefe Bohrungen VHM-Bohrstangen auswählen.



Klemmhalter mit Spannpratzenspannung

Typ MTENN

für WSP-Typ	Abmessungen					Typ
	h [mm]	b [mm]	l1 [mm]	l2 [mm]	f [mm]	
TN..16 04..	25	25	150	33	12.5	MTENN 2525 M 16
	32	25	170	33	12.5	MTENN 3225 P 16
	32	25	170	33	16	MTENN 3232 P 16

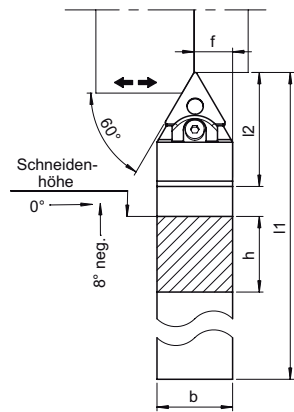

Bestellbeispiel

- Klemmhalter MTENN 2525 M 16



Klemmhalter mit Kniehebelspannung

Typ PCBNR/L

für WSP-Typ	Abmessungen					Typ
	h [mm]	b [mm]	l1 [mm]	l2 [mm]	f [mm]	
CNM. 12 04 ..	20	20	125	29	17	PCBNR/L 2020 K 12
	25	25	150	37	22	PCBNR/L 2525 M 12
	32	25	170	37	22	PCBNR/L 3225 P 12

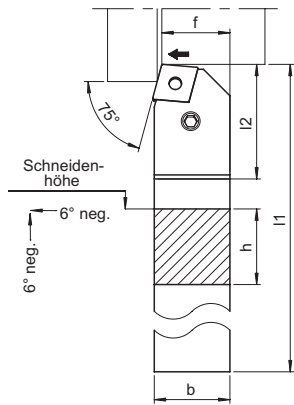

Typ PCLNR/L

für WSP-Typ	Abmessungen					Typ
	h [mm]	b [mm]	l1 [mm]	l2 [mm]	f [mm]	
CNM. 12 04 ..	16	16	100	26	20	PCLNR/L 1616 H 12
	20	20	125	28	25	PCLNR/L 2020 K 12
	25	25	150	33	32	PCLNR/L 2525 M 12
	32	25	170	33	32	PCLNR/L 3225 P 12

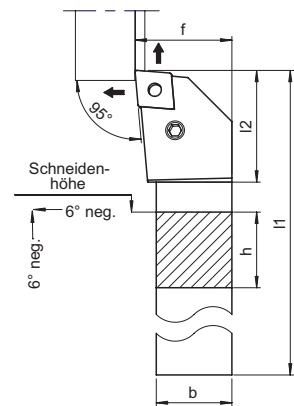

Typ PDJNR/L

für WSP-Typ	Abmessungen					Typ
	h [mm]	b [mm]	l1 [mm]	l2 [mm]	f [mm]	
DNM. 15 06 ..	20	20	125	35	25	PDJNR/L 2020 K 15
	25	25	150	39	32	PDJNR/L 2525 M 15
	32	25	170	33	32	PDJNR/L 3225 P 15
	32	32	170	39	40	PDJNR/L 3232 P 15
	40	25	200	39	32	PDJNR/L 4025 R 15

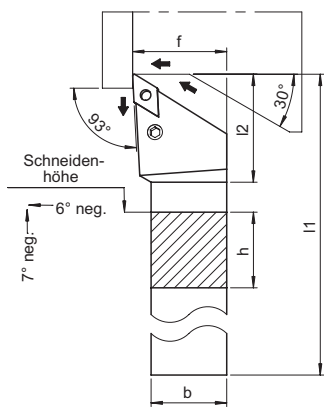

Fortsetzung und Bestellinformationen siehe nächste Seite



Typ PSSNR/L

für WSP-Typ	Abmessungen						Typ
	h [mm]	b [mm]	l1 [mm]	l2 [mm]	f [mm]	f1 [mm]	
SNM. 09 03 ..	16	16	100	17	20	14	PSSNR/L 1616 H 09
	20	20	125	22	25	19	PSSNR/L 2020 K 09
SNM. 12 04 ..	20	20	125	22	25	17	PSSNR/L 2020 K 12
	25	25	150	25	32	24	PSSNR/L 2525 M 12
	32	25	170	25	32	24	PSSNR/L 3225 P 12

Typ PTFNR/L

für WSP-Typ	Abmessungen					Typ
	h [mm]	b [mm]	l1 [mm]	l2 [mm]	f [mm]	
TNM. 11 03 ..	10	10	70	16	15	PTFNR/L 1010 E 11
	12	12	80	23	16	PTFNR/L 1212 F 11
	16	16	100	26	20	PTFNR/L 1616 H 11
TNM. 16 04 ..	16	16	100	26	20	PTFNR/L 1616 H 16
	20	20	125	28	25	PTFNR/L 2020 K 16
	25	25	150	33	32	PTFNR/L 2525 M 16

Typ PTGNR/L

für WSP-Typ	Abmessungen					Typ
	h [mm]	b [mm]	l1 [mm]	l2 [mm]	f [mm]	
TNM. 11 03 ..	10	10	70	16	12	PTGNR/L 1010 E 11
	12	12	80	23	16	PTGNR/L 1212 F 11
	16	16	100	26	20	PTGNR/L 1616 H 11
TNM. 16 04 ..	16	16	100	26	20	PTGNR/L 1616 H 16
	20	20	125	28	25	PTGNR/L 2020 K 16
	25	25	150	33	32	PTGNR/L 2525 M 16
	32	25	170	33	32	PTGNR/L 3225 P 16

Bestellbeispiel

■ Klemmhalter PSSNR 1616 H 09



Klemmhalter mit Schraubenspannung

Typ SCLCR/L

für WSP-Typ	Abmessungen					Typ
	h [mm]	b [mm]	l1 [mm]	l2 [mm]	f [mm]	
CC.. 06 02 ..	10	10	70	17	12	SCLCR/L 1010 E 06
	12	12	80	29	16	SCLCR/L 1212 F 09
	16	16	100	29	20	SCLCR/L 1616 H 09
CC.. 09 T3 ..	20	20	125	29	25	SCLCR/L 2020 K 09
	16	16	100	29	20	SCLCR/L 1616 H 12
CC.. 12 04 ..	20	20	125	29	25	SCLCR/L 2020 K 12
	25	25	150	33	32	SCLCR/L 2525 M 12

Typ SDJCR/L

für WSP-Typ	Abmessungen					Typ
	h [mm]	b [mm]	l1 [mm]	l2 [mm]	f [mm]	
DC.. 07 02 ..	10	10	70	17	12	SDJCR/L 1010 E 07
	12	12	80	17	16	SDJCR/L 1212 F 07
	16	16	100	17	20	SDJCR/L 1616 H 07
	20	20	125	17	25	SDJCR/L 2020 K 07
DC.. 11 T3 ..	12	12	80	29	16	SDJCR/L 1212 F 11
	16	16	100	29	20	SDJCR/L 1616 H 11
	20	20	125	29	25	SDJCR/L 2020 K 11
	25	25	150	33	32	SDJCR/L 2525 M 11

Typ SSDCN

für WSP-Typ	Abmessungen				Typ
	h [mm]	b [mm]	l1 [mm]	f [mm]	
SCM. 09 T3 ..	12	12	80	6	SSDCN 1212 F 09
	16	16	100	8	SSDCN 1616 H 09
	20	20	125	10	SSDCN 2020 K 09
SCM. 12 04 ..	16	16	100	8	SSDCN 1616 H 12
	20	20	125	10	SSDCN 2020 K 12
	25	25	150	12.5	SSDCN 2525 M 12

Fortsetzung siehe nächste Seite, Bestellinformationen → Seite 1-62



Typ STFCR/L

für WSP-Typ	Abmessungen					Typ
	h [mm]	b [mm]	l1 [mm]	l2 [mm]	f [mm]	
TCM. 09 02 ..	10	10	70	14	12	STFCR/L 1010 E 09
TCM. 11 02 ..	12	12	80	16	16	STFCR/L 1212 F 11
	16	16	100	16	20	STFCR/L 1616 H 11
TCM. 16 T3 ..	16	16	100	21	20	STFCR/L 1616 H 16
	20	20	125	21	32	STFCR/L 2020 K 16
	25	25	150	26	32	STFCR/L 2525 M 16

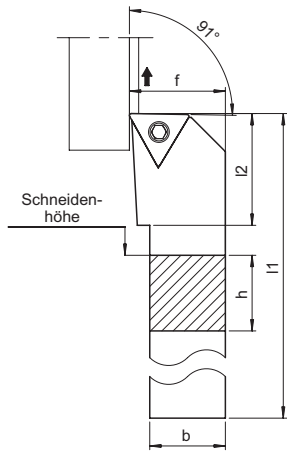

Typ STGCR/L

für WSP-Typ	Abmessungen					Typ
	h [mm]	b [mm]	l1 [mm]	l2 [mm]	f [mm]	
TCM. 09 02 ..	10	10	70	14	12	STGCR/L 1010 E 09
TCM. 11 02 ..	12	12	80	17	16	STGCR/L 1212 F 11
	16	16	100	17	20	STGCR/L 1616 H 11
TCM. 16 T3 ..	16	16	125	29	20	STGCR/L 1616 H 16
	20	20	150	29	25	STGCR/L 2020 K 16
	25	25	150	33	32	STGCR/L 2525 M 16

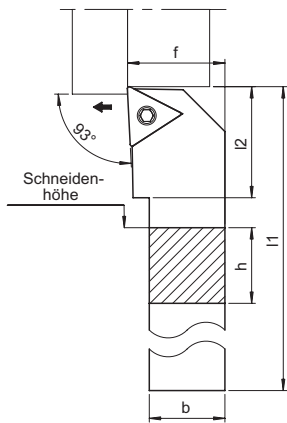

Typ SVJBR/L

für WSP-Typ	Abmessungen					Typ
	h [mm]	b [mm]	l1 [mm]	l2 [mm]	f [mm]	
VB.. 11 02 ..	12	12	80	29	16	SVJBR/L 1212 F 11
	16	16	100	29	20	SVJBR/L 1616 H 11
	20	20	125	29	25	SVJBR/L 2020 K 11
	25	25	150	29	32	SVJBR/L 2525 M 11
VB.. 16 04 ..	20	20	125	35	25	SVJBR/L 2020 K 16
	25	25	150	35	32	SVJBR/L 2525 M 16
	32	25	170	35	32	SVJBR/L 3225 P 16

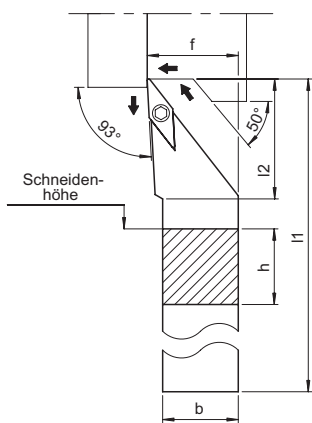

Fortsetzung und Bestellinformationen siehe nächste Seite



Klemmhalter

Mit Schraubenspannung

Typ SVJCR/L

für WSP-Typ	Abmessungen					Typ
	h [mm]	b [mm]	l1 [mm]	l2 [mm]	f [mm]	
VC.. 11 03 ..	10	10	70	23	12	SVJCR/L 1010 E 11
	12	12	80	23	16	SVJCR/L 1212 F 11
	16	16	100	23	20	SVJCR/L 1616 H 11
	20	20	125	23	25	SVJCR/L 2020 K 11
	25	25	150	26	32	SVJCR/L 2525 M 11
VC.. 16 04 ..	12	12	80	29	16	SVJCR/L 1212 F 16
	16	16	100	34	20	SVJCR/L 1616 H 16
	20	20	125	34	25	SVJCR/L 2020 K 16
	25	25	150	35	32	SVJCR/L 2525 M 16
	32	25	170	35	32	SVJCR/L 3225 P 16

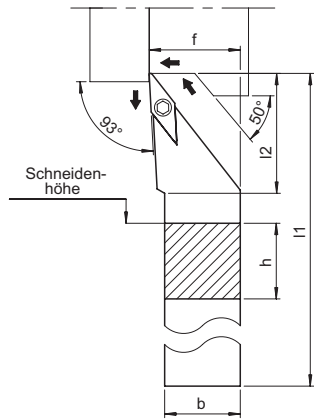

Typ SVVBN

für WSP-Typ	Abmessungen				Typ
	h [mm]	b [mm]	l1 [mm]	f [mm]	
VB.. 11 02 ..	12	12	80	6	SVVBN 1212 F 11
	16	16	100	8	SVVBN 1616 H 11
	20	20	125	10	SVVBN 2020 K 11
	25	25	150	12.5	SVVBN 2525 M 11
VB.. 16 04 ..	20	20	125	10	SVVBN 2020 K 16
	25	25	150	12.5	SVVBN 2525 M 16
	32	25	170	12.5	SVVBN 3225 P 16

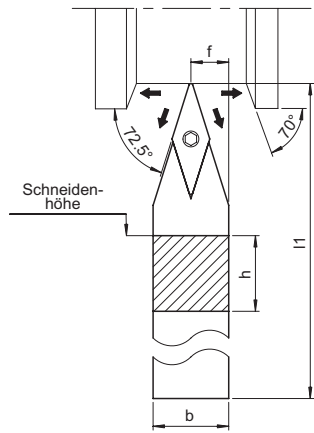

Typ SVVCN

für WSP-Typ	Abmessungen				Typ
	h [mm]	b [mm]	l1 [mm]	f [mm]	
VC.. 11 03 ..	12	12	80	6	SVVCN 1212 F 11
	16	16	100	8	SVVCN 1616 H 11
	20	20	125	10	SVVCN 2020 K 11
	25	25	150	12.5	SVVCN 2525 M 11
VC.. 16 04 ..	20	20	125	10	SVVCN 2020 K 16
	25	25	150	12.5	SVVCN 2525 M 16
	32	25	170	12.5	SVVCN 3225 P 16

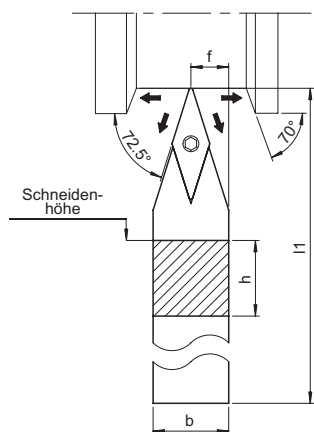

Bestellbeispiel

■ Klemmhalter SVJCR 1010 E 11



Klemmhalter für Innendrehstuhl 2125

Typ 2840

	passend zu Innendrehstuhl	Abmessungen						Typ
		Ød [mm]	l [mm]	l1 [mm]	ØD [mm]	□s [mm]	Øds [mm]	
	2125 R/L 4	4.0	100	20	22	16	18	2840-04
	2125 R/L 5	5.0	100	20	22	16	18	2840-05
	2125 R/L 6	6.0	100	20	22	16	18	2840-06
	2125 R/L 8	8.0	100	20	22	16	18	2840-08
	2125 R/L 10	10.0	120	25	26	20	22	2840-10
	2125 R/L 12	12.0	130	35	30	22	24	2840-12
	2125 R/L 16	16.0	150	40	40	29	32	2840-16

Bestellbeispiel

■ Klemmhalter 2840-06



Klemmhalter

Für Schältschneidplatte R 9.52

Klemmhalter für Schältschneidplatte R 9.52

Typ 2885

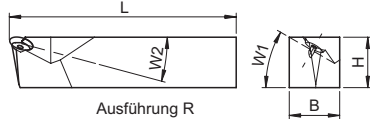
 Ausführung R	passend für Schneidplatte	Abmessungen					Typ
		H [mm]	B [mm]	L [mm]	W1	W2	
	2892-R 9.52	16	16	90	30°	15°	2885-16R/L
		20	20	90	30°	15°	2885-20R/L

Bestellbeispiel

■ Klemmhalter 2880-16R



Klemmhalter für Kollektorschneidplatte

Typ 2882

	Abmessungen						Typ
	passend für Schneidplatte	H [mm]	B [mm]	L [mm]	W1 [mm]	W2 [mm]	
	2896-T11	10	10	100	15°	44°	2882-10R/L

Typ 2884

	Abmessungen						Typ
	passend für Schneidplatte	H [mm]	B [mm]	L [mm]	W1 [mm]	W2 [mm]	
	2894-T06	10	10	100	15°	15°	2884-10R/L

Bestellbeispiel

■ Klemmhalter 2882-10R



Bohrstangen mit Kniehebelspannung

Typ PCLNR/L mit Kühlmittelzufuhr

für WSP-Typ	Abmessungen						Typ
	Ød [mm]	l1 [mm]	l2 [mm]	f [mm]	k°	ØD [mm]	
CNM. 12 04 ..	25	250	45	17	-12	32	A25S PCLNR/L 12
	32	250	50	22	-10	40	A32S PCLNR/L 12
	40	300	60	27	-10	50	A40T PCLNR/L 12

Typ PCLNR/L ohne Kühlmittelzufuhr

für WSP-Typ	Abmessungen						Typ
	Ød [mm]	l1 [mm]	l2 [mm]	f [mm]	k°	ØD [mm]	
CNM. 12 04 ..	25	300	45	17	-12	32	S25T PCLNR/L 12
	32	350	50	22	-10	40	S32U PCLNR/L 12
	40	400	60	27	-10	50	S40V PCLNR/L 12

Typ PDUNR/L mit Kühlmittelzufuhr

für WSP-Typ	Abmessungen						Typ
	Ød [mm]	l1 [mm]	l2 [mm]	f [mm]	k°	ØD [mm]	
DN.. 15 06 ..	32	250	60	22	-15	40	A32S PDUNR/L 15
	40	300	60	27	-12	50	A40T PDUNR/L 15
	50	300	70	35	-8	63	A50T PDUNR/L 15

Typ PDUNR/L ohne Kühlmittelzufuhr

für WSP-Typ	Abmessungen						Typ
	Ød [mm]	l1 [mm]	l2 [mm]	f [mm]	k°	ØD [mm]	
DN.. 15 06 ..	32	350	60	22	-15	40	S32U PDUNR/L 15
	40	400	60	27	-12	50	S40V PDUNR/L 15
	50	450	70	35	-8	63	S50W PDUNR/L 15

Fortsetzung und Bestellinformationen siehe nächste Seite



Typ PTFNR/L mit Kühlmittelzufuhr

für WSP-Typ	Abmessungen						ØD [mm]	Typ
	Ød [mm]	l1 [mm]	l2 [mm]	f [mm]	k°			
TN.. 11 03 ..	16	150	40	11	-14	20	A16M PTFNR/L 11	
	20	200	40	13	-12	25	A20R PTFNR/L 11	
TN.. 16 04 ..	25	250	45	17	-12	32	A25S PTFNR/L 16	
	32	250	60	22	-12	40	A32S PTFNR/L 16	

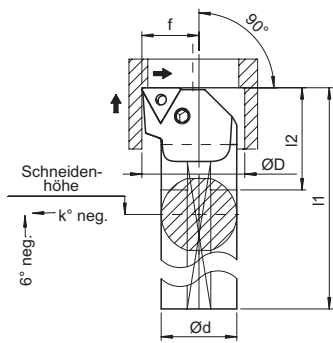

Typ PTFNR/L ohne Kühlmittelzufuhr

für WSP-Typ	Abmessungen						ØD [mm]	Typ
	Ød [mm]	l1 [mm]	l2 [mm]	f [mm]	k°			
TN.. 11 03 ..	16	200	40	11	-14	20	S16R PTFNR/L 11	
	20	250	40	13	-12	25	S20S PTFNR/L 11	
TN.. 16 04 ..	25	300	45	17	-12	32	S25T PTFNR/L 16	
	32	350	60	22	-12	40	S32U PTFNR/L 16	
	40	400	60	27	-8	50	S40V PTFNR/L 16	
	50	450	70	35	-8	63	S50W PTFNR/L 16	

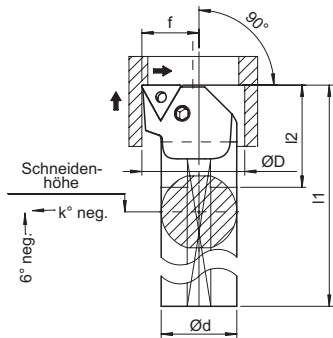

Bestellbeispiel

■ Bohrstange A32S PDUNR 15



S-Bohrstangen

Mit Schraubenspannung für Innenbearbeitung

S-Bohrstangen mit Schraubenspannung für Innenbearbeitung

Typ SCLCR/L mit Kühlmittelzufuhr

für WSP-Typ	Abmessungen						Typ
	Ød [mm]	l1 [mm]	l2 [mm]	f [mm]	k°	ØD [mm]	
CC.. 06 02 ..	12	125	30	9	-10	16	A12K SCLCR/L 06
CC.. 09 T3 ..	16	150	40	11	-10	20	A16M SCLCR/L 09
	20	200	40	13	-8	25	A20R SCLCR/L 09
	25	250	45	17	-5	32	A25S SCLCR/L 09
CC.. 12 04 ..	25	250	45	17	-5	32	A25S SCLCR/L 12

Typ SCLCR/L ohne Kühlmittelzufuhr

für WSP-Typ	Abmessungen						Typ
	Ød [mm]	l1 [mm]	l2 [mm]	f [mm]	k°	ØD [mm]	
CC.. 06 02 ..	8	100	50	6	-12	11	S08H SCLCR/L 06
	10	125	25	7	-10	13	S10K SCLCR/L 06
	12	150	30	9	-10	16	S12M SCLCR/L 06
	16	200	40	11	-10	20	S16R SCLCR/L 06
CC.. 09 T3 ..	16	200	40	11	-10	20	S16R SCLCR/L 09
	20	250	40	13	-8	25	S20S SCLCR/L 09
	25	300	45	17	-10	32	S25T SCLCR/L 09
CC.. 12 04 ..	25	300	50	17	-5	32	S25T SCLCR/L 12
	32	350	60	22	-5	40	S32U SCLCR/L 12
	40	400	60	27	-5	50	S40V SCLCR/L 12

Typ SDUCR/L mit Kühlmittelzufuhr

für WSP-Typ	Abmessungen						Typ
	Ød [mm]	l1 [mm]	l2 [mm]	f [mm]	k°	ØD [mm]	
DC.. 07 02 ..	12	125	25	9	-10	16	A12K SDUCR/L 07
	16	150	40	11	-10	20	A16M SDUCR/L 07
DC.. 11 T3 ..	20	200	40	13	-8	25	A20R SDUCR/L 11
	25	250	45	17	-5	32	A25S SDUCR/L 11

Typ SDUCR/L ohne Kühlmittelzufuhr

für WSP-Typ	Abmessungen						Typ
	Ød [mm]	l1 [mm]	l2 [mm]	f [mm]	k°	ØD [mm]	
DC.. 07 02 ..	10	125	25	7	-10	13	S10K SDUCR/L 07
	12	150	25	9	-10	16	S12M SDUCR/L 07
	16	200	40	11	-10	20	S16R SDUCR/L 07
DC.. 11 T3 ..	20	250	40	13	-8	25	S20S SDUCR/L 11
	25	300	45	17	-8	32	S25T SDUCR/L 11
	32	350	60	22	-5	40	S32U SDUCR/L 11

Fortsetzung siehe nächste Seite, Bestellinformationen → Seite 1-70



Typ SSKCR/L mit Kühlmittelzufuhr

für WSP-Typ	Abmessungen					ØD [mm]	Typ
	Ød [mm]	l1 [mm]	l2 [mm]	f [mm]	k°		
SC.. 09 T3 ..	16	150	35	11	-8	20	A16M SSKCR/L 09
	20	200	40	13	-8	25	A20R SSKCR/L 09
SC.. 12 04 ..	25	250	50	17	-5	32	A25S SSKCR/L 12

Typ SSKCR/L ohne Kühlmittelzufuhr

für WSP-Typ	Abmessungen					ØD [mm]	Typ
	Ød [mm]	l1 [mm]	l2 [mm]	f [mm]	k°		
SC.. 09 T3 ..	16	150	40	11	-8	20	S16R SSKCR/L 09
	20	200	40	13	-8	25	S20S SSKCR/L 09
SC.. 12 04 ..	25	250	50	17	-5	32	S25T SSKCR/L 12

Typ STFCR/L mit Kühlmittelzufuhr

für WSP-Typ	Abmessungen					ØD [mm]	Typ
	Ød [mm]	l1 [mm]	l2 [mm]	f [mm]	k°		
TC.. 11 02 ..	12	125	30	9	-10	16	A12K STFCR/L 11
	16	150	35	11	-8	20	A16M STFCR/L 11
TC.. 16 T3 ..	20	200	45	13	-8	25	A20R STFCR/L 16
	25	250	50	17	-5	32	A25S STFCR/L 16

Fortsetzung und Bestellinformationen siehe nächste Seite



S-Bohrstangen

Mit Schraubenspannung für Innenbearbeitung

Typ STFCR/L ohne Kühlmittelzufuhr

für WSP-Typ	Abmessungen						ØD [mm]	Typ
	Ød [mm]	l1 [mm]	l2 [mm]	f [mm]	k°			
TC.. 09 02 ..	8	100	25	6	-15	11	S08H STFCR/L 09	
	10	125	25	7	-12	13	S10K STFCR/L 09	
	12	150	30	9	-10	16	S12M STFCR/L 09	
TC.. 11 02 ..	10	125	28	7	-12	13	S10K STFCR/L 11	
	12	150	30	9	-10	16	S12M STFCR/L 11	
	16	200	40	11	-8	20	S16R STFCR/L 11	
	20	250	40	13	-8	25	S20S STFCR/L 11	
TC.. 16 T3 ..	20	250	45	13	-8	25	S20S STFCR/L 16	
	25	300	50	17	-5	32	S25T STFCR/L 16	
	32	350	50	22	-5	40	S32U STFCR/L 16	
	40	400	60	27	-5	50	S40V STFCR/L 16	

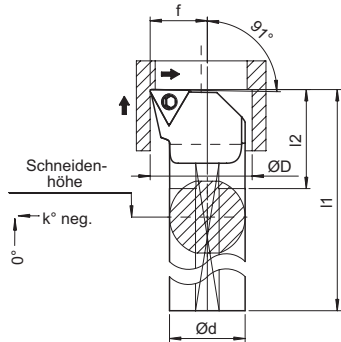

Bestellbeispiel

■ S-Bohrstange S08H STFCR 09



VHM-Bohrstangen mit Schraubenspannung für Innenbearbeitung

■ Mit Innenkühlung

Typ SCLCR/L mit Kühlmittelzufuhr

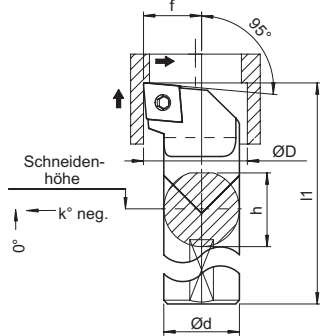

für WSP-Typ	Abmessungen						Typ
	Ød [mm]	l1 [mm]	f [mm]	h [mm]	k°	ØD [mm]	
CC.. 06 02 ..	8	125	9	7.5	-12	11	E08K SCLCR/L 06
	10	150	7	9.5	-10	13	E10M SCLCR/L 06
	12	180	9	11.5	-10	16	E12Q SCLCR/L 06
CC.. 09 T3 ..	16	200	11	15.5	-10	20	E16R SCLCR/L 09
	20	250	13	19.5	-8	25	E20S SCLCR/L 09
	25	300	17	24	-5	32	E25T SCLCR/L 09

Typ SDQCR/L mit Kühlmittelzufuhr

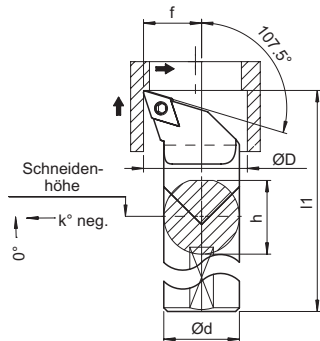

für WSP-Typ	Abmessungen						Typ
	Ød [mm]	l1 [mm]	f [mm]	h [mm]	k°	ØD [mm]	
DC.. 07 02 ..	10	150	7	9.5	-10	13	E10M SDQCR/L 07
	12	180	9	11.5	-10	16	E12Q SDQCR/L 07
	16	200	11	15.5	-10	20	E16R SDQCR/L 07
DC.. 11 T3 ..	20	250	13	19.5	-8	25	E20S SDQCR/L 11
	25	300	17	24	-5	32	E25T SDQCR/L 11

Typ SDUCR/L mit Kühlmittelzufuhr

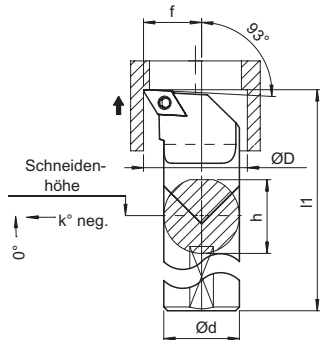

für WSP-Typ	Abmessungen						Typ
	Ød [mm]	l1 [mm]	f [mm]	h [mm]	k°	ØD [mm]	
DC.. 07 02 ..	10	150	7	9.5	-10	13	E10M SDUCR/L 07
	12	180	9	11.5	-10	16	E12Q SDUCR/L 07
	16	200	11	15.5	-10	20	E16R SDUCR/L 07
DC.. 11 T3 ..	20	250	13	19.5	-8	25	E20S SDUCR/L 11
	25	300	17	24	-5	32	E25T SDUCR/L 11

Fortsetzung und Bestellinformationen siehe nächste Seite



VHM-Bohrstangen

Mit Schraubenspannung für Innenbearbeitung

Typ STFCR/L mit Kühlmittelzufuhr

für WSP-Typ	Abmessungen						ØD [mm]	Typ
	Ød [mm]	l1 [mm]	f [mm]	h [mm]	k°			
TC.. 09 02 ..	10	150	7	9.5	-12	13	E10M STFCR/L 09	
	12	180	9	11.5	-10	16	E12Q STFCR/L 09	
TC.. 11 02 ..	16	200	11	15.5	-8	20	E16R STFCR/L 11	
TC.. 16 T3 ..	20	250	13	19.5	-8	25	E20S STFCR/L 16	
	25	300	17	24	-5	32	E25T STFCR/L 16	

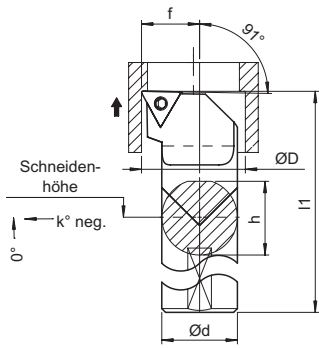

Bestellbeispiel

- VHM-Bohrstange E10M STFCR 09



Bohrstangen für Bohrstangeneinsatz 2870 Typ A und B

Typ 2855

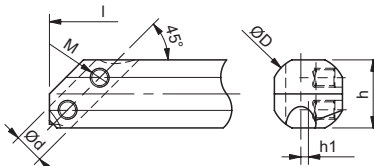

passend für Bohrstangeneinsatz	Abmessungen						Typ
	ØD [mm]	h [mm]	l [mm]	h1 [mm]	M [mm]	Ød [mm]	
2870-8 A+B	20	18	200	2	5	8	2855-20
2870-10 A+B	25	22	250	3	6	10	2855-25
2870-12 A+B	32	28	300	4	8	12	2855-32
2870-14 A+B	40	36	350	5	8	14	2855-40
2870-16 A+B	50	45	400	6	8	16	2855-50

Bestellbeispiel

■ Bohrstange 2855-20



Produktübersicht

Presspolierdiamant

→ Seite 1-75

Vorteile im Überblick

- Ersetzt Schleifen und Polieren
- Erzeugt sehr glatte Oberfläche
- Austauschbarer Diamant-Einsatz
- Einfache Handhabung

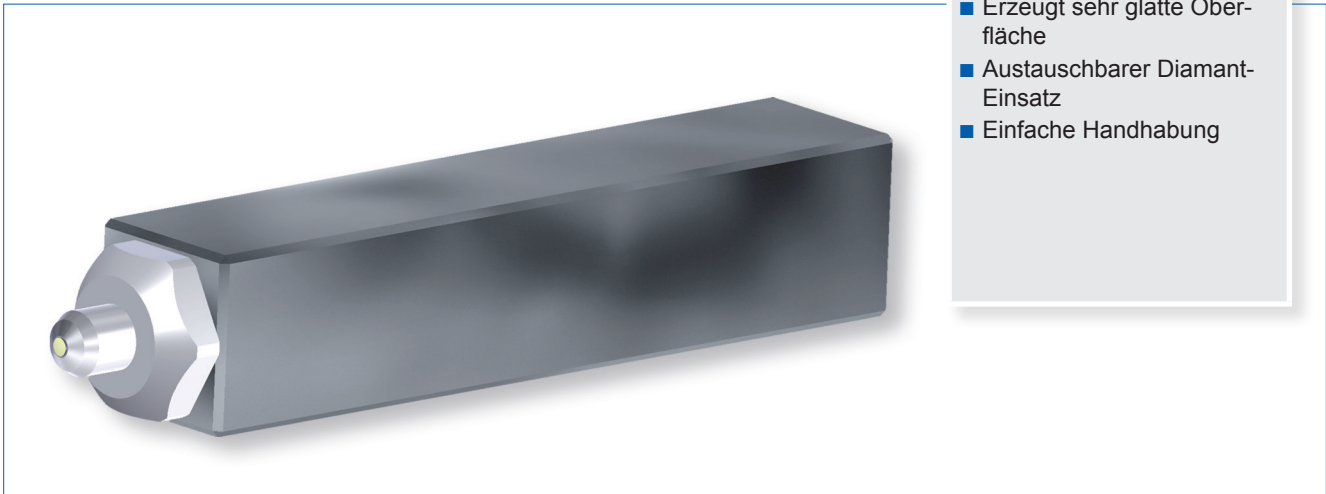

Allgemeines zu Presspolierdiamanten

Der Presspolierdiamant ist mit einem speziellen Diamanten bestückt, mit dem Oberflächen der meisten metallischen Materialien nach einem Vordrehen poliert werden können. Es werden Oberflächengüten von $Ra < 0.4 \mu m$ erzeugt. Auch Gusseisen und weiche Metalle (Bronze, Kupfer etc.) können poliert werden.

Vorbereitung des Werkstückes

Vor dem Einsatz des Presspolierdiamanten sollte die zu polierende Oberfläche einen Ra-Wert von ca. $1.6 \mu m$ aufweisen.

Das Dreh-Ist-Mass sollte an der oberen Grenze des Toleranzfeldes liegen.

Bedienungshinweise

Die Bedienungshinweise werden mit dem Werkzeug mitgeliefert.

Einsatzparameter

Umlaufgeschwindigkeit: $V = 90 \text{ m/min}$
Vorschub: $s = 0.1 \text{ mm/U}$

Kühlmittel

Der Einsatz von Kühlmittel ist empfehlenswert. Es bestehen keine besonderen Anforderungen. Wasser oder Öl.



Presspolierdiamant und Halter

Presspolierdiamant

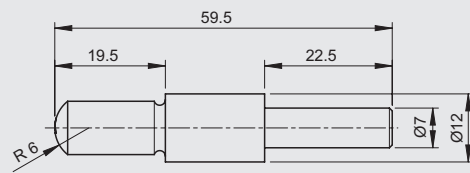

Masse in mm

Typ

Presspolierdiamant 2886

Halter

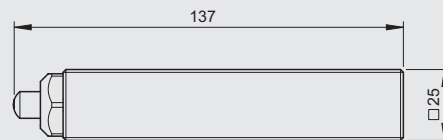

Masse in mm

Typ

Presspolier-Halter 2887

Bestellbeispiel

- Presspolierdiamant 2886
- Presspolier-Halter 2887



Produktübersicht

DIAPACT(PKD)-Kollektor-Schäldrehwerkzeug
DIAPACT(PKD)-Kollektor-Schälschneidplatten
DIAPACT(PKD)-Kollektor-Drehwerkzeug

→ Seite 1-77

→ Seite 1-77

→ Seite 1-78

Vorteile im Überblick

- Hohe Oberflächengüten
- Kontrollierte Rautiefen
- Kontrollierte Spanlenkung
- Geringe Gratbildung

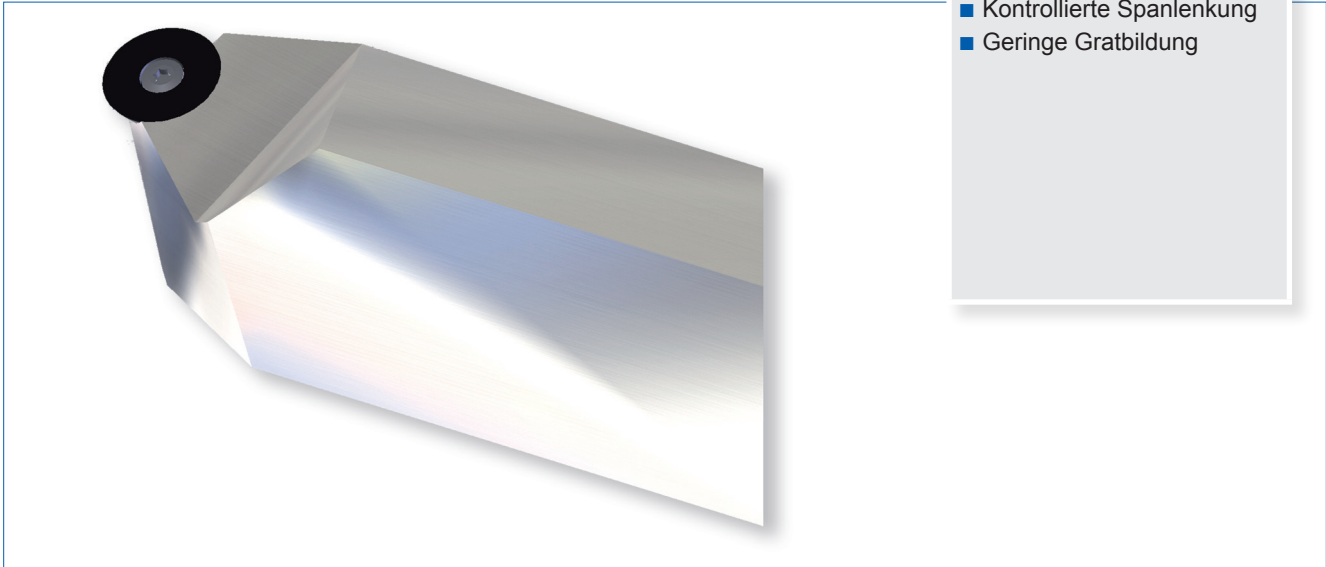

Anwendungsbereich

Überdrehen der Kommutatoren aus Kupfer-Lamellen

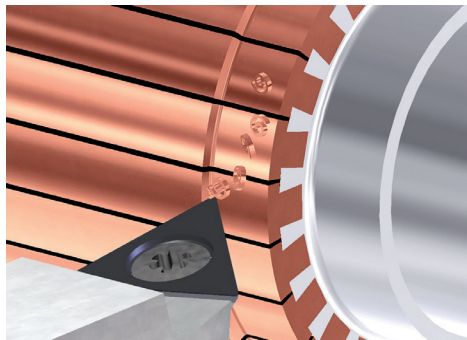

Einsatzbedingungen

- Werkzeuge nicht mechanisch vermessen (Ausbruchgefahr).
- Stabile Aufspannung der Werkzeuge.
- Exakte Einstellung der Spitzenhöhe.
- Die folgenden Einsatzparameter sind stark abhängig von den geforderten Rautiefen:
 - Schnittgeschwindigkeit: 250 m/min – 400 m/min
 - Vorschub: 0.02 mm/U – 0.06 mm/U
 - Schnitttiefe: 0.10 mm – 0.30 mm



DIAPACT(PKD)-Kollektor-Schäldrehwerkzeug und -Schälschneidplatten

- Für Oberflächen mit geringer bis kleinster Rautiefe (Rt ca. 4µ bis unter 1µ) und geringer Gratbildung

DIAPACT(PKD)-Kollektor-Schäldrehwerkzeug

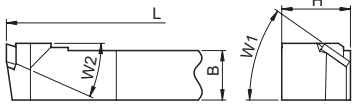
	Abmessungen					Typ
	H [mm]	B [mm]	L [mm]	W1	W2	
	20	14.4	100	35°	20°	2890-20 R/L

DIAPACT(PKD)-Kollektor-Schälschneidplatte passend zu Aufnahme 2880 .. R/L

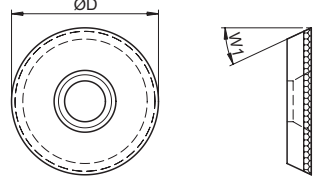
	Abmessungen			Typ
	passend zu Aufnahme	ØD [mm]	W1	
	2885 .. R/L	9.52	25°	2892-R9.52

DIAPACT(PKD)-Kollektor-Schälschneidplatten passend zu Aufnahme 288x-10 R/L

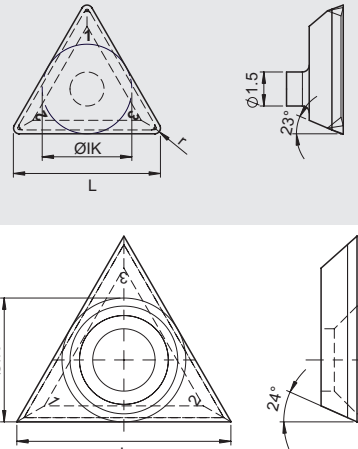
	passend zu Aufnahme	Abmessungen			Typ
		L [mm]	ØIK [mm]	r [mm]	
	2884-10 R/L	6.8	3.95	0.25	2894-T06
	2882-10 R/L	11	6.55	0.25	2896-T11

Bestellbeispiel

- DIAPACT(PKD)-Kollektor-Schälschneidplatte, Typ 2892-R9.52



Sonderwerkzeuge

DIAPACT(PKD)-Kollektor-Drehwerkzeug

DIAPACT(PKD)-Kollektor-Drehwerkzeug

- Für kontrollierte Rautiefen (je nach Vorschub) und kontrollierter Spanlenkung zur Vermeidung von Gratbildung und Oberflächenbeschädigungen

DIAPACT(PKD)-Kollektor-Drehwerkzeug

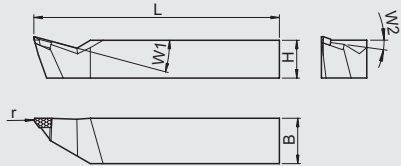
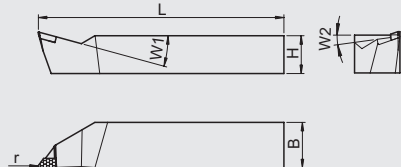
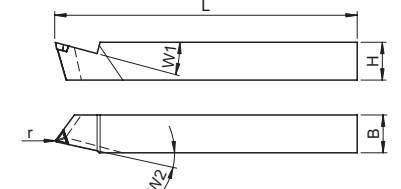
	Abmessungen						Typ
	H [mm]	B [mm]	L [mm]	W1	W2	r [mm]	
 <p>2900 L</p>	10	12	65	15°	8°	0.2	2900 R/L
 <p>2900 R</p>							
	10	10	100	15°	35°	0.3	2902 R/L

Bestellbeispiel

- DIAPACT(PKD)-Kollektor-Drehwerkzeug, Typ 2900 R





Produktübersicht

Naturdiamant- und MKD- Werkzeuge

→ Seite 1-81

Vorteile im Überblick

- höchste Standzeit
- beste Oberflächengüten (Rt-Werte von 0.01µm erreichbar)



Produkteigenschaften

- beste Diamantqualitäten
- Diamanten eingebettet und geklemmt oder Vakuumgelötet

Anwendungsbereiche

Allgemein für Hochglanzbearbeitung und feinste Oberflächengüten von Materialien wie z.B. Gold, Platin, Plexiglas, Aluminium. Bei nicht stark verschleissend wirkenden Werk-

stoffen sind Standzeiten von vielen Monaten im Dauereinsatz möglich.

Empfohlene Schnittbedingungen

Schnittgeschwindigkeit: $v =$ bis 1500 m/min. und darüber

Schnitttiefe maximal: $a =$ Schneidkantenlänge abzüglich 0.5mm

Vorschub: $s =$ je nach gewünschter Oberfläche zwischen 0.01 – 0.4 mm

Einsatzbedingungen

Maschine

Gute Lager und Führungen und ein erschütterungsfreier Lauf der Maschine sind die Voraussetzungen für eine saubere und feine Oberfläche, für exakte geometrische Formen und für eine hohe Standzeit der Diamant-Schneide.

Kühlung

Bei metallischen Werkstoffen wenn möglich kühlen. Ohne Kühlmittel muss die Schnittgeschwindigkeit reduziert werden. Nebelkühlung ist besonders vorteilhaft.

Behandlung

Diamant ist sehr hart, aber auch sehr spröde. Jeder Stoss und Schlag ist deshalb unbedingt zu vermeiden. Diamant-Werkzeuge nur in den mitgelieferten Verpackungen aufbewahren und nicht mit anderen Werkzeugen in Berührung bringen.



Naturdiamant- und MKD-Werkzeuge

Nr.2311



Typ

Nr. 2311

Nr.2312 L

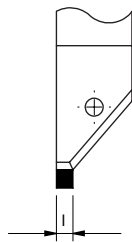

Typ

Nr. 2312 L

Nr.2312 R

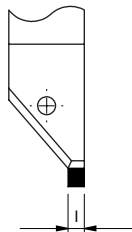

Typ

Nr. 2312 R

Nr.2313 L

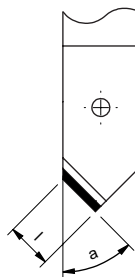

Typ

Nr. 2313 L

Nr.2313 R

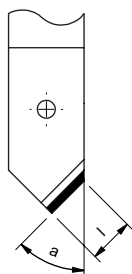

Typ

Nr. 2313 R

Fortsetzung siehe nächste Seite, Bestellinformationen → Seite 1-86



Naturdiamant- und MKD-Werkzeuge

Nr.2321

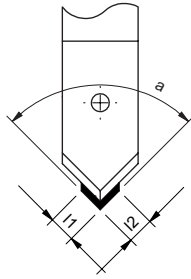

Typ

Nr. 2321

Nr.2322 L

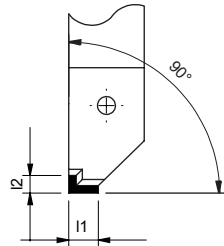

Typ

Nr. 2322 L

Nr.2322 R

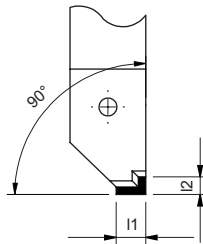

Typ

Nr. 2322 R

Nr.2323 L

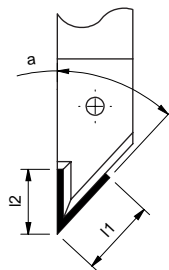

Typ

Nr. 2323 L

Nr.2323 R

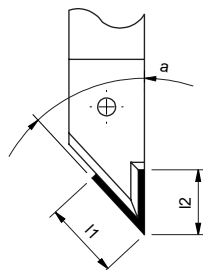

Typ

Nr. 2323 R

Fortsetzung siehe nächste Seite, Bestellinformationen → Seite 1-86



Naturdiamant- und MKD-Werkzeuge

Nr.2324 L

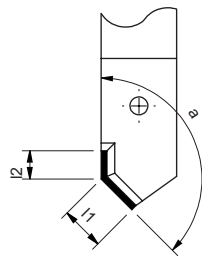

Typ

Nr. 2324 L

Nr.2324 R

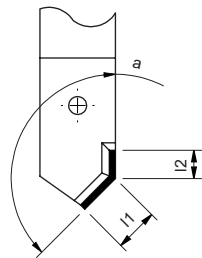

Typ

Nr. 2324 R

Nr.2325 L

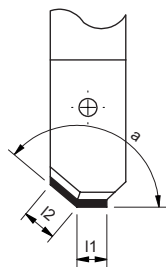

Typ

Nr. 2325 L

Nr.2325 R

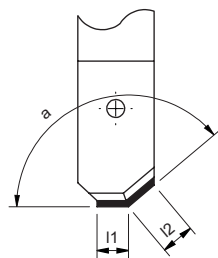

Typ

Nr. 2325 R

Nr.2326 L

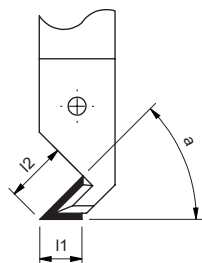

Typ

Nr. 2326 L

Fortsetzung siehe nächste Seite, Bestellinformationen → Seite 1-86



Naturdiamant- und MKD-Werkzeuge

Nr.2326 R

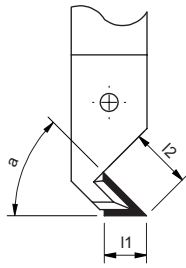

Typ

Nr. 2326 R

Nr.2331

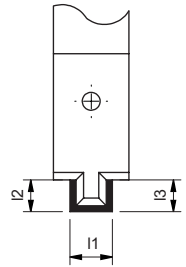

Typ

Nr. 2331

Nr.2332

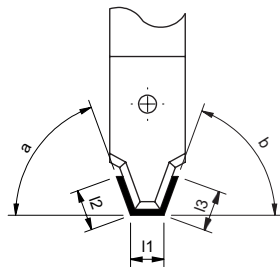

Typ

Nr. 2332

Nr.2333

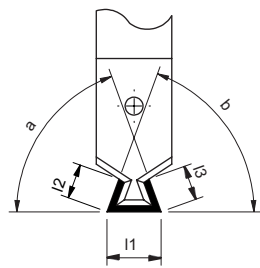

Typ

Nr. 2333

Nr.2334 L

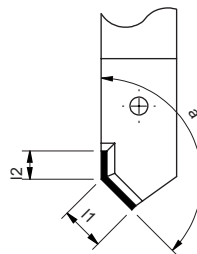

Typ

Nr. 2334 L

Fortsetzung siehe nächste Seite, Bestellinformationen → Seite 1-86



Naturdiamant- und MKD-Werkzeuge

Nr.2334 R

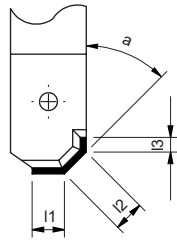

Typ
Nr. 2334 R

konkav



Typ
konkav

konvex

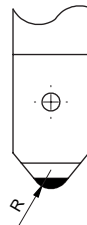

Typ
konvex

Satinee

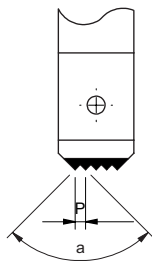

Typ
Satinee

Fortsetzung siehe nächste Seite, Bestellinformationen → Seite 1-86



Naturdiamant- und MKD-Werkzeuge

Transport (Santra)

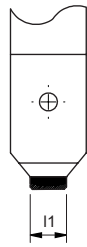

Typ

Transport (Santra)

Bestellinformationen

Verfügbare Ausführungen

	MKD	Naturdiamant
Bestell-Code	A070	A080
Verfügbarkeit	<input type="radio"/>	<input type="radio"/>

Auf Anfrage, bitte Wunschtermin für die Lieferung angeben

Bestellbeispiel für:

Typ: 2331
Ausführung: A070

- Nr. 2331 A070
- l1=2
- l2 +l3 =3
- Schaft 10x10x100
- tt.mm.jj (Wunschtermin)

Andere Ausführungen auf Anfrage





Produktspektrum

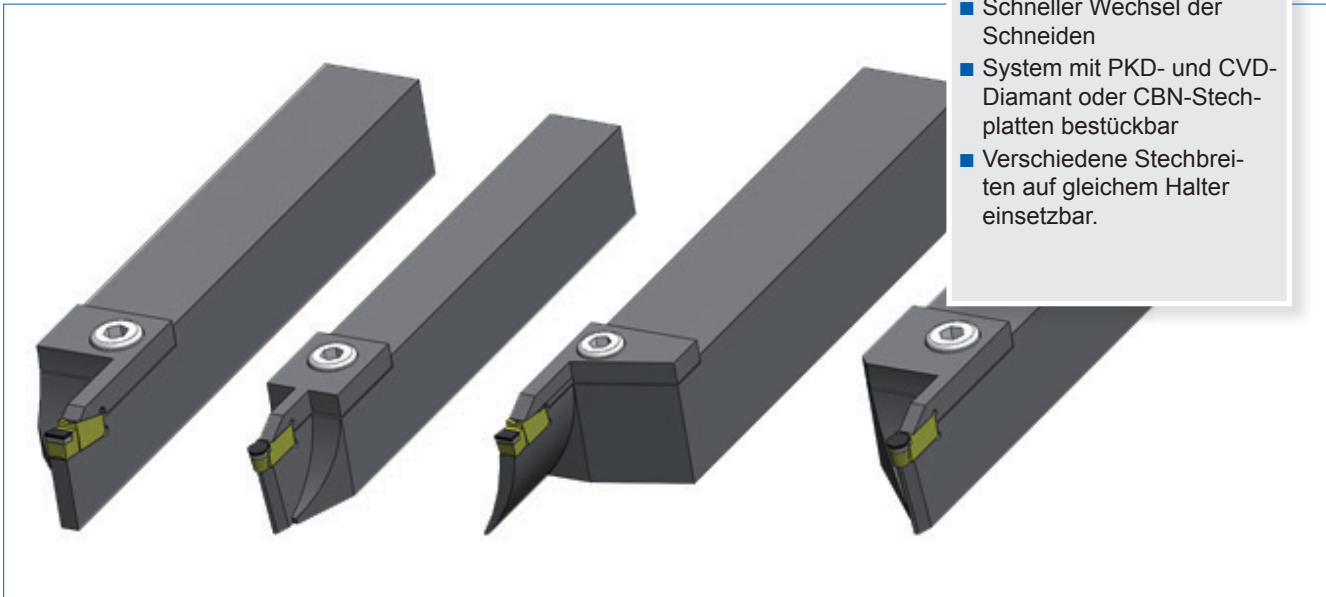

Vorteile im Überblick

- Exakte Positionierung der Schneiden
- Schneller Wechsel der Schneiden
- System mit PKD- und CVD-Diamant oder CBN-Stechplatten bestückbar
- Verschiedene Stechbreiten auf gleichem Halter einsetzbar.

Produktmerkmale

- BORAPACT(CBN)- oder Diamant-Rohlinge hart- oder vakuumgelötet auf HM-Grundkörpern
- Formen gemäss DIN oder nach Herstellerangaben
- CBN- und Diamant-Sorten je nach Anwendung unterschiedlich

Anwendungsbereiche

- Radiales und axiales Einstechen und Kopieren
- Abstechen

Einsatzbedingungen

- Aufnahmen möglichst kurz spannen, um Vibrationen zu vermeiden
- Kontrolle der Schraubenverbindung vor dem Einsatz



Klemmhalter R/L für Aussenabstechen und Einstechen

■ Für Aussenbearbeitung

GLCCR/L für Stechplatten LCMX 03050..FN/R/L A/B0..

	Abmessungen					Typ
	h=h1 [mm]	b [mm]	L [mm]	l1 [mm]	t [mm]	
	20	20	130	1.0-2.7	max. 4.9	GLCCR 2020 K 2.65
	20	20	130	1.0-2.7	max. 4.9	GLCCL 2020 K 2.65
	25	20	150	1.0-2.7	max. 4.9	GLCCR 2525 M 2.65
	25	20	150	1.0-2.7	max. 4.9	GLCCL 2525 M 2.65

GLCCR/L für Stechplatten LCMX 04050..FN/R/L A/B0..

	Abmessungen					Typ
	h=h1 [mm]	b [mm]	L [mm]	l1 [mm]	t [mm]	
	20	20	130	2.71-5.0	max. 4.9	GLCCR 2020 K 4.15
	20	20	130			GLCCL 2020 K 4.15
	25	25	150			GLCCR 2525 K 4.15
	25	25	150			GLCCL 2525 K 4.15

Klemmhalter L für Stirneinstiche

GLXCL für Stechplatten LCMX 03050 FN/R/L A/B0..

	Abmessungen							Typ
	h=h1 [mm]	b [mm]	L [mm]	l2 [mm]	l1 [mm]	Dmin. [mm]	Dmax. [mm]	
	25	25	150	20	3.0-3.99	50	65	GLXCL 2525-50 M 2.65
						60	85	GLXCL 2525-60 M 2.65
						80	110	GLXCL 2525-80 M 2.65
						100	160	GLXCL 2525-100 M 2.65
						150	250	GLXCL 2525-150 M 2.65

GLXCL für Stechplatten LCMX 04050 FN/R/L A/B0..

	Abmessungen							Typ
	h=h1 [mm]	b [mm]	L [mm]	l2 [mm]	l1 [mm]	Dmin. [mm]	Dmax. [mm]	
	25	25	150	25	4.0-5.0	60	100	GLXCL 2525-60 M 4.15
						100	200	GLXCL 2525-100 M 4.15
						200	700	GLXCL 2525-200 M 4.15

Bestellinformationen

■ Klemmhalter GLCCR 2020 K 4.15



Klemmhalter R/L für Kopierdrehen

- Für Aussenbearbeitung

GLDC R/L für Stechplatten LCMX 0305MO F A/B0..

h=h1 [mm]	b [mm]	L [mm]	Abmessungen		Dmax.	Typ
			l1 [mm]			
20	20	130	3.0-3.99		30	GLDCR 2020 K 03
20	20	130				GLDCL 2020 K 03
25	25	150				GLDCR 2525 M 03
25	25	150				GLDCL 2525 M 03

GLDC R/L für Stechplatten LCMX 0405MO F A/B0..

h=h1 [mm]	b [mm]	L [mm]	Abmessungen		Dmax.	Typ
			l1 [mm]			
20	20	130	4.0-4.99		40	GLDCR 2020 K 04
20	20	130				GLDCL 2020 K 04
25	25	150				GLDCR 2525 M 04
25	25	150				GLDCL 2525 M 04

GLDC R/L für Stechplatten LCMX 0505MO F A/B0..

h=h1 [mm]	b [mm]	L [mm]	Abmessungen		Dmax.	Typ
			l1 [mm]			
25	25	150	5.0-6.0		50	GLDCR 2525 M 05
25	25	150				GLDCL 2525 M 05

Bestellinformationen

- Klemmhalter GLCCR 2020 K 4.15



Klemmhalter mittig für Kopierdrehen

- Für Aussenbearbeitung

GLDCN für Stechplatten LCMX 0305MO F A/B0..

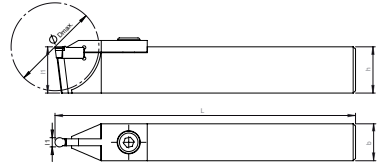
	Abmessungen				Dmax.	Typ
	h=h1 [mm]	b [mm]	L [mm]	l1 [mm]		
	20	16	130	3.0-3.99	30	GLDCN 2016 K03
	25	20	150			GLDCN 2520 M03

GLDCN für Stechplatten LCMX 0405MO F A/B0..

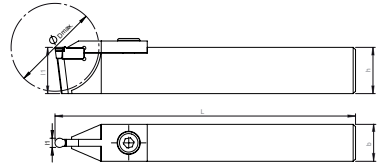
	Abmessungen				Dmax.	Typ
	h=h1 [mm]	b [mm]	L [mm]	l1 [mm]		
	20	16	130	3.0-3.99	30	GLDCN 2016 K04
	25	20	150			GLDCN 2520 M04

GLDCN für Stechplatten LCMX 0505MO F A/B0..

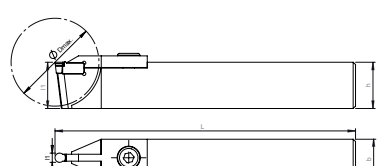
	Abmessungen				Dmax.	Typ
	h=h1 [mm]	b [mm]	L [mm]	l1 [mm]		
	25	20	150	5.0-6.0	50	GLDCN 2520 M05

Bestellinformationen

- Klemmhalter GLCCR 2020 K 4.15



Produktspektrum

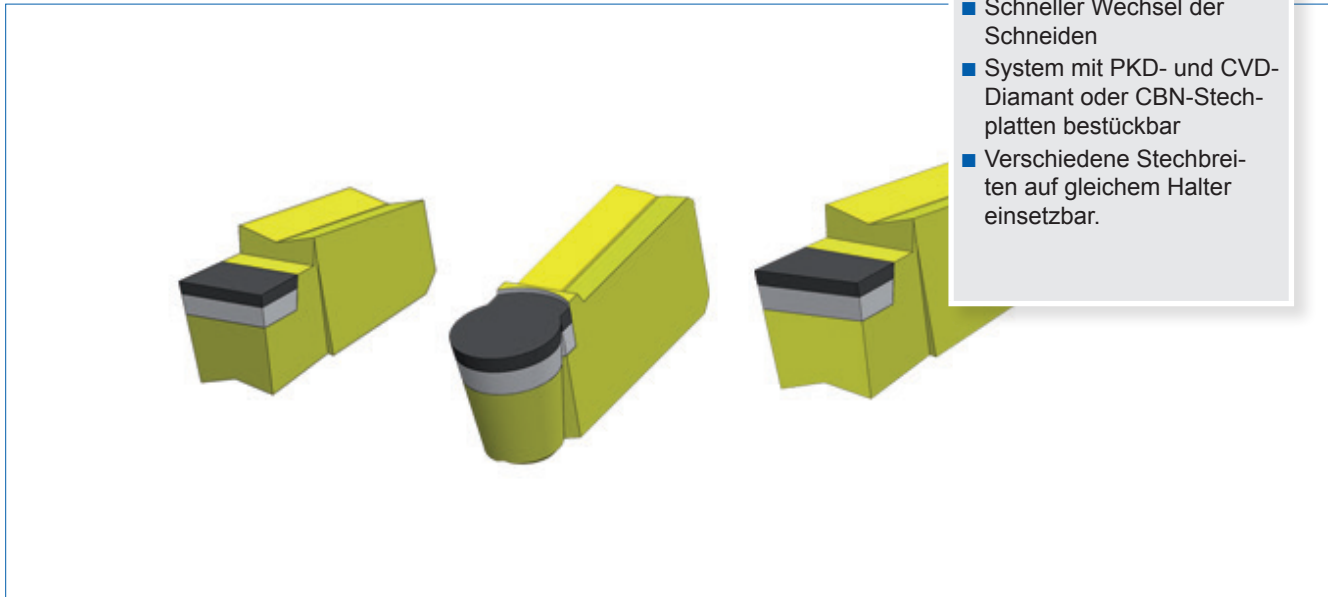

Vorteile im Überblick

- Exakte Positionierung der Schneiden
- Schneller Wechsel der Schneiden
- System mit PKD- und CVD-Diamant oder CBN-Stechplatten bestückbar
- Verschiedene Stechbreiten auf gleichem Halter einsetzbar.

Produktmerkmale

- BORAPACT(CBN)- oder Diamant-Rohlinge hart- oder vakuumgelötet auf HM-Grundkörpern
- Formen gemäss DIN oder nach Herstellerangaben
- CBN- und Diamant-Sorten je nach Anwendung unterschiedlich

Anwendungsbereiche

- Radiales und axiales Einstechen und Kopieren
- Abstechen
- Stechbreite frei wählbar

Einsatzbedingungen

- Aufnahmen möglichst kurz spannen, um Vibrationen zu vermeiden
- Kontrolle der Schraubenverbindung vor dem Einsatz



BORAPACT (CBN) Ab-, Ein- und Kopierstechplatten

■ Für Ab- und Einstechen

LCMX N/R/L

Abmessungen	Abmessungen					Typ
	l1 [mm]	t max [mm]	h [mm]	l [mm]	b [mm]	
1.0-2.7	4.9	5	13.5	2.7	LCMX 030502 FN B0..	
2.71-5.0					LCMX 040502 FN B0..	
1.0-2.7					LCMX 030502 FR B0..	
2.71-5.0					LCMX 040502 FR B0..	
1.0-2.7					LCMX 030502 FL B0..	
2.71-5.0					LCMX 040502 FL B0..	

■ Für Kopierstechen

LCMXMOEN

Abmessungen	Abmessungen			Typ
	ØD [mm]	b [mm]	l [mm]	
3.0 - 3.99	2.2	12.2	LCMX 0305MOEN F B0..	
4.0 - 4.99	3.0	12.6	LCMX 0405MOEN F B0..	
5.0 - 6.0	4.0	13.1	LCMX 0505MOEN F B0..	

DIAPACT (PKD) Ab-, Ein- und Kopierstechplatten

■ Für Ab- und Einstechen

LCMX N/R/L

Abmessungen	Abmessungen					Typ
	l1 [mm]	t max [mm]	h [mm]	l [mm]	b [mm]	
1.0-2.7	4.9	5	13.5	2.7	LCMX 030502 FN A0..	
2.71-5.0					LCMX 040502 FN A0..	
1.0-2.7					LCMX 030502 FR A0..	
2.71-5.0					LCMX 040502 FR A0..	
1.0-2.7					LCMX 030502 FL A0..	
2.71-5.0					LCMX 040502 FL A0..	

■ Für Kopierstechen

LCMXMOEN

Abmessungen	Abmessungen			Typ
	ØD [mm]	b [mm]	l [mm]	
3.0 - 3.99	2.2	12.2	LCMX 0305MOEN F A0..	
4.0 - 4.99	3.0	12.6	LCMX 0405MOEN F A0..	
5.0 - 6.0	4.0	13.1	LCMX 0505MOEN F A0..	

Bestellinformationen

Verfügbare Ausführungen

	BORAPACT(CBN)		DIAPACT(PKD)			CVD-Diamant
	B010	B020	A030	A040	A041	A060
Bestell-Code						
Verfügbarkeit	○	○	○	○	○	○
Weitere Infos	→ Seite 1-5		→ Seite 1-6		→ Seite 1-7	

✓ Auf Lager ○ Auf Anfrage, bitte Wunschtermin für die Lieferung angeben

Bestellbeispiel für:

Typ: LCMX 030502 FN l1=2.0
Ausführung: B020

- LCMX 030502 FN B020
- l1=2.0 tt.mm.jj (Wunschtermin)

Einleitung

- ISO-Bezeichnung 2-2
- Produktauswahl nach Anwendung / Schneidengeometrie / Schnittwerte 2-3

ISO-Fräsplatten mit Diamant-Schneiden

- Produktübersicht 2-4
- Schneidenausführung Mehrweg. 2-5

Finger- und Radiusfräser mit Diamant-Schneiden

- Produktübersicht 2-8
- Fingerfräser mit Stahl- und HM-Schaft. 2-9
- Radiusfräser mit HM-Schaft 2-10

Kugelfräser mit DIAPACT(PKD)-Schneiden

- Produktübersicht 2-11
- Kugelfräser mit DIAPACT(PKD)-Schneiden. 2-12

Vielzahnfräser mit DIAPACT(PKD)-Schneiden

- Produktübersicht 2-16
- Vielzahnfräser mit HM-Schaft. 2-17

Finger- und Radiusfräser mit gelaserten Diamant-Schneiden

- DIAPACT(PKD) Finger- und Radiusfräser 2-27
- CVD-DIAMANT Finger- und Radiusfräser 2-28

Bohrer mit CVD-DIAMANT gelaserten Schneiden

- CVD-DIAMANT Bohrer mit Innenkühlung 2-31

Hochglanzfräser

- Fräskopf und Diamantschneiden 2-33

Aufsteckfräser mit DIAPACT(PKD)-Schneiden

- Produktübersicht 2-18
- Aufsteckfräser 90° mit DIAPACT(PKD)-Schneiden . 2-19

Scheibenfräser mit DIAPACT(PKD)-Schneiden

- Produktübersicht 2-20
- Scheibenfräser mit DIAPACT(PKD)-Schneiden. 2-21

Gravierstichel mit Diamant-Schneiden

- Produktübersicht 2-14
- Gravierstichel mit Diamant-Schneiden 2-15

Fingerfräser BORAPACT(CBN), Fräskopfeinsätze und Fräskopf

- Produktübersicht 2-22
- Fingerfräser mit BORAPACT(CBN)-Schneiden 2-23
- Fräskopfeinsätze mit BORAPACT(CBN)-Schneiden 2-24
- Fräskopfeinsätze mit Diamant-Schneiden 2-25
- Fräskopf für Fräskopfeinsatz 2873. 2-26



Wendeschneidplatten ISO-Code

Form	Freiwinkel	Toleranz	Befestigung und/oder Spanbrecher	Eckenradius																																																																																																																	
H Sechskant	<table border="1"> <tr><th>Standard Freiwinkel</th></tr> <tr><td>A 3°</td></tr> <tr><td>B 5°</td></tr> <tr><td>C 7°</td></tr> <tr><td>D 15°</td></tr> <tr><td>E 20°</td></tr> <tr><td>F 25°</td></tr> <tr><td>G 30°</td></tr> <tr><td>N 0°</td></tr> <tr><td>P 11°</td></tr> <tr><td>O weitere Freiwinkel</td></tr> </table>	Standard Freiwinkel	A 3°	B 5°	C 7°	D 15°	E 20°	F 25°	G 30°	N 0°	P 11°	O weitere Freiwinkel	<table border="1"> <tr><th>Toleranz ohne Radius m [mm]</th></tr> <tr><td>A ±0.005</td></tr> <tr><td>F ±0.005</td></tr> <tr><td>C ±0.013</td></tr> <tr><td>H ±0.013</td></tr> <tr><td>E ±0.025</td></tr> <tr><td>G ±0.025</td></tr> <tr><td>J ±0.005</td></tr> <tr><td>K¹⁾ ±0.013</td></tr> <tr><td>L¹⁾ ±0.025</td></tr> <tr><td>M¹⁾ ±0.08~±0.18</td></tr> <tr><td>N¹⁾ ±0.08~±0.18</td></tr> <tr><td>U¹⁾ ±0.13~±0.38</td></tr> </table>	Toleranz ohne Radius m [mm]	A ±0.005	F ±0.005	C ±0.013	H ±0.013	E ±0.025	G ±0.025	J ±0.005	K ¹⁾ ±0.013	L ¹⁾ ±0.025	M ¹⁾ ±0.08~±0.18	N ¹⁾ ±0.08~±0.18	U ¹⁾ ±0.13~±0.38	<table border="1"> <tr><th>Inkreibstoleranz Ød [mm]</th></tr> <tr><td>±0.025</td></tr> <tr><td>±0.013</td></tr> <tr><td>±0.025</td></tr> <tr><td>±0.013</td></tr> <tr><td>±0.025</td></tr> <tr><td>±0.025</td></tr> <tr><td>±0.05~±0.13</td></tr> <tr><td>±0.05~±0.13</td></tr> <tr><td>±0.05~±0.13</td></tr> <tr><td>±0.05~±0.13</td></tr> <tr><td>±0.08~±0.25</td></tr> </table>	Inkreibstoleranz Ød [mm]	±0.025	±0.013	±0.025	±0.013	±0.025	±0.025	±0.05~±0.13	±0.05~±0.13	±0.05~±0.13	±0.05~±0.13	±0.08~±0.25	<table border="1"> <tr><th>Dickentoleranz s [mm]</th></tr> <tr><td>±0.025</td></tr> <tr><td>±0.025</td></tr> <tr><td>±0.025</td></tr> <tr><td>±0.025</td></tr> <tr><td>±0.13</td></tr> <tr><td>±0.025</td></tr> <tr><td>±0.025</td></tr> <tr><td>±0.13</td></tr> <tr><td>±0.025</td></tr> <tr><td>±0.13</td></tr> <tr><td>±0.13</td></tr> </table>	Dickentoleranz s [mm]	±0.025	±0.025	±0.025	±0.025	±0.13	±0.025	±0.025	±0.13	±0.025	±0.13	±0.13	<table border="1"> <tr><th>Loch</th></tr> <tr><td>W mit Loch</td></tr> <tr><td>T mit Loch</td></tr> <tr><td>Q mit Loch</td></tr> <tr><td>U mit Loch</td></tr> <tr><td>B mit Loch</td></tr> <tr><td>H mit Loch</td></tr> <tr><td>C mit Loch</td></tr> <tr><td>J mit Loch</td></tr> <tr><td>A mit Loch</td></tr> <tr><td>M mit Loch</td></tr> <tr><td>G mit Loch</td></tr> <tr><td>N ohne Loch</td></tr> <tr><td>R ohne Loch</td></tr> <tr><td>F ohne Loch</td></tr> <tr><td>X -</td></tr> </table>	Loch	W mit Loch	T mit Loch	Q mit Loch	U mit Loch	B mit Loch	H mit Loch	C mit Loch	J mit Loch	A mit Loch	M mit Loch	G mit Loch	N ohne Loch	R ohne Loch	F ohne Loch	X -	<table border="1"> <tr><th>Lochkonfiguration</th></tr> <tr><td>Zylindrisches Loch + Senkung (40°~60°)</td></tr> <tr><td>Zylindrisches Loch + Senkung (40°~60°)</td></tr> <tr><td>Zylindrisches Loch + Senkung (70°~90°)</td></tr> <tr><td>Zylindrisches Loch + Senkung (70°~90°)</td></tr> <tr><td>Zylindrisches Loch</td></tr> <tr><td>Zylindrisches Loch</td></tr> <tr><td>Zylindrisches Loch</td></tr> <tr><td>Zylindrisches Loch</td></tr> <tr><td>Zylindrisches Loch</td></tr> <tr><td>Zylindrisches Loch</td></tr> <tr><td>-</td></tr> <tr><td>-</td></tr> <tr><td>-</td></tr> <tr><td>-</td></tr> </table>	Lochkonfiguration	Zylindrisches Loch + Senkung (40°~60°)	Zylindrisches Loch + Senkung (40°~60°)	Zylindrisches Loch + Senkung (70°~90°)	Zylindrisches Loch + Senkung (70°~90°)	Zylindrisches Loch	Zylindrisches Loch	Zylindrisches Loch	Zylindrisches Loch	Zylindrisches Loch	Zylindrisches Loch	-	-	-	-	<table border="1"> <tr><th>Spanbrecher</th></tr> <tr><td>ohne</td></tr> <tr><td>einseitig</td></tr> <tr><td>ohne</td></tr> <tr><td>doppel-seitig</td></tr> <tr><td>ohne</td></tr> <tr><td>einseitig</td></tr> <tr><td>ohne</td></tr> <tr><td>doppel-seitig</td></tr> <tr><td>ohne</td></tr> <tr><td>einseitig</td></tr> <tr><td>einseitig</td></tr> <tr><td>doppel-seitig</td></tr> <tr><td>ohne</td></tr> <tr><td>einseitig</td></tr> <tr><td>doppel-seitig</td></tr> <tr><td>-</td></tr> <tr><td>spezielles Design</td></tr> </table>	Spanbrecher	ohne	einseitig	ohne	doppel-seitig	ohne	einseitig	ohne	doppel-seitig	ohne	einseitig	einseitig	doppel-seitig	ohne	einseitig	doppel-seitig	-	spezielles Design	<table border="1"> <tr><th>Plattentyp</th></tr> <tr><td>00 ohne Radius</td></tr> <tr><td>002 0.02</td></tr> <tr><td>005 0.05</td></tr> <tr><td>010 0.10</td></tr> <tr><td>015 0.15</td></tr> <tr><td>020 0.20</td></tr> <tr><td>040 0.40</td></tr> <tr><td>050 0.50</td></tr> <tr><td>080 0.80</td></tr> <tr><td>100 1.00</td></tr> <tr><td>120 1.20</td></tr> </table>	Plattentyp	00 ohne Radius	002 0.02	005 0.05	010 0.10	015 0.15	020 0.20	040 0.40	050 0.50	080 0.80	100 1.00	120 1.20
Standard Freiwinkel																																																																																																																					
A 3°																																																																																																																					
B 5°																																																																																																																					
C 7°																																																																																																																					
D 15°																																																																																																																					
E 20°																																																																																																																					
F 25°																																																																																																																					
G 30°																																																																																																																					
N 0°																																																																																																																					
P 11°																																																																																																																					
O weitere Freiwinkel																																																																																																																					
Toleranz ohne Radius m [mm]																																																																																																																					
A ±0.005																																																																																																																					
F ±0.005																																																																																																																					
C ±0.013																																																																																																																					
H ±0.013																																																																																																																					
E ±0.025																																																																																																																					
G ±0.025																																																																																																																					
J ±0.005																																																																																																																					
K ¹⁾ ±0.013																																																																																																																					
L ¹⁾ ±0.025																																																																																																																					
M ¹⁾ ±0.08~±0.18																																																																																																																					
N ¹⁾ ±0.08~±0.18																																																																																																																					
U ¹⁾ ±0.13~±0.38																																																																																																																					
Inkreibstoleranz Ød [mm]																																																																																																																					
±0.025																																																																																																																					
±0.013																																																																																																																					
±0.025																																																																																																																					
±0.013																																																																																																																					
±0.025																																																																																																																					
±0.025																																																																																																																					
±0.05~±0.13																																																																																																																					
±0.05~±0.13																																																																																																																					
±0.05~±0.13																																																																																																																					
±0.05~±0.13																																																																																																																					
±0.08~±0.25																																																																																																																					
Dickentoleranz s [mm]																																																																																																																					
±0.025																																																																																																																					
±0.025																																																																																																																					
±0.025																																																																																																																					
±0.025																																																																																																																					
±0.13																																																																																																																					
±0.025																																																																																																																					
±0.025																																																																																																																					
±0.13																																																																																																																					
±0.025																																																																																																																					
±0.13																																																																																																																					
±0.13																																																																																																																					
Loch																																																																																																																					
W mit Loch																																																																																																																					
T mit Loch																																																																																																																					
Q mit Loch																																																																																																																					
U mit Loch																																																																																																																					
B mit Loch																																																																																																																					
H mit Loch																																																																																																																					
C mit Loch																																																																																																																					
J mit Loch																																																																																																																					
A mit Loch																																																																																																																					
M mit Loch																																																																																																																					
G mit Loch																																																																																																																					
N ohne Loch																																																																																																																					
R ohne Loch																																																																																																																					
F ohne Loch																																																																																																																					
X -																																																																																																																					
Lochkonfiguration																																																																																																																					
Zylindrisches Loch + Senkung (40°~60°)																																																																																																																					
Zylindrisches Loch + Senkung (40°~60°)																																																																																																																					
Zylindrisches Loch + Senkung (70°~90°)																																																																																																																					
Zylindrisches Loch + Senkung (70°~90°)																																																																																																																					
Zylindrisches Loch																																																																																																																					
Zylindrisches Loch																																																																																																																					
Zylindrisches Loch																																																																																																																					
Zylindrisches Loch																																																																																																																					
Zylindrisches Loch																																																																																																																					
Zylindrisches Loch																																																																																																																					
-																																																																																																																					
-																																																																																																																					
-																																																																																																																					
-																																																																																																																					
Spanbrecher																																																																																																																					
ohne																																																																																																																					
einseitig																																																																																																																					
ohne																																																																																																																					
doppel-seitig																																																																																																																					
ohne																																																																																																																					
einseitig																																																																																																																					
ohne																																																																																																																					
doppel-seitig																																																																																																																					
ohne																																																																																																																					
einseitig																																																																																																																					
einseitig																																																																																																																					
doppel-seitig																																																																																																																					
ohne																																																																																																																					
einseitig																																																																																																																					
doppel-seitig																																																																																																																					
-																																																																																																																					
spezielles Design																																																																																																																					
Plattentyp																																																																																																																					
00 ohne Radius																																																																																																																					
002 0.02																																																																																																																					
005 0.05																																																																																																																					
010 0.10																																																																																																																					
015 0.15																																																																																																																					
020 0.20																																																																																																																					
040 0.40																																																																																																																					
050 0.50																																																																																																																					
080 0.80																																																																																																																					
100 1.00																																																																																																																					
120 1.20																																																																																																																					

Drehen: **C** **N** **M** **G** **12** **04** **08** **T** **B010**

Fräsen: **S** **E** **K** **N** **12** **03** **AF** **T** **B010**

Wendeschneidplattengröße								
Inkreis [mm]	R	W	V	G	D	C	S	T
3.97		02				03	03	06
6.00	06							
6.35		04	11		07	06	06	11
7.94		05			09	08	07	13
8.00	08							
9.525	09	06	16		11	09	09	16
10.00	10							
12.00	12							
12.70	12	08	19		15	12	12	22
15.875		10			19	16	15	27
16.00	16							
19.05	19	13			23	19	19	33
20.00	20							
22.225					27	22	22	38
25.00	25							
25.40	25				31	25	25	44
31.75	31				38	32	31	55
32.00	32							

Stärke	
Metrisch	Stärke [mm]
01	1.59
02	2.38
T2	2.78
03	3.18
T3	3.97
04	4.76
06	6.35
07	7.94
09	9.52

Anstellwinkel	
A	45°
E	75°
P	90°
Standardfreiwinkel der Breitschlichtplanfase	
D	15°
E	20°
F	25°
N	0°
P	11°

Schneidkantenausführung		
F	scharfkantig	
E	verrundet	
T	gefast	
S	gefast und verrundet	

Herstellerangaben	
Herstellerspezifische Angaben mit Ziffern und/oder Buchstaben	
Werkzeuge von WEISS AG	
Code	Typ
A010	Diamant-Werkzeuge
AXXX	
B010	CBN-Werkzeuge
BXXX	

¹⁾ Generell gilt dasselbe für gesinterte WSP, zum Teil abhängig von der Größe



Fräsen

Produktauswahl nach Anwendung

Anwendung	Bezeichnung	Sortenübersicht	Eigenschaften
Schruppen und Schlichten von gehärteten Stählen ab 45 HRC bis 70 HRC	BORAPACT (CBN)	B010 B020 B040 B050 B060 B070 B075 B080	Hohe Abriebfestigkeit, hervorragende Schlagfestigkeit, ausgezeichnete Schneidkantenqualität und -stabilität. Feine Oberflächengüten, höchste Wärmebeständigkeit
Schruppen und Schlichten aller NE-Metalle, Kunststoffe je nach Sorte mit mehr oder weniger abrasiven Füllstoffen, Hartmetall, Keramik, Platin, Gold	DIAPACT (PKD)	A010 A020 A030 A040	Mit Hartmetallunterlage, hohe Abriebfestigkeit, gute bis sehr gute Schneidenqualität
Schruppen und Schlichten von abrasiven NE-Metallen, Kunststoffen mit abrasiven Füllstoffen, Grafit, Hartmetall, Keramikgrünlingen	CVD-Diamant	A060	Ohne Hartmetallunterlage und ohne metallische Bindephase, 99.9% Diamantanteil, scharfenfreie Schneidkanten, höchste Verschleissfestigkeit, hohe Wärmeleitfähigkeit
Schlichten von NE-Metallen, Kunststoffen ohne abrasive Füllstoffe, Edelmetallen, Acrylglas, allgemein für Hochglanzbearbeitungen und feinste Oberflächengüten	MKD	A070	Synthetische, monokristalline Diamantplatten, synthetischer Einkristalldiamant, höchste Härte, höchste Schneidenschärfe, vordefinierte Schnittkrafttrichtung, geringe Bruchzähigkeit
	Naturdiamant	A080	Naturdiamant, höchste Härte, höchste Schneidenschärfe, geringe Bruchzähigkeit

Wahl der Schneidengeometrie

Fräswerkzeuge besitzen normalerweise mehrere Schneiden. Speziell für das Fräsen ist der unterbrochene Schnitt, da jede Schneide nur vorübergehend im Eingriff ist.

- Freiwinkel α
Verringerung der Reibung
- Keilwinkel γ
Je weicher der zu bearbeitende Werkstoff, desto kleiner ist der Keilwinkel zu wählen, umso geringer ist die Gratbildung, aber auch die Standzeit der Schneide
- Spanwinkel β
Je weicher der zu bearbeitende Werkstoff, desto grösser ist der Spanwinkel zu wählen. Harte oder spröde Werkstoffe erfordern dagegen keine oder sogar negative Spanwinkel

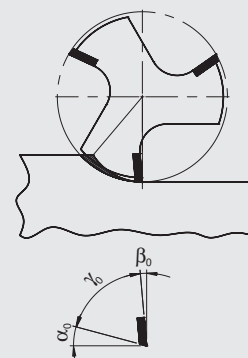

Schnittwerte

Die Schnittgeschwindigkeit und die Vorschubgeschwindigkeit überlagern sich und führen zu einem kontinuierlichen Zerspanungsvorgang.

D_c Schneiddurchmesser [mm]
 V_c Schnittgeschwindigkeit
 n Drehzahl
 V_f Vorschub
 f_n Vorschub pro Umdrehung
 f_z Vorschub pro Zahn
 z_n Anzahl der Schneidecken im Werkzeug

- Schnittgeschwindigkeit [m/min]

$$V_c = \frac{D_c \times \pi \times n}{1000}$$

- Drehzahl [U/min]

$$n = \frac{V_c \times 1000}{D_c \times \pi}$$

- Vorschub [mm/min]

$$V_f = f_z \times n \times z_n$$

- Vorschub pro Umdrehung [mm/U]

$$f_n = \frac{V_f}{n}$$

- Vorschub pro Zahn [mm]

$$f_z = \frac{V_f}{n \times z_n}$$

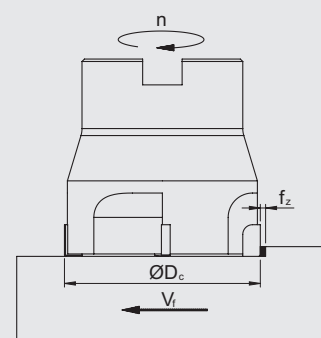



Produktspektrum

ISO-Fräsplatten mit Diamant-Schneiden

→ Seite 2-5

Vorteile im Überblick

- Engste Masstoleranzen und feinste Oberflächen
- Höchste Standzeiten
- Minimierte Ausschussraten
- Geringe oder keine Gratbildung

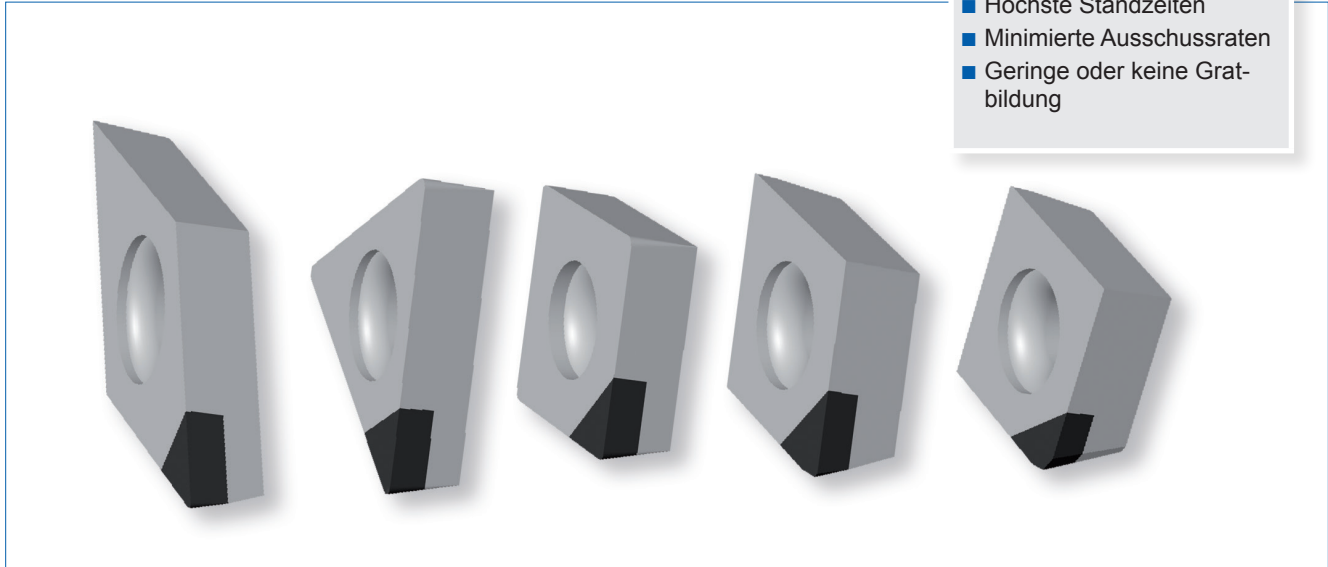

Produktmerkmale

- Diamant-Rohlinge hartgelötet oder vakuumgelötet auf handelsübliche Hartmetallwendeplatten.
- Je nach Schneidstoff enthalten die Diamanten weiche Bindemittel (PKD) oder keine (CVD-Diamant, MKD und Naturdiamant).
- Wahl der Diamantsorte je nach Anwendung.

Anwendungsbereiche

Werkzeuge mit Diamantschneiden erzielen hervorragende Ergebnisse im Hinblick auf Standzeit, Oberflächengüten sowie Produktionszeiten und sind somit vor allem geeignet bei hohen Stückzahlen oder bei hohem Werkzeugverschleiss.

Durch die hohe Abriebfestigkeit ergeben sich sehr lange Nutzungszeiten der Werkzeuge und somit geringe Stillstandzeiten der Produktionsmaschinen.

PKD-Werkzeuge	CVD-Diamant-Werkzeuge	MKD-Werkzeuge	Naturdiamant-Werkzeuge
Al-Si-Legierungen bis 20 % Si	Al-Si-Legierungen ab 13 % Si	Alu-Legierungen bis 6 % Si	Alu-Legierungen bis 6 % Si
Keramik ungesintert und gesintert	MMCs	Kupfer	Kupfer
Kupferlegierungen	GFK/Grafit	Gold	Gold
GFK/CFK	Wolfram	Silber	Silber
Hartmetalle ungesintert und gesintert	Thermoplast mit Kohlefaser, Teflon mit hohem Glasanteil	Kunststoffe	Kunststoffe

Einsatzbedingungen

- Schneiden nie mechanisch vermessen (Ausbruchgefahr).
- Werkzeuge vor Schneidenbruch nachschleifen lassen.
- Für unterbrochenen Schnitt die Schnittwerte ca. halbieren.
- Intensive Kühlung mit leichter Bohremulsion verbessert die Schnittleistung erheblich.
- Möglichst hohe Schnittwerte anstreben, um so die Reibung zu reduzieren und dadurch die Standzeit des Werkzeugs zu erhöhen.



ISO-Fräsplatten mit Diamant-Schneiden

- Schneidenausführung **Mehrweg**
(ausser Typ SPGW in Ein- und Mehrweg)

Typ CCMW

		Abmessungen				Typ
		l1 [mm]	l [mm]	s [mm]	r [mm]	
	α					
	7°	3.7	6.45	2.38	0.2	CCMW 06 02 02 F A0..
		3.6	6.45	2.38	0.4	CCMW 06 02 04 F A0..
		4.7	6.45	3.97	0.2	CCMW 09 T3 02 F A0..
		4.6	6.45	3.97	0.4	CCMW 09 T3 04 F A0..
		4.5	6.45	3.97	0.8	CCMW 09 T3 08 F A0..
		4.6	12.9	4.76	0.4	CCMW 12 04 04 F A0..
		4.5	12.9	4.76	0.8	CCMW 12 04 08 F A0..

Typ CPGW

		Abmessungen				Typ
		l1 [mm]	l [mm]	s [mm]	r [mm]	
	α					
	11°	2.7	5.6	2.38	0.2	CPGW 05 02 02 F A0..
		2.6	5.6	2.38	0.4	CPGW 05 02 04 F A0..
		3.6	6.45	2.38	0.2	CPGW 06 02 02 F A0..
		3.5	6.45	2.38	0.4	CPGW 06 02 04 F A0..
		3.5	12.9	4.76	0.4	CPGW 12 04 04 F A0..
		5.8	12.9	4.76	0.4	CPGW 12 04 04 F A0..
		3.4	12.9	4.76	0.8	CPGW 12 04 08 F A0..
5.7		12.9	4.76	0.8	CPGW 12 04 08 F A0..	
	11°	4.7	12.9	4.76	–	CPGW 12 04 EDR F A0..

Typ DCMW

		Abmessungen				Typ
		l1 [mm]	l [mm]	s [mm]	r [mm]	
	α					
	7°	3.2	7.75	2.38	0.2	DCMW 07 02 02 F A0..
		3.0	7.75	2.38	0.4	DCMW 07 02 04 F A0..
		4.2	11.6	3.97	0.2	DCMW 11 T3 02 F A0..
		4.0	11.6	3.97	0.4	DCMW 11 T3 04 F A0..
		3.7	11.6	3.97	0.8	DCMW 11 T3 08 F A0..

Typ SCMW

		Abmessungen				Typ
		l1 [mm]	l [mm]	s [mm]	r [mm]	
	α					
	7°	3.6	9.52	3.97	0.2	SCMW 09 T3 02 F A0..
		3.6	9.52	3.97	0.4	SCMW 09 T3 04 F A0..
		3.6	9.52	3.97	0.8	SCMW 09 T3 08 F A0..
		4.6	12.7	4.76	0.2	SCMW 12 04 02 F A0..
		4.6	12.7	4.76	0.4	SCMW 12 04 04 F A0..
4.6		12.7	4.76	0.8	SCMW 12 04 08 F A0..	

Fortsetzung und Bestellinformationen siehe nächste Seite



Typ SPGW

	Abmessungen			Typ	
	α	l1 [mm]	l [mm]		s [mm]
	11°	3.5	12.7	4.76	SPGW 12 04 EDR F-E A0.. ¹⁾
		5.5	12.7	4.76	SPGW 12 04 EDR F A0..

¹⁾ Schneidenausführung Einweg

Typ TCMW

	Abmessungen				Typ	
	α	l1 [mm]	l [mm]	s [mm]		r [mm]
	7°	3.4	9.63	2.38	0.2	TCMW 09 02 02 F A0..
		3.2	9.63	2.38	0.4	TCMW 09 02 04 F A0..
		3.0	9.63	2.38	0.8	TCMW 09 02 08 F A0..
		3.4	11.0	2.38	0.2	TCMW 11 02 02 F A0..
		3.2	11.0	2.38	0.4	TCMW 11 02 04 F A0..
		3.0	11.0	2.38	0.8	TCMW 11 02 08 F A0..
		4.4	16.5	3.97	0.2	TCMW 16 T3 02 F A0..
		4.2	16.5	3.97	0.4	TCMW 16 T3 04 F A0..
		4.0	16.5	3.97	0.8	TCMW 16 T3 08 F A0..

Typ TPMW

	Abmessungen				Typ	
	α	l1 [mm]	l [mm]	s [mm]		r [mm]
	11°	3.4	11.0	2.38	0.2	TPMW 11 02 02 F A0..
		3.2	11.0	2.38	0.4	TPMW 11 02 04 F A0..
		3.0	11.0	2.38	0.8	TPMW 11 02 08 F A0..

Bestellinformationen

Verfügbare Ausführungen

Bestell-Code	DIAPACT(PKD)					CVD-Diam.	MKD	Naturdiam.
	A010	A020	A030	A040	A041	A060	A070	A080
Verfügbarkeit	✓	○	○	○	○	○	○	○
Weitere Infos	→ Seite 1-6					→ Seite 1-7		

✓ Auf Lager ○ Auf Anfrage, bitte Wunschtermin für die Lieferung angeben

Bestellbeispiel für:

Typ: CPGW 12 04 04 F A0..
Ausführung: DIAPACT A040

- CPGW 12 04 04 F A040
- l1 = 5.8 mm¹⁾
- tt.mm.jj (Wunschtermin)

¹⁾ Die Schneidkantenlänge l1 sollte bei MKD- und Naturdiamant-Werkzeugen aus Kostengründen möglichst kurz gewählt werden.





Produktspektrum

Fingerfräser mit Diamant-Schneiden
Radiusfräser mit Diamant-Schneiden

→ Seite 2-9
→ Seite 2-10

Vorteile im Überblick

- Engste Masstoleranzen und feinste Oberflächen
- Höchste Standzeiten
- Minimierte Ausschussraten
- Geringe oder keine Gratbildung

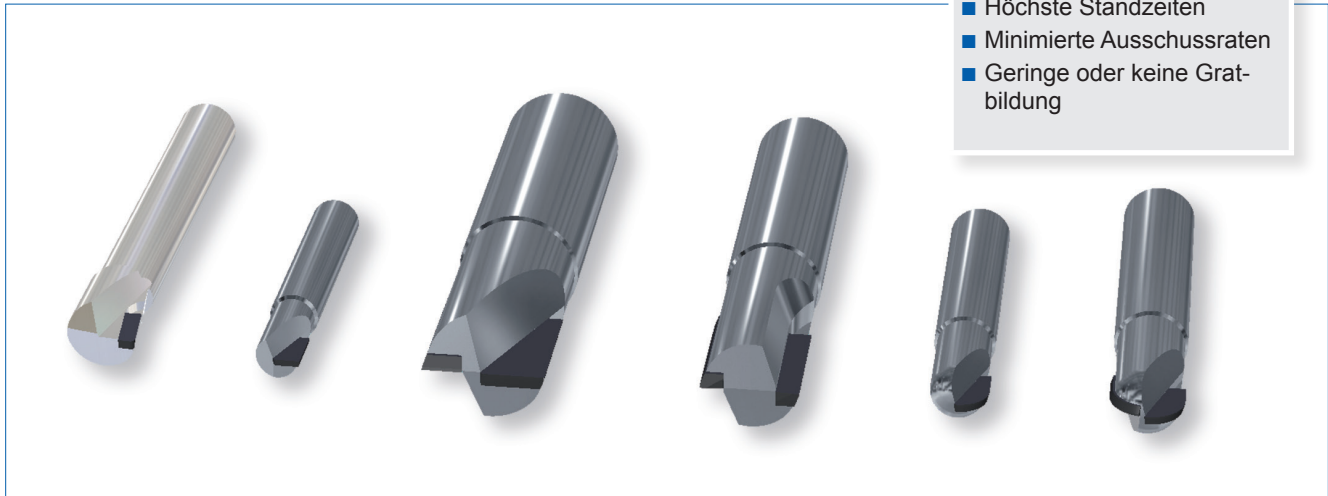

Produktmerkmale

- Diamant-Einsätze hartgelötet auf Hartmetall-Rohlinge.
- Je nach Schneidstoff enthalten die Diamanten weiche Bindemittel (PKD) oder keine (CVD-Diamant, MKD und Naturdiamant).
- Wahl der Diamantsorte je nach Anwendung.

Anwendungsbereiche

Werkzeuge mit Diamantschneiden erzielen hervorragende Ergebnisse im Hinblick auf Standzeit, Oberflächengüten sowie Produktionszeiten und sind somit vor allem geeignet bei hohen Stückzahlen oder bei hohem Werkzeugverschleiss.

Durch die hohe Abriebfestigkeit ergeben sich sehr lange Nutzungszeiten der Werkzeuge und somit geringe Stillstandzeiten der Produktionsmaschinen.

PKD-Fräser	CVD-Diamant-Fräser	MKD-Fräser	Naturdiamant-Fräser
Al-Si-Legierungen bis 20 % Si	Al-Si-Legierungen ab 13 % Si	Alu-Legierungen bis 6 % Si	Alu-Legierungen bis 6 % Si
Keramik ungesintert und gesintert	MMCs	Kupfer	Kupfer
Kupferlegierungen	GFK/Grafit	Gold	Gold
GFK/CFK	Wolfram	Silber	Silber
Hartmetalle ungesintert und gesintert	Thermoplast mit Kohlefaser, Teflon mit hohem Glasanteil	Kunststoffe	Kunststoffe

Einsatzbedingungen

- Schneiden nie mechanisch vermessen (Ausbruchgefahr).
- Fräser vor Schneidenbruch nachschleifen lassen.
- Für unterbrochenen Schnitt die Schnittwerte ca. halbieren.
- Intensive Kühlung mit leichter Bohremulsion verbessert die Schnittleistung erheblich.
- Möglichst hohe Schnittwerte anstreben, um so die Reibung zu reduzieren und dadurch die Standzeit der Fräser zu erhöhen.



Fingerfräser mit Diamant-Schneiden (rechtsdrehend)

Typ 2871 mit Stahl-Schaft

Schneidzahl und Ausführung	Abmessungen						Typ
	$\varnothing D \pm 0.5$ [mm]	$\varnothing d$ [mm]	l [mm]	l_1 [mm]	l_2 [mm]	r [mm]	
einschneidig, ohne Zentrumschnitt	6	6	60	4.5	–	0.4	2871-6 A0..
	8	6	60	4.5	10	0.4	2871-8 A0..
	10	8	60	4.5	10	0.4	2871-10 A0..
	12	10	80	8	15	0.8	2871-12 A0..
	14	10	80	8	15	0.8	2871-14 A0..
	16	12	80	8	15	0.8	2871-16 A0..
	18	14	100	8	20	0.8	2871-18 A0..
	20	16	100	8	20	0.8	2871-20 A0..
	25	20	100	8	20	0.8	2871-25 A0..

Typ 2875 mit HM-Schaft

Schneidzahl und Ausführung	Abmessungen					Typ
	$\varnothing D \pm 0.02$ [mm]	$\varnothing d$ [mm]	l [mm]	l_1 [mm]	l_2 [mm]	
einschneidig, Zentrumschnitt	0.8	6	50	2.5	2.5	2875-0.8 A045
	1	6	50	3	3	2875-1 A045
	1.5	6	50	3.5	3.5	2875-1.5 A045
	2	6	50	4.5	4.5	2875-2 A045
	2.5	6	50	5.5	5.5	2875-2.5 A045
	3	6	50	6.5	6.5	2875-3 A045
	3.5	6	50	7	7.5	2875-3.5 A045
	4	6	50	4	14	2875-4 A0..
	5	6	50	5	14	2875-5 A0..
	6	6	50	6	14	2875-6 A0..
	8	8	50	8	14	2875-8 A0..
	10	10	60	10	20	2875-10 A0..
12	12	65	12	20	2875-12 A0..	

Typ 2876 mit HM-Schaft

Schneidzahl und Ausführung	Abmessungen					Typ
	$\varnothing D \pm 0.02$ [mm]	$\varnothing d$ [mm]	l [mm]	l_1 [mm]	l_2 [mm]	
zweischneidig, ohne Zentrumschnitt	6	6	60	6	15	2876-6 A0..
	8	8	65	8	20	2876-8 A0..
	10	10	70	10	25	2876-10 A0..
	12	12	70	12	25	2876-12 A0..
	14	16	80	14	32	2876-14 A0..
	16	16	80	16	32	2876-16 A0..
	20	20	90	20	40	2876-20 A0..

Bestellinformationen

Verfügbare Ausführungen

Bestell-Code	DIAPACT					CVD-Diam. A060	MKD A070	Naturdiam. A080
	A010	A020	A030	A040	A041			
Verfügbarkeit	✓	○	○	○	○	○	○	○
Weitere Infos	→ Seite 1-6					→ Seite 1-7		

✓ Auf Lager ○ Auf Anfrage, bitte Wunschtermin für die Lieferung angeben

Bestellbeispiel für:

Typ: 2876-12 A0..
Ausführung: MKD

- 2876-12 A070
- tt.mm.jj (Wunschtermin)

Die Schneidkantenlänge l_1 kann angegeben werden und sollte bei MKD- und Naturdiamant-Werkzeugen aus Kostengründen möglichst kurz gewählt werden.



Finger- und Radiusfräser mit Diamant-Schneiden

Mit HM-Schaft | ein- und zweisehnidig

Typ 2877 mit HM-Schaft

Schneidenzahl und Ausführung	Abmessungen					Typ
	$\varnothing D \pm 0.02$ [mm]	$\varnothing d$ [mm]	l [mm]	l1 [mm]	l2 [mm]	
zweisehnidig, Zentrumschnitt	6	6	60	6	15	2877-6 A0..
	8	8	65	8	20	2877-8 A0..
	10	12	70	10	25	2877-10 A0..
	12	12	70	12	25	2877-12 A0..
	14	16	80	14	32	2877-14 A0..
	16	16	80	16	32	2877-16 A0..
	20	20	90	20	40	2877-20 A0..

Typ 2878 mit HM-Schaft

Schneidenzahl und Ausführung	Abmessungen					Typ
	$\varnothing D^{0-0.02}/R$ [mm]	$\varnothing d$ [mm]	l [mm]	l1 [mm]	l2 [mm]	
einschnidig, Zentrumschnitt	0.8 / 0.4	6	50	2.5	2.5	2878-0.8 A045
	1 / 0.5	6	50	3	3	2878-1 A045
	1.5 / 0.75	6	50	3.5	3.5	2878-1.5 A045
	2 / 1	6	50	4	4.5	2878-2 A045
	2.5 / 1.25	6	50	5	5.5	2878-2.5 A045
	3 / 1.5	6	50	6	6.5	2878-3 A045
	3.5 / 1.75	6	50	7	7.5	2878-3.5 A045
	4 / 2	6	50	4	10	2878-4 A0..
	6 / 3	6	50	6	14	2878-6 A0..
	8 / 4	8	50	8	14	2878-8 A0..
	10 / 5	10	60	10	20	2878-10 A0..
	12 / 6	12	65	12	20	2878-12 A0..
	16 / 8	16	80	16	32	2878-16 A0..

Typ 2879 mit HM-Schaft

Schneidenzahl und Ausführung	Abmessungen					Typ
	$\varnothing D^{0-0.02}/R$ [mm]	$\varnothing d$ [mm]	l [mm]	l1 [mm]	l2 [mm]	
zweisehnidig, Zentrumschnitt	6 / 3	6	50	6	14	2879-6 A0..
	8 / 4	8	50	8	14	2879-8 A0..
	10 / 5	10	60	10	20	2879-10 A0..
	12 / 6	12	65	12	20	2879-12 A0..

Bestellinformationen

Verfügbare Ausführungen	DIAPACT(PKD)					CVD-Diam.	MKD	Naturdiam.
	A010	A020	A030	A040	A041			
Bestell-Code	A010	A020	A030	A040	A041	A060	A070	A080
Verfügbarkeit	✓	○	○	○	○	○	○	○
Weitere Infos	→ Seite 1-6					→ Seite 1-7		

✓ Auf Lager ○ Auf Anfrage, bitte Wunschtermin für die Lieferung angeben

Die Schneidkantenlänge l1 kann angegeben werden und sollte bei MKD- und Naturdiamant-Werkzeugen aus Kostengründen möglichst kurz gewählt werden.



Produktspektrum

Kugelfräser 2-schneidig mit DIAPACT- (PKD)-Schneiden

→ Seite 2-12

Vorteile im Überblick

- Hohe Standzeit
- Hohe Schnittgeschwindigkeit
- Hinterschnitt möglich

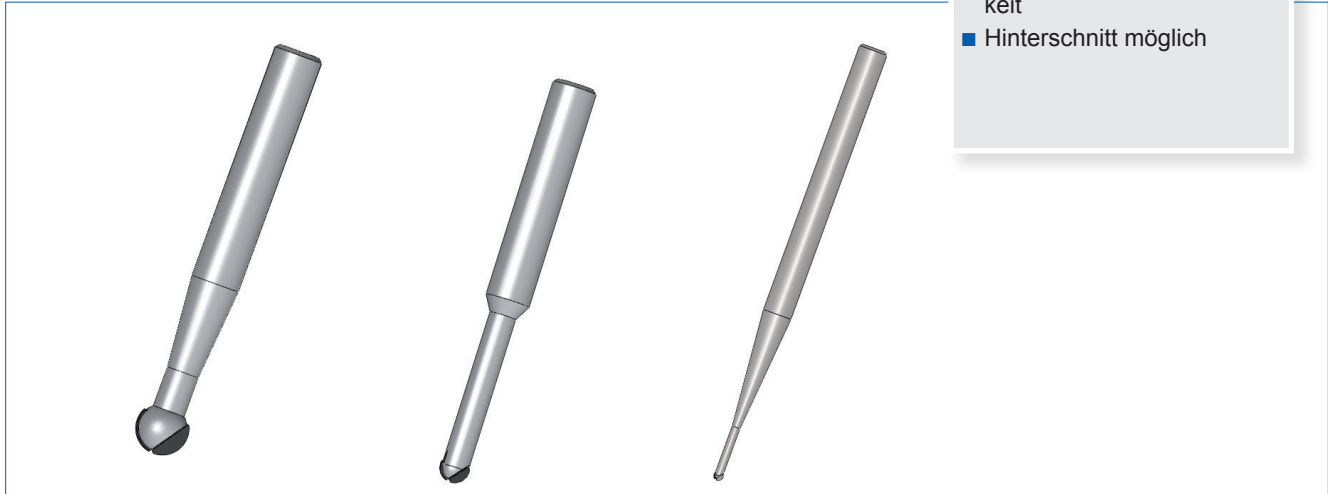

Produktmerkmale

- DIAPACT(PKD)-Ausführung hartgelötet auf HM-Rohling
- Verwendung von spezieller PKD-Sorte
- Schneiden Drahterodiert

Anwendungsbereiche

2880 Kugelfräser mit DIAPACT(PKD)-Schneiden werden hauptsächlich bei Graphit, gesintertem und ungesintertem Keramik sowie Aluminium eingesetzt und erreichen im

Bereich Standzeit, Schnittgeschwindigkeit und Vorschub höchste Anforderungen.

Hauptanwendung	Schnittgeschwindigkeit V (m / min.)	Vorschub (mm / Zahn)	Schnitttiefe (mm)
Graphit	200 – 1000	0.05 – 0.25	0.02 – 0.30
Keramik gesintert	50 – 150	0.05 – 0.15	0.02 – 0.15
Keramik ungesintert	100 – 500	0.05 – 0.25	0.02 – 0.30
Aluminium	200 – 1000	0.05 – 0.25	0.02 – 0.50

Einsatzbedingungen

- Schneiden nie mechanisch vermessen (Ausbruchgefahr).
- Intensive Kühlung mit leichter Bohremulsion verbessert die Schnittleistung erheblich.
- Möglichst hohe Schnittwerte anstreben, um so die Reibung zu reduzieren und dadurch die Standzeit der Fräser zu erhöhen.



Kugelfräser mit Diamant-Schneiden

Mit HM-Schaft | ein- und zweischneidig

WEISS Kugelfräser mit DIAPACT (PKD)-Schneiden (rechtsdrehend)

Mit HM-Schaft

Typ 2880

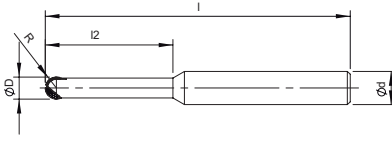
	Schneidenzahl und Ausführung	Abmessungen				Typ
		$\text{ØD}^{0-0.02}/R$ [mm]	Ød [mm]	l [mm]	l2 [mm]	
zweischneidig, Zentrumschnitt	2 / 1	6	58	6	2880-2 A058	
	2.5 / 1.25	6	58	6	2880-2.5 A058	
	3 / 1.5	6	65	15	2880-3 A058	
	3.5 / 1.75	6	65	15	2880-3.5 A058	
	4 / 2	6	70	20	2880-4 A058	
	5 / 2.5	6	80	25	2880-5 A058	
	6 / 3	8	85	30	2880-6 A058	
	8 / 4	8	90	35	2880-8 A058	

Typ 2881

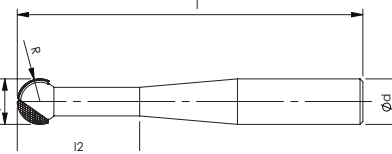
	Schneidenzahl und Ausführung	Abmessungen				Typ
		$\text{ØD}^{0-0.02}/R$ [mm]	Ød [mm]	l [mm]	l2 [mm]	
zweischneidig, Zentrumschnitt, Hinterschnitt	2 / 1	6	94	11.5	2881-2 A058	
	2.5 / 1.25	6	94	11.5	2881-2.5 A058	
	3 / 1.5	6	94	14	2881-3 A058	
	3.5 / 1.75	6	94	17.5	2881-3.5 A058	
	4 / 2	6	94	23	2881-4 A058	
	5 / 2.5	6	94	28	2881-5 A058	
	6 / 3	8	100	32	2881-6 A058	
	8 / 4	8	120	36.5	2881-8 A058	

Bestellinformationen

Verfügbare Ausführungen	DIAPACT(PKD)	Bestellbeispiel für: Typ: 2880-8 A0.. Ausführung: A058 ■ 2880-8 A058 ¹⁾ ■ tt.mm.jj (Wunschtermin)
Bestell-Code	A058	
Verfügbarkeit	✓	
✓ Auf Lager		





Produktspektrum

2888 Diamant Gravierstichel

→ Seite 2-15

Vorteile im Überblick

- zentrumsschneidend
- spezielles Werkzeug zum Gravieren und Kopieren



Produktmerkmale

- DIAPACT(PKD)-Ausführung hartgelötet auf HM-Rohling.
- Verwendung einer feinen PKD-Sorte
- einschneidig
- kegelförmiger Anschlag
- nachschleifbar

Anwendungsbereiche

Mit 2888 Diamant-Gravierstichel werden hauptsächlich bei Aluminium, Kunststoff, Messing, Kupfer, Grafit, Faserverbundwerkstoffe oder Gold eingesetzt. Anwendung auf Gravieren- oder Fräsmaschinen.

Drehzahlbereich: 20.000 - 30.000 U / min

Vorschubbereich: 0.7 - 0.12 m / min

Einsatzbedingungen

- Schneiden nie mechanisch vermessen (Ausbruchgefahr).
- Möglichst hohe Schnittwerte anstreben, um so die Reibung zu reduzieren und dadurch die Standzeit der Gravierstichel zu erhöhen



2888-Gravierstichel mit Diamant-Schneiden (rechtsdrehend)

■ Mit HM-Schaft

Typ 2888

Schneidenzahl	Winkel a	Abmessungen		l [mm]	Typ	
		Ød2 [mm]	Ød1 [mm]			
1	40°	3.0	0.10	40	2888-3-40-0.10 A0..	
			0.15		2888-3-40-0.15 A0..	
		6.0	0.10		2888-6-40-0.10 A0..	
			0.15		2888-6-40-0.15 A0..	
		50°	3.0		0.05	2888-3-50-0.05 A0..
					0.10	2888-3-50-0.10 A0..
	6.0		0.15		2888-3-50-0.15 A0..	
			0.05		2888-6-50-0.05 A0..	
	6.0		0.10		2888-6-50-0.10 A0..	
			0.15		2888-6-50-0.15 A0..	
	60°	3.0	0.05		2888-3-60-0.05 A0..	
			0.10		2888-3-60-0.10 A0..	
		6.0	0.15	2888-3-60-0.15 A0..		
			0.05	2888-6-60-0.05 A0..		
		6.0	0.10	2888-6-60-0.10 A0..		
			0.15	2888-6-60-0.15 A0..		
	90°	3.0	0.10	2888-3-90-0.10 A0..		
			0.15	2888-3-90-0.15 A0..		
6		0.10	2888-6-90-0.10 A0..			
		0.15	2888-6-90-0.15 A0..			

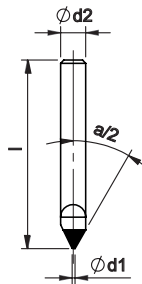

Bestellinformationen

Verfügbare Ausführungen	DIAPACT(PKD)	Diamant	
Bestell-Code	A030	A070	A080
Verfügbarkeit	<input type="radio"/>	<input type="radio"/>	<input type="radio"/>

Auf Anfrage, bitte Wunschtermin für die Lieferung angeben

Bestellbeispiel:

■ 2888-3-40-0.10 A070



Produktspektrum

WEISS-Vielzahnfräser mit DIAPACT (PKD)-Schneiden

→ Seite 2-17

Vorteile im Überblick

- Hohe Schneidenzahl
- Hohe Schnittgeschwindigkeiten
- Hohe Standzeit



Produktmerkmale

- DIAPACT(PKD)-Einsätze hartgelötet auf HM-Rohling.
- Verwendung einer speziellen PKD-Sorte (A056)
- Schneiden drahterodiert

Anwendungsbereiche

WEISS-Vielzahnfräser mit DIAPACT(PKD)-Schneiden werden hauptsächlich bei Grafit, gesinterter und ungesinterter Keramik eingesetzt und genügen im Hinblick auf Standzeit, Schnittgeschwindigkeit und Vorschub höchsten Anforderungen.

Hauptanwendung	Schnittgeschwindigkeit V [m/min]	Vorschub [mm/Zahn]	Schnitttiefe [mm]
Grafit	200 – 1000	0.05 – 0.25	0.02 – 0.30
Keramik gesintert	50 – 150	0.05 – 0.15	0.02 – 0.15
Keramik ungesintert	100 – 500	0.05 – 0.25	0.02 – 0.30

Einsatzbedingungen

- Schneiden nie mechanisch vermessen (Ausbruchgefahr).
- Möglichst hohe Schnittwerte anstreben, um so die Reibung zu reduzieren und dadurch die Standzeit der WEISS-Vielzahnfräser zu erhöhen



WEISS-Vielzahnfräser mit DIAPACT (PKD)-Schneiden (rechtsdrehend)

■ Mit HM-Schaft

Typ 2904

Schneidenzahl	Abmessungen					Typ
	ØD [mm]	Ød [mm]	Ød1 [mm]	l [mm]	l1 [mm]	
2	1.0	3.0	0.7	35	3	2904 WVZ-1.00 A055
	2.0	3.0	1.5	35	6	2904 WVZ-2.00 A056
4	3.0	3.0	2.5	35	9	2904 WVZ-3.00 A056
	4.0	4.0	3.5	40	12	2904 WVZ-4.00 A056
5	5.0	5.0	4.5	50	15	2904 WVZ-5.00 A056
6	6.0	6.0	5.5	60	20	2904 WVZ-6.00 A056
	8.0	8.0	7.5	65	25	2904 WVZ-8.00 A056
8	10.0	10.0	9.5	70	30	2904 WVZ-10.00 A056
	12.0	12.0	11.5	70	30	2904 WVZ-12.00 A056

Bestellinformationen

Verfügbare Ausführungen

DIAPACT(PKD)

Bestell-Code

A055 / A056

Verfügbarkeit

○

○ Auf Anfrage, bitte Wunschtermin für die Lieferung angeben

Bestellbeispiel:

■ 2904 WVZ-2.00 A056



Produktspektrum

DIAPACT(PKD)-Aufsteckfräser Typ 3000

→ Seite 2-19

Vorteile im Überblick

- Keine Montage von Schneidplatten
- kompakte Bauweise
- keine Montage- oder Einstellfehler
- genauer Planlauf
- exakter Rundlauf

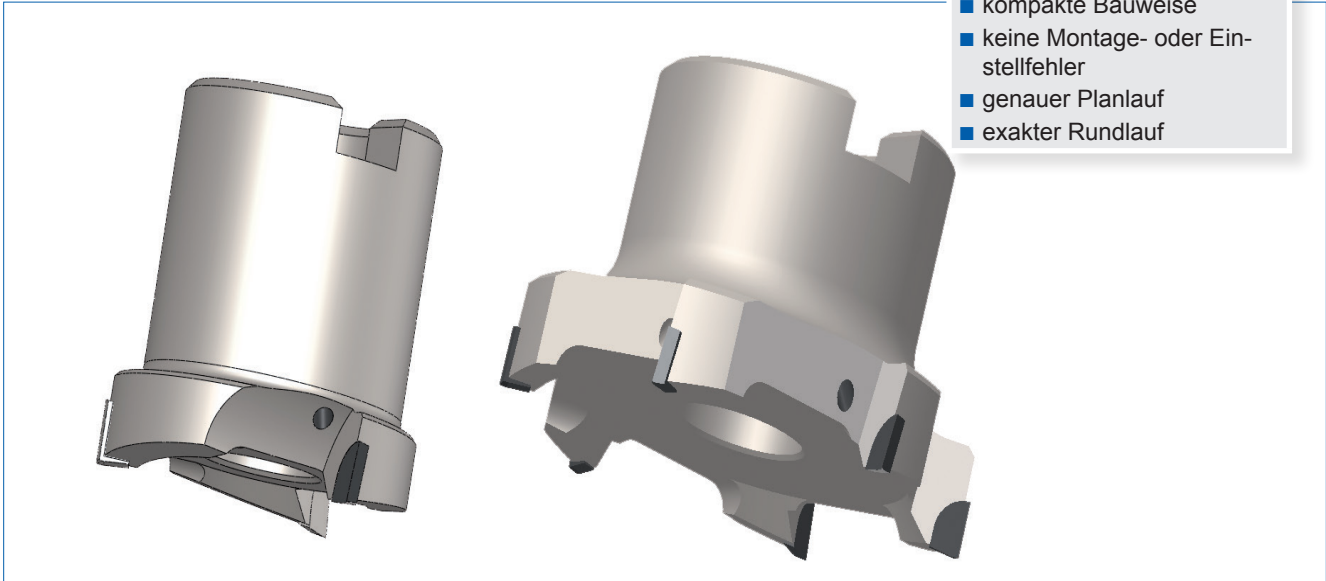

Produktmerkmale

- DIAPACT(PKD)-Rohlinge hartgelötet auf Träger
- nachschleif- oder nacherodierbar
- hohe Zähnezahl
- Einsatz bei Schrupp- und Schlichtbearbeitung
- Kühlung auf alle Schneiden möglich

Anwendungsbereiche

Schrupp- und Schlichtbearbeitung von Werkstücken aus Aluguss und Aluvollmaterial.

Durch die fest eingelöteten PKD-Schneiden sind bis zu Schnitttiefen von 5mm möglich.

Wegen der positiven Schneidengeometrie sind auch bei einer reduzierten Maschinenleistung hervorragende Zerspanraten zu erzielen.

Der PKD-bestückte Aufsteckfräser ist einem vergleichbaren Werkzeug mit Wendeschneidplatten-Bestückung in allen Belangen überlegen und lässt sich ganz einfach nachschleifen oder nacherodieren.

Drehzahlbereich: 8.000 -12.000 U / min

Vorschubbereich: 0.3 - 0.6 mm / U

Einsatzbedingungen

- Schneiden nie mechanisch vermessen (Ausbruchgefahr).
- Möglichst hohe Schnittwerte anstreben, um so die Reibung zu reduzieren und dadurch die Standzeit der Aufsteckfräser zu erhöhen



DIAPACT(PKD)-Aufsteckfräser 90° mit Kühlbohrung

- PKD direkt aufgelötet

Typ 3000

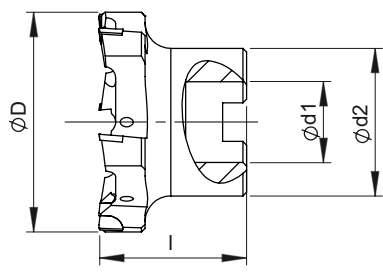
	Schneidenzahl	Abmessungen			Typ
		ØD [mm]	l [mm]	Ød1 [mm]	
3	40	40	16	3000-40-3 A0..	
	40	40	16	3000-40-4 A0..	
4	50	40	22	3000-50-4 A0..	
	50	40	22	3000-50-5 A0..	
5	63	40	22	3000-63-5 A0..	
	63	40	22	3000-63-6 A0..	
6	80	50	27	3000-80-6 A0..	

Bestellinformationen

Verfügbare Ausführungen	DIAPACT(PKD)					CVD-Diam.
	A010	A020	A030	A040	A041	A060
Bestell-Code						
Verfügbarkeit	<input type="radio"/>	<input type="radio"/>	<input type="radio"/>	<input type="radio"/>	<input type="radio"/>	<input type="radio"/>
	→ Seite 1-6					→ S 1-7

○ Auf Anfrage, bitte Wunschtermin für die Lieferung angeben

Bestellbeispiel für:
 Typ: 3000-63-6 A0..
 Ausführung: A010

- 3000-63-6 A010
- tt.mm.jj (Wunschtermin)



Produktspektrum

DIAPACT(PKD)-Scheibenfräser Typ 6000

→ Seite 2-21

Vorteile im Überblick

- Keine Montage von Schneidplatten
- kompakte Bauweise
- keine Montage- oder Einstellfehler
- genauer Planlauf
- exakter Rundlauf

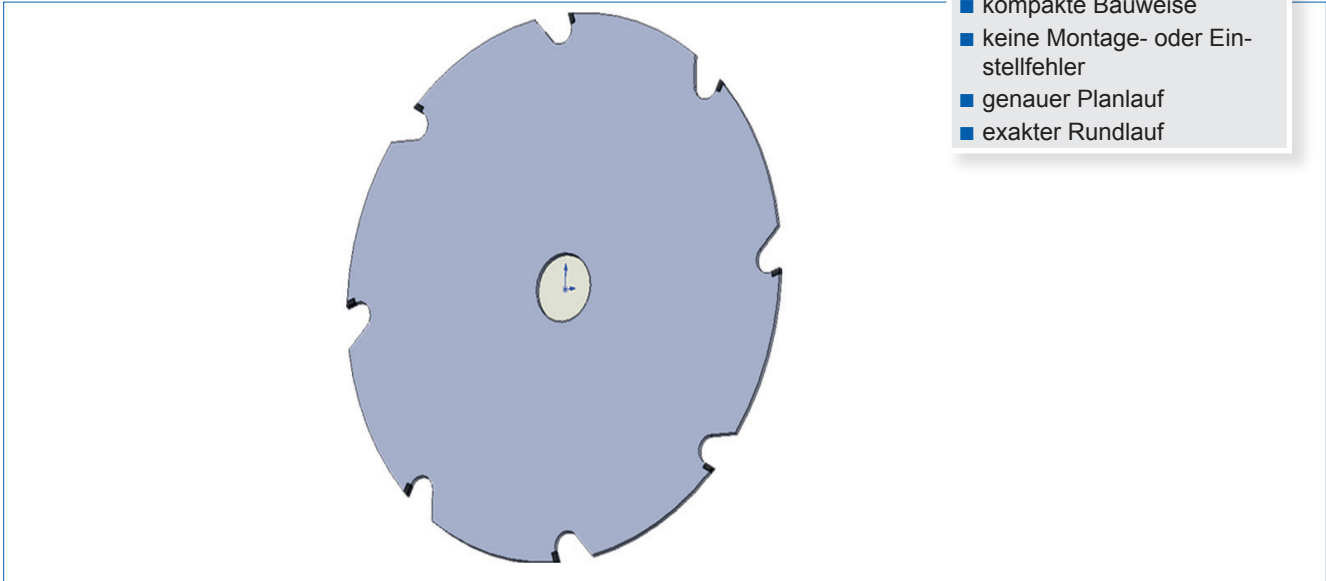

Produktmerkmale

- DIAPACT(PKD)-Rohlinge hartgelötet auf Träger
- nachschärfbar
- hohe Zähnezahl
- Einsatz beim Trennen von Kunststoff (GFK oder CFK)

Anwendungsbereiche

Trennen oder Schlitten von Glasfaser- und Kohlefaser Werkstücken.

Wegen der positiven Schneidengeometrie sind auch bei einer reduzierten Maschinenleistung hervorragende Zerspanraten zu erzielen.

Der PKD-bestückte Scheibenfräser ist einem vergleichbaren Werkzeug mit Hartmetallbestückung in allen Belangen überlegen und lässt sich ganz einfach schärfen oder neu bestücken.

Drehzahlbereich: 1.000 -3.000 U / min

Vorschubbereich: 0.05 - 0.1 mm / U

Einsatzbedingungen

- Schneiden nie mechanisch vermessen (Ausbruchgefahr).
- Möglichst hohe Schnittwerte anstreben, um so die Reibung zu reduzieren und dadurch die Standzeit der Scheibenfräser zu erhöhen
- Einsatz von Kühlschmierstoffen erhöht die Lebensdauer



DIAPACT(PKD)-Scheibenfräser

- DIAPACT(PKD) direkt aufgelötet

Typ 6000

Schneidenzahl	Abmessungen			Typ
	ØD [mm]	b [mm]	Ød1 [mm]	
4	160	1.6	20	6000-160-1.6-20-4 A020
		2.2		6000-160-2.2-20-4 A020
		2.5		6000-160-2.5-20-4 A020
		3.0		6000-160-3.0-20-4 A020
8	160	1.6	30	6000-160-1.6-20-8 A020
		2.2		6000-160-2.2-20-8 A020
		1.6		6000-160-1.6-30-8 A020
		2.2		6000-160-2.2-30-8 A020

Bestellinformationen

Verfügbare Ausführungen

DIAPACT(PKD)

Bestell-Code

A020

Verfügbarkeit

●

→ Seite 1-6

Bestellbeispiel für:

Typ: 6000-160-2.2-20-8 A020

Ausführung: A020

6000-160-2.2-20-8 A020

■ tt.mm.jj (Wunschtermin)



Produktspektrum

Fingerfräser mit BORAPACT (CBN)-Schneiden
Fräskopfeinsätze mit BORAPACT (CBN)-Schneiden
Fräskopfeinsätze mit Diamant-Schneiden
Fräsköpfe für Fräskopfeinsätze 2873

→ Seite 2-23
→ Seite 2-24
→ Seite 2-25
→ Seite 2-26

Vorteile im Überblick

- Bearbeitung von grossen Flächen
- Einfache und kostengünstige Lösung
- Einfache Handhabung



Produktmerkmale

- Werkzeugaufnahmen für Diamant- oder CBN-bestückte Einsätze.
- Einsätze hart- oder vakuumgelötet auf Stahlträger.

Anwendungsbereiche

- Überfräsen von grossen Flächen.

Einsatzbedingungen

- Schneiden nie mechanisch vermessen (Ausbruchgefahr).
- Fräskopfeinsätze vor Schneidenbruch nachschleifen lassen.
- Für unterbrochenen Schnitt die Schnittwerte ca. halbieren.
- Intensive Kühlung mit leichter Bohremulsion verbessert die Schnittleistung erheblich.
- Möglichst hohe Schnittwerte anstreben, um so die Reibung zu reduzieren und dadurch die Standzeit der Werkzeuge zu erhöhen.



Fingerfräser mit BORAPACT (CBN)-Schneiden (rechtsdrehend)

- Für Aussenbearbeitung
- Anwendung **Überfräsen**

B2871 Fingerfräser

	Schneidenzahl und Ausführung	Abmessungen						Typ
		ØD+0.5 [mm]	Ød [mm]	l [mm]	l1-0.2 [mm]	l2 [mm]	r [mm]	
einschneidig, ohne Zentrumschnitt	6	6	60	4.5	–	0.4	B 2871-6 B0..	
	8	6	60	4.5	10	0.4	B 2871-8 B0..	
	10	8	60	4.5	10	0.4	B 2871-10 B0..	
	12	10	80	8	15	0.8	B 2871-12 B0..	
	14	10	80	8	15	0.8	B 2871-14 B0..	
	16	12	80	8	15	0.8	B 2871-16 B0..	
	18	14	100	8	20	0.8	B 2871-18 B0..	
	20	16	100	8	20	1.2	B 2871-20 B0..	
	25	20	100	8	20	1.2	B 2871-25 B0..	

Typ B2876 mit HM-Schaft

	Schneidenzahl und Ausführung	Abmessungen					Typ
		ØD [mm]	Ød [mm]	l [mm]	l1 [mm]	l2 [mm]	
zweischneidig, ohne Zentrumschnitt	6	6	60	6	15	B2876-6 B0..	
	8	8	65	6	20	B2876-8 B0..	
	10	10	70	6	25	B2876-10 B0..	
	12	12	70	6	25	B2876-12 B0..	

Bestellinformationen

Verfügbare Ausführungen

	BORAPACT(CBN)			
	B010	B020	B040	B050
Bestell-Code	B010	B020	B040	B050
Verfügbarkeit	✓	○	○	○
Weitere Infos	→ Seite 1-5			

✓ Auf Lager ○ Auf Anfrage, bitte Wunschtermin für die Lieferung angeben

Bestellbeispiel für:

Typ: B 2871-10 B0..
Ausführung: BORAPACT B040

- B 2871-10 B040
- tt.mm.jj (Wunschtermin)



Fräskopfeinsätze

Mit BORAPACT (CBN)-Schneiden

Fräskopfeinsätze mit BORAPACT (CBN)-Schneiden (rechtsdrehend)

Typ 2873

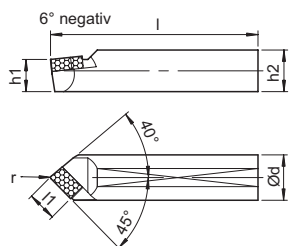

passend für Fräskopf	Ød [mm]	l [mm]	Abmessungen				Typ
			l1-0.2 [mm]	h1 [mm]	h2 [mm]	r [mm]	
2872-25	10	40	8	8	9	0.8	B 2873-10 B0..
2872-30	12	50	8	10	11	0.8	B 2873-12 B0..
2872-40	14	60	8	12	13	0.8	B 2873-14 B0..
2872-50	16	75	8	14	15	0.8	B 2873-16 B0..

Bestellinformationen

Verfügbare Ausführungen

Bestell-Code	BORAPACT(CBN)			
	B010	B020	B040	B050
Verfügbarkeit	✓	○	○	○
Weitere Infos	→ Seite 1-5			

✓ Auf Lager ○ Auf Anfrage, bitte Wunschtermin für die Lieferung angeben

Bestellbeispiel für:

Typ: B 2873-10 B0..
Ausführung: BORAPACT B040

- B 2873-10 B040
- tt.mm.jj (Wunschtermin)



Fräskopfeinsätze mit Diamant-Schneiden (rechtsdrehend)

Typ 2873

	passend für Fräskopf	Abmessungen						Typ
		Ød [mm]	l [mm]	l1 [mm]	h1 [mm]	h2 [mm]	r [mm]	
	2872-25	10	40	8	8	9	0.8	2873-10 A0..
	2872-30	12	50	8	10	11	0.8	2873-12 A0..
	2872-40	14	60	8	12	13	0.8	2873-14 A0..
	2872-50	16	75	8	14	15	0.8	2873-16 A0..

Bestellinformationen

Verfügbare Ausführungen	DIAPACT(PKD)					CVD-Diam.	MKD	Naturdiam.
	A010	A020	A030	A040	A041			
Bestell-Code	A010	A020	A030	A040	A041	A060	A070	A080
Verfügbarkeit	✓	○	○	○	○	○	○	○
Weitere Infos	→ Seite 1-6					→ Seite 1-7		

Auf Lager
 Auf Anfrage, bitte Wunschtermin für die Lieferung angeben

Bestellbeispiel für:
 Typ: 2873-10 A0..
 Ausführung: MKD

- 2873-10 A070
- l1 = 8 mm¹⁾
- tt.mm.jj (Wunschtermin)

¹⁾ Die Schneidkantenlänge l1 kann angegeben werden und sollte bei MKD- und Naturdiamant-Werkzeugen aus Kostengründen möglichst kurz gewählt werden.



Fräskopf

Für Fräskopfeinsatz 2873

Fräskopf für Fräskopfeinsatz 2873

Typ 2872

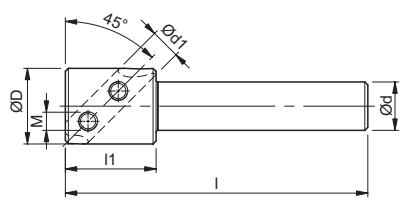
	passend für Fräskopfeinsatz	Abmessungen						Typ
		ØD [mm]	Ød [mm]	l [mm]	l1 [mm]	M [mm]	Ød1 [mm]	
	2873-10	25	16	100	30	6	10	2872-25
	2873-12	30	20	105	35	8	12	2872-30
	2873-14	40	25	115	45	8	14	2872-40
	2873-16	50	25	125	55	8	16	2872-50

Bestellinformationen

■ Fräskopf 2872-25





Produktspektrum

Fingerfräser mit Diamant-Schneiden
Radiusfräser mit Diamant-Schneiden

→ Seite 2-29
→ Seite 2-29

Vorteile im Überblick

- Engste Masstoleranzen und feinste Oberflächen
- Höchste Standzeiten
- Minimierte Ausschussraten
- Geringe oder keine Gratbildung
- Schaft h5 Qualität
- Innenkühlung



Produktmerkmale

- Diamant-Einsätze hartgelötet oder vakuumgelötet
- Innenkühlung
- Hartmetallschaft in h5 Toleranz
- DIAPACT Sorte A041 (verschleissfeste PKD Sorte)

Anwendungsbereiche

Werkzeuge mit Diamantschneiden erzielen hervorragende Ergebnisse im Hinblick auf Standzeit, Oberflächengüten sowie Produktionszeiten und sind somit vor allem geeignet bei hohen Stückzahlen oder bei hohem Werkzeugverschleiss.

Durch die hohe Abriebfestigkeit ergeben sich sehr lange Nutzungszeiten der Werkzeuge und somit geringe Stillstandzeiten der Produktionsmaschinen.

DIAPACT(PKD)-Fräser	CVD-Diamant-Fräser
Al-Si-Legierungen bis 20 % Si	Al-Si-Legierungen ab 13 % Si
Keramik ungesintert und gesintert	MMCs
Kupferlegierungen	GFK/Grafit
GFK/CFK	Wolfram
Hartmetalle ungesintert und gesintert	Thermoplast mit Kohlefaser, Teflon mit hohem Glasanteil

Einsatzbedingungen

- Schneiden nie mechanisch vermessen (Ausbruchgefahr).
- Fräser vor Schneidenbruch nachschleifen lassen.
- Für unterbrochenen Schnitt die Schnittwerte ca. halbieren.
- Intensive Kühlung mit leichter Bohremulsion verbessert die Schnittleistung erheblich.
- Möglichst hohe Schnittwerte anstreben, um so die Reibung zu reduzieren und dadurch die Standzeit der Fräser zu erhöhen.



Fingerfräser mit DIAPACT(PKD)-Schneiden (rechtsdrehend)

Typ D4000 DIAPACT-Ausführung mit Innenkühlung

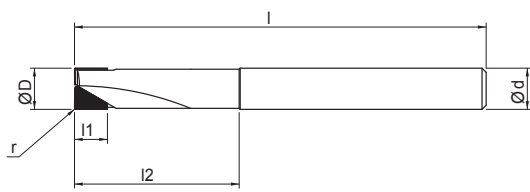

Z=	Abmessungen						Bezeichnung
	ØD [mm]	r [mm]	Ød [mm]	l [mm]	l1 [mm]	l2 [mm]	
1	4	0.2	4	80	4	25	D4000-04-A041
	5		5	80	5	25	D4000-05-A041
2	6		6	100	6	30	D4000-06-A041
	8		8	100	7	30	D4000-08-A041
	10		10	100	8	40	D4000-10-A041
	12		12	120	10	50	D4000-12-A041

Radiusfräser mit DIAPACT(PKD)-Schneiden (rechtsdrehend)

Typ D4100 DIAPACT(PKD)-Ausführung mit Innenkühlung

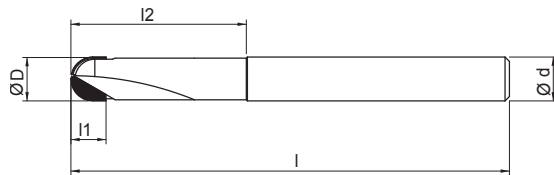

Z=	Abmessungen					Bezeichnung
	ØD/R [mm]	Ød [mm]	l [mm]	l1 [mm]	l2 [mm]	
1	4/2	4	80	4	25	D4100-04-A041
	5/2.5	5	80	5	25	D4100-05-A041
2	6/3	6	100	6	30	D4100-06-A041
	8/4	8	100	7	30	D4100-08-A041
	10/5	10	100	8	40	D4100-10-A041
	12/6	12	120	10	50	D4100-12-A041

Bestellinformationen

Verfügbare Ausführungen

Bestell-Code
Verfügbarkeit
Weitere Infos

DIAPACT(PKD)

A041

✓

→ Seite 1-6

✓ Auf Lager ○ Auf Anfrage, bitte Wunschtermin für die Lieferung angeben

andere DIAPACT (PKD)-Sorten auf Anfrage

Bestellbeispiel für:

Typ:D4100-08 A041

- D4100-08-A041
- tt.mm.jj (Wunschtermin)

Die Schneidkantenlänge l1 kann angegeben werden und sollte bei MKD- und Naturdiamant-Werkzeugen aus Kostengründen möglichst kurz gewählt werden.



Finger- und Radiusfräser mit gelaserten CVD-Diamant-Schneiden

Mit HM-Schaft | Innenkühlung | ein- und zweiseitig

Fingerfräser mit CVD-DIAMANT-Schneiden (rechtsdrehend)

Typ C4000 CVD-DIAMANT-Ausführung mit Innenkühlung

Z=	Abmessungen						Bezeichnung
	ØD [mm]	r [mm]	Ød [mm]	l [mm]	l1 [mm]	l2 [mm]	
1	4	0.2	4	80	4	25	C4000-04-A060
	5		5	80	5	25	C4000-05-A060
2	6		6	100	6	30	C4000-06-A060
	8		8	100	7	30	C4000-08-A060
	10		10	100	8	40	C4000-10-A060
	12		12	120	10	50	C4000-12-A060

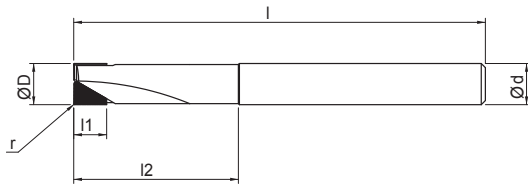

Radiusfräser mit CVD-DIAMANT-Schneiden (rechtsdrehend)

Typ C4100 CVD-DIAMANT-Ausführung mit Innenkühlung

Z=	Abmessungen					Bezeichnung
	ØD/R [mm]	Ød [mm]	l [mm]	l1 [mm]	l2 [mm]	
1	4/2	4	80	4	25	C4100-04-A060
	5/2.5	5	80	5	25	C4100-05-A060
2	6/3	6	100	6	30	C4100-06-A060
	8/4	8	100	7	30	C4100-08-A060
	10/5	10	100	8	40	C4100-10-A060
	12/6	12	120	10	50	C4100-12-A060

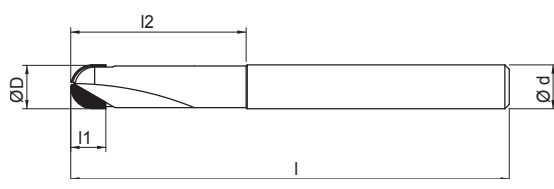

Bestellinformationen

Verfügbare Ausführungen

	CVD-DIAMANT
Bestell-Code	A060
Verfügbarkeit	✓
Weitere Infos	→ Seite 1-7

✓ Auf Lager ○ Auf Anfrage, bitte Wunschtermin für die Lieferung angeben

Bestellbeispiel für: Typ: C4100-08 A060

- C4100-08-A060
- tt.mm.jj (Wunschtermin)

Die Schneidkantenlänge l1 kann angegeben werden und sollte bei MKD- und Naturdiamant-Werkzeugen aus Kostengründen möglichst kurz gewählt werden.





Produktspektrum

CVD-Diamant mit gelaserten Schneiden

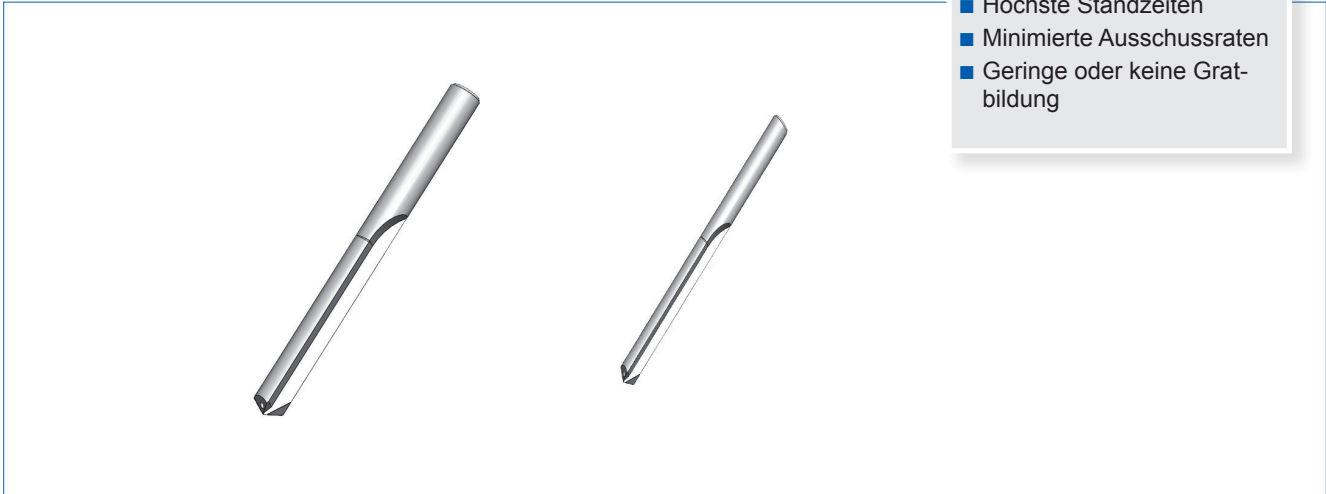

Vorteile im Überblick

- Engste Masstoleranzen und feinste Oberflächen
- Höchste Standzeiten
- Minimierte Ausschussraten
- Geringe oder keine Gratbildung

Produktmerkmale

- CVD-Diamant Einsätze vakuum gelötet
- Innenkühlung
- Gelaserte Diamantschneiden
- Hartmetallschaft h5 Toleranz
- CVD-Diamant mit polierter Spanfläche

Anwendungsbereiche

Werkzeuge mit Diamantschneiden erzielen hervorragende Ergebnisse im Hinblick auf Standzeit, Oberflächengüten sowie Produktionszeiten und sind somit vor allem geeignet bei hohen Stückzahlen oder bei hohem Werkzeugverschleiss.

Durch die hohe Abriebfestigkeit ergeben sich sehr lange Nutzungszeiten der Werkzeuge und somit geringe Stillstandzeiten der Produktionsmaschinen.

CVD-Diamant-Bohrer

Al-Si-Legierungen ab 13 % Si

MMCs

GFK/Grafit

Wolfram

Thermoplast mit Kohlefaser,
Teflon mit hohem Glasanteil

Einsatzbedingungen

- Schneiden nie mechanisch vermessen (Ausbruchgefahr).
- Fräser vor Schneidenbruch nachschleifen lassen.
- Für unterbrochenen Schnitt die Schnittwerte ca. halbieren.
- Intensive Kühlung mit leichter Bohremulsion verbessert die Schnittleistung erheblich.
- Möglichst hohe Schnittwerte anstreben, um so die Reibung zu reduzieren und dadurch die Standzeit der Fräser zu erhöhen.



CVD-DIAMANT Bohrer mit Innenkühlung

Typ C4600 mit Innenkühlung

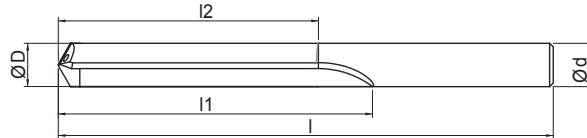

Abmessungen					
ØD [mm]	Ød [mm]	l [mm]	l1 [mm]	l2 [mm]	TYP
3.0	6	85	30	20	C4600-3.0-A060
3.3		85	30	20	C4600-3.3-A060
4.0		85	34	24	C4600-4.0-A060
4.2		85	46	36	C4600-4.2-A060
5.0		85	46	36	C4600-5.0-A060
5.5		85	46	36	C4600-5.5-A060
6.0	8	85	46	36	C4600-6.0-A060
6.8		98	58	48	C4600-6.8-A060
8.0		98	58	48	C4600-8.0-A060
8.5	10	115	70	60	C4600-8.5-A060
10		115	70	60	C4600-10.0-A060
10.2	12	137	87	72	C4600-10.2-A060
12.0		137	87	72	C4600-12.0-A060

Bestellinformationen

Verfügbare Ausführungen

A060

Verfügbarkeit

○

Weitere Infos

→ Seite 1-7

Auf Lager Auf Anfrage, bitte Wunschtermin für die Lieferung angeben
andere Abmessungen auf Anfrage

Bestellbeispiel für:

Typ: C4600 Ø8mm

- C4600-8.0-A060
- tt.mm.jj (Wunschtermin)



Produktspektrum

Glanzfräser Typ 5000 (ein- oder mehrschneidig)

→ Seite 2-35

Vorteile im Überblick

- Keine Montage von Schneidplatten
- kompakte Bauweise
- Fräskopf voreingestellt
- Wechselsystem
- Schrupp- und Schlicht- Bearbeitung in einem

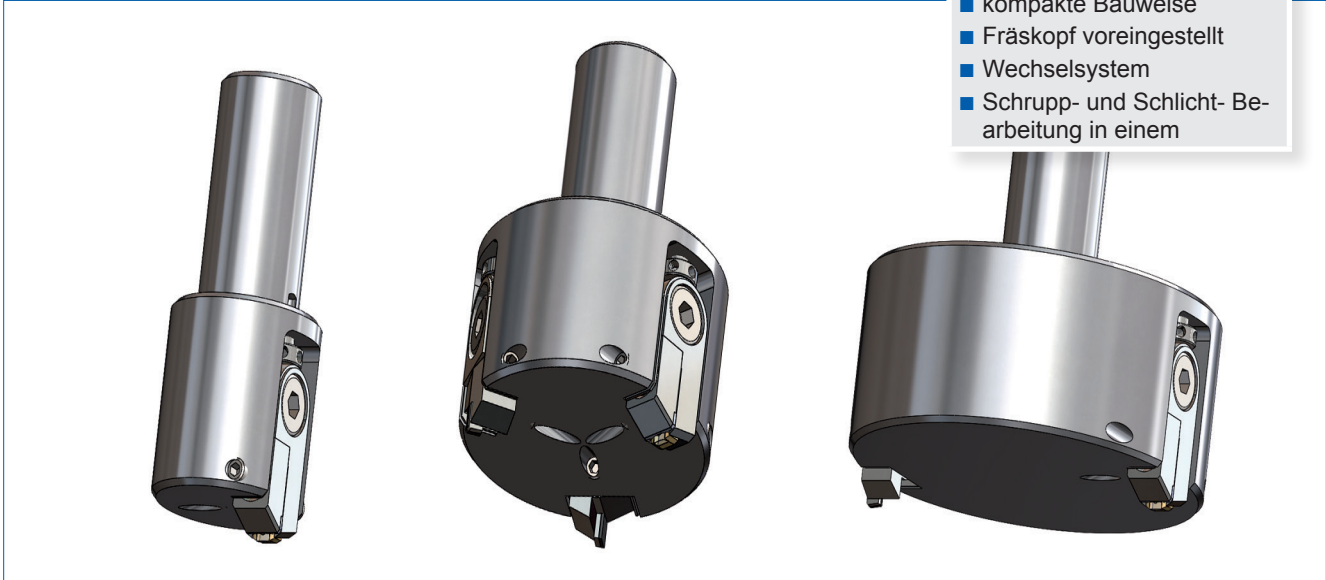

Produktmerkmale

- MKD oder Naturdiamant in Schneidkassetten
- nachschleifbar
- Zähne einzeln verstellbar

Anwendungsbereiche

Diese Werkzeuge werden eingesetzt um sehr hohe Oberflächengüten zu erreichen.

Haupteinsatzgebiete:

- Plexiglas
- Aluminium
- Messing

Drehzahlbereich: 1500 - 8000 U / min (Maschinen und Materialabhängig)

Vorschubbereich: 0.02 - 0.05 mm / U

Einsatzbedingungen

- Schneiden nie mechanisch vermessen (Ausbruchgefahr).
- Durch Ausrichten der Schneiden kann die Oberflächengüte erhöht werden
- Um eine hohe Oberflächengüte zu erreichen, muss das Werkzeug zwingend ausgewuchtet werden
- Oberflächengüte und Drehzahl angleichen
- Kühlung
- stabile, schwingungsfreie Maschine



Fräskopf Typ 5000

Typ 5000

Schneiden	Abmessungen			Typ
	ØD [mm]	l [mm]	Ød [mm]	
2	30	78	20	5000-30-2
2	50		20	5000-50-2
3	50		20	5000-50-3
2	60		20	5000-60-2
3	60		20	5000-60-3
2	75		20	5000-75-2
3	75		20	5000-75-3
3	110		20	5000-110-3

Schruppschneide Typ 5010 in DIAPACT (PKD)-Ausführung

Typ 5010

l [mm]	Abmessungen		Typ
	b [mm]	h [mm]	
28.5	8	12	5010 A010

Schlichtschneide Typ 5020 in MKD- oder Naturdiamant-Ausführung

Typ 5020

l [mm]	Abmessungen		Typ
	b [mm]	h [mm]	
28.5	8	12	5020 A070
28.5	8	12	5020 A080

Bestellinformationen

Verfügbare Ausführungen	DIAPACT(PKD)	MKD-Diamant	Natur-Diamant
	Bestell-Code	A010	A070
Verfügbarkeit	○ → Seite 1-6	○ → Seite 1-7	○ → Seite 1-7

Bestellbeispiel für:
 Typ: 5000 Ø60
 Ausführung: 2-Schneiden

- Grundkörper: 5000-60-2
- Schrumpfschneide: 5010 A010
- Schlichtschneide: 5020 A080
- tt.mm.jj (Wunschtermin)

○ Auf Anfrage, bitte Wunschtermin für die Lieferung angeben



Stehende Abrichtwerkzeuge

DIAROLL-Diamantabrichter

- Produktübersicht 3-2
- Abrichter für Rund- und Flachscheifen 3-3
- Abrichter für Innenschleifen 3-5
- Abrichter für Profilscheifen 3-6
- Halterbeispiele für DIAROLL-Geräte 3-7

DIALETTEN-Diamantabrichter

- Produktübersicht DIALETTEN-Abrichter 3-8
 - Anwendung 3-9
- DIALETTEN-Abrichter mit Nadel-Diamanten 3-10
- DIALETTEN-Abrichter mit Körnungs-Diamanten 3-12
- Produktübersicht DIALETTEN-Abrichter mit MKD- und CVD-Diamant 3-14
 - Anwendungsbereiche 3-15
- DIALETTEN-Abrichter mit MKD
 - Normal-DIALETTEN 3-16
 - Doppel-DIALETTEN 3-18
 - Quattro-DIALETTEN 3-19
- DIALETTEN-Abrichter mit CVD-Diamant
 - Normal-DIALETTEN 3-20
 - Doppel-DIALETTEN 3-22
 - Quattro-DIALETTEN 3-23
- Halterbeispiele für DIALETTEN-Abrichter 3-24

Vielkornabrichter

- Produktübersicht 3-28
- Y-Diamantabrichter YA 3-29
- Diamant-Vielkornabrichter VA 3-30
- Diamant-Aggregate AGD 3-33
- Halterbeispiele für Diamant-Aggregate AGD 3-34

Abrichtleisten

- Produktübersicht 3-36
- Diamant-Abrichtleisten 3-37

Handabrichter

- Produktübersicht 3-38
- Diamant-Handabrichter HAB 3-39

Einkornabrichter

- Produktübersicht Einkornabrichter mit Naturdiamanten 3-40
- Einweg-Abrichtdiamanten 3-41
 - Richtlinien für den Einsatz von Einkorndiamanten 3-41
- Produktübersicht Einkornabrichter mit MKD- und CVD-Diamanten 3-44
- MKD- und CVD-Diamant-Einkornabrichter 3-45
- Halterbeispiele für Einkornabrichter 3-46

Dreieckabrichter

- Produktübersicht 3-50
- Dreieckabrichter mit DIAPACT(PKD) 3-51
- Dreieckabrichter mit CVD-Diamant 3-52
- Halterbeispiele für Dreieckabrichter 3-53
- Aufnahmen für Dreiecksabrichter 3-54

Profilabrichter

- Produktübersicht neue MKD-Profilabrichter 3-54
- Halter für neue MKD-Profilabrichter 3-55
- Profilabrichter mit neuem MKD-Diamant 3-56
- Aufnahmen für Profilabrichter 3-59
- Produktübersicht 3-58
- Halter für Profilabrichter 3-59
- Profilabrichter mit Naturdiamant 3-60
- Profilabrichter mit MKD-Diamant 3-61
- Profilabrichter mit CVD-Diamant 3-62
- Aufnahmen für Profilabrichter 3-65

Wendeplattenabrichter

- Produktübersicht 3-70
- Wendeplattenabrichter 3-71
- Aufnahmen für Wendeplattenabrichter 3-76

M-Dresser

- Produktübersicht 3-78
- M-Dresser Typen 3-79

Rotierende Abrichtwerkzeuge

WEISS DRESSER

- Produktübersicht 3-64
- DRESSER Abrichtgeräte 3-65
- DRESSER Abrichteinheiten 3-65
 - Diamant-Abrichträder 3-65
 - Diamant-Abrichttöpfe 3-66
- Zubehör und Ersatzteile 3-67

Abrichtwelle

- Produktübersicht 3-68
- Abrichtwelle für CBN- und Diamantscheiben 3-68



Produktspektrum

DIAROLL-Diamantabrichter
Haltebeispiele für DIAROLL-Geräte

→ Seite 3-3

→ Seite 3-7

Vorteile im Überblick

- Grosse Stabilität und Robustheit
- Kein Umfassen wie bei Einkorn-Abrichtdiamanten
- Geringe Lagerhaltungskosten
- Zeitersparnis (erhöhter Abrichtvorschub)
- Grosse Abrichtleistung, dadurch lange Lebensdauer
- Variierbare Griffigkeit der Schleifscheibe
- Günstiges Verhältnis zwischen Preis und Diamantgewicht

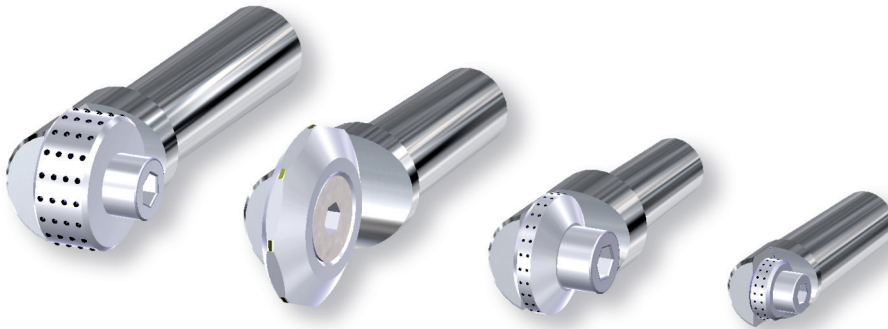

Produktmerkmale

- Handgesetzete Natur- oder synthetische Diamanten, in verschleissfestem Sintermetall eingebettet.
- Form, Grösse, Qualität und Gesamtgewicht der Diamanten je nach Typ und Anwendungsbereich verschieden.

Anwendungsbereiche

- Abrichten von Schleifscheiben in Korund-, Edelkorund- und Siliziumkarbid-Körnung mit keramischer und Kunstharzbindung.
- Auf Rund-, Innen-, Centerless- und Flachsleifmaschinen.
- Beim Einstech-, Pendel- und Profilschleifen.

Einsatzbedingungen

- **Hinweis: Kühlen ist sehr wichtig!**
- DIAROLL-Geräte kurz einspannen und fest anziehen.
- DIAROLL-Geräte so einspannen, dass die beiden Achsen Scheibe – DIAROLL parallel laufen.
- Abrichtzustellung beim Innenschleifen 0.01 mm, beim Rund- und Flachsleifen 0.02 – 0.03 mm.
- Bei zwei- und mehrreihigen DIAROLL-Geräten den Abrichtvorschub erhöhen, bis die Scheibe die gewünschte Griffigkeit aufweist.
- Zum Schruppschleifen Abrichtvorschub erhöhen, beim Feinschleifen Abrichtvorschub reduzieren.
- Je nach DIAROLL-Typ sollte die Kontaktfläche zur Schleifscheibe nie grösser als 2 – 6 mm werden. Ist diese Fläche entstanden, Schraube lösen, DIAROLL etwas weiterdrehen, dann Schraube wieder fest anziehen.



DIAROLL-Diamantabrichter für Rund- und Flachsleifen

Typ C

	Geeignet für Schleifscheiben			Diamantgewicht [Karat]	Typ
	Durchmesser [mm]	Breite [mm]	Körnung [µm]		
	bis 600	bis 100	36 – 46	2	C

Typ G

	Geeignet für Schleifscheiben			Diamantgewicht [Karat]	Typ
	Durchmesser [mm]	Breite [mm]	Körnung [µm]		
	bis 600	bis 100	54 – 80	2	G

Typ J

	Geeignet für Schleifscheiben			Diamantgewicht [Karat]	Typ
	Durchmesser [mm]	Breite [mm]	Körnung [µm]		
	bis 600	bis 100	80 – 150	2	J

Typ MC

	Geeignet für Schleifscheiben			Diamantgewicht [Karat]	Typ
	Durchmesser [mm]	Breite [mm]	Körnung [µm]		
	bis 1000	bis 300	36 – 46	5	MC

Typ MG

	Geeignet für Schleifscheiben			Diamantgewicht [Karat]	Typ
	Durchmesser [mm]	Breite [mm]	Körnung [µm]		
	bis 1000	bis 300	54 – 80	4.5	MG

Fortsetzung und Bestellbeispiel siehe nächste Seite



DIAROLL-Diamantabrichter für Rund- und Flachscheifen

Stehende Abrichtwerkzeuge

Typ MJ

	Geeignet für Schleifscheiben			Diamantgewicht [Karat]	Typ
	Durchmesser [mm]	Breite [mm]	Körnung [µm]		
	bis 1000	bis 300	80 – 150	4	MJ

Typ SM

	Geeignet für Schleifscheiben			Diamantgewicht [Karat]	Typ
	Durchmesser [mm]	Breite [mm]	Körnung [µm]		
	bis 1500	bis 600	36 – 46	14	SM

Typ B

	Geeignet für Schleifscheiben			Diamantgewicht [Karat]	Typ
	Durchmesser [mm]	Breite [mm]	Körnung [µm]		
	bis 300	bis 50	60 – 120	0.75	B

Typ F

	Geeignet für Schleifscheiben			Diamantgewicht [Karat]	Typ
	Durchmesser [mm]	Breite [mm]	Körnung [µm]		
	bis 300	bis 50	46 – 80	0.5	F

Typ ASS

	Geeignet für Schleifscheiben			Diamantgewicht [Karat]	Typ
	Durchmesser [mm]	Breite [mm]	Körnung [µm]		
	bis 600	bis 100	46 – 120	1	ASS

Bestellbeispiel

- DIAROLL MG
- Halterbeispiele → Seite 3-7



DIAROLL-Diamantabrichter für Innenschleifen

Typ H

	Geeignet für Schleifscheiben			Diamantgewicht [Karat]	Typ
	Durchmesser [mm]	Breite [mm]	Körnung [µm]		
	bis 150	bis 20	60 – 300	0.5	H

Typ Miniroll

	Geeignet für Schleifscheiben			Diamantgewicht [Karat]	Typ
	Durchmesser [mm]	Breite [mm]	Körnung [µm]		
	bis 100	bis 20	60 – 300	0.3	Miniroll

Bestellbeispiel

- DIAROLL Miniroll
- Halterbeispiele → [Seite 3-7](#)



DIAROLL-Diamantabrichter für Profilschleifen

Typ AS

	Geeignet für Schleifscheiben			Diamantgewicht [Karat]	Typ
	Durchmesser [mm]	Breite [mm]	Körnung [µm]		
	bis 600	bis 100	46 – 120	2	AS

Typ AZ

	Geeignet für Schleifscheiben			Diamantgewicht [Karat]	Typ
	Durchmesser [mm]	Breite [mm]	Körnung [µm]		
	bis 600	bis 100	80 – 150	2	AZ

Typ AR (CVD-Ausführung) Anwendung: weiche bis mittelharte Scheiben

	Geeignet für Schleifscheiben			Winkel a	Radius R	Typ
	Durchmesser [mm]	Breite [mm]	Körnung [µm]			
	bis 600	bis 100	46– 100	30°, 40°, 60°	0.1, 0.125, 0.2, 0.25, 0.3, 0.4	AR

Typ ASN

	Geeignet für Schleifscheiben			Diamantgewicht [Karat]	Typ
	Durchmesser [mm]	Breite [mm]	Körnung [µm]		
	bis 400	bis 50	60 – 120	1	ASN

Bestellbeispiel

- DIAROLL AR 30/125
- Halterbeispiele → Seite 3-7



Halterbeispiele für DIAROLL-Geräte

DIAROLL-Halter mit zylindrischem Schaft

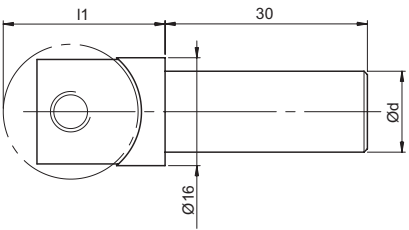
	Lieferbare Ausführungen Ød [mm]	Einbaumass l1 [mm] für DIAROLL-Gerät				
		B, H	C, F, G, J	MC, MG, MJ	AS, ASS, ASN, AZ	SM
	6 8 9 9.5 10 11 12 12.5 14 15	21	22	24	27	32

DIAROLL-Halter mit konischem Schaft

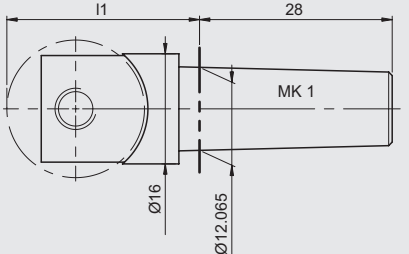
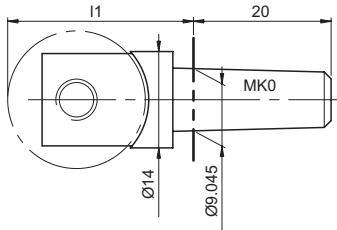
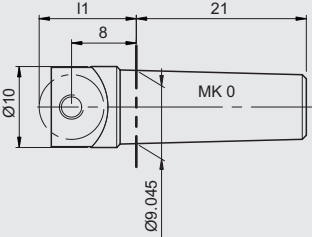
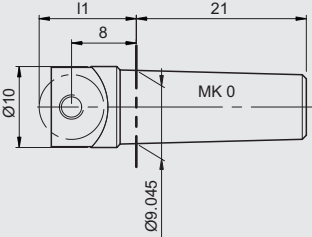
	Ausführung	Einbaumass l1 [mm] für DIAROLL-Gerät					
		B, H	C, F, G, J	MC, MG, MJ	AS, ASS, ASN, AZ, AR	SM	Miniroll
	Morse Konus 1	25	26	28	31	36	–
	Morse Konus 0	24	25	27	30	35	–
	Morse Konus 0			–			12

Bestellbeispiele

Halter mit zylindrischem Schaft:

- Halter zyl. Ø10 mm für DIAROLL H ¹⁾

Halter mit konischem Schaft:

- Halter Morse Konus 1 für DIAROLL MG ¹⁾

¹⁾Weitere Halter nach Angabe



Produktspektrum

Nadel-DIALETTEN (Typ Z und Typ P)

→ Seite 3-10

Körnungs-DIALETTEN (Typ Z und Typ P)

→ Seite 3-12

Produktübersicht MKD- und CVD-Diamant-DIALETTEN

→ Seite 3-14

■ MKD-DIALETTEN

→ Seite 3-16

■ CVD-Diamant-DIALETTEN

→ Seite 3-20

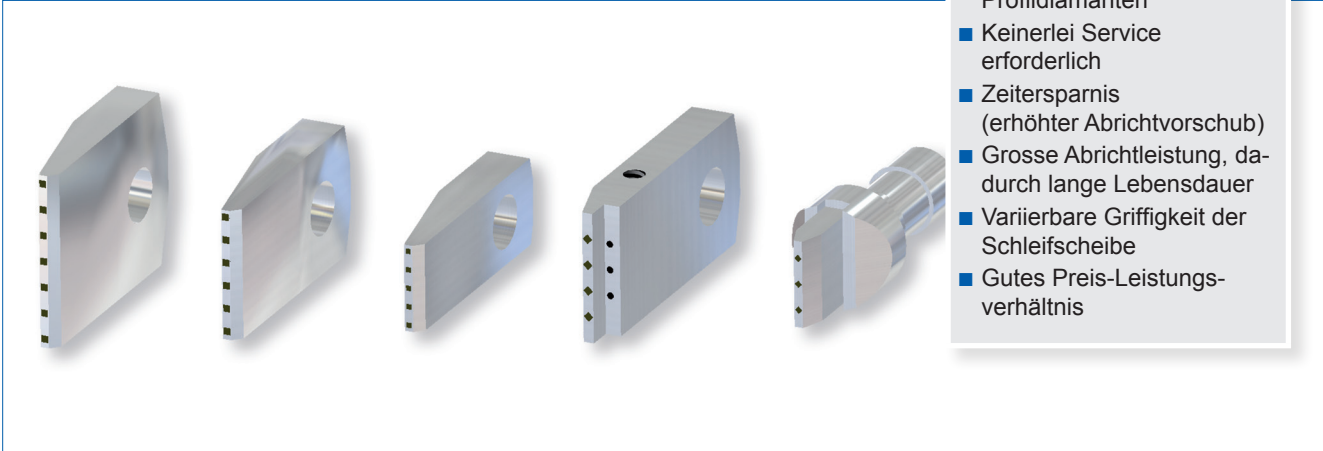

Vorteile im Überblick

- DIALETTEN ersetzen häufig teurere geschliffene Profildiamanten
- Keinerlei Service erforderlich
- Zeitersparnis (erhöhter Abrichtvorschub)
- Grosse Abrichtleistung, dadurch lange Lebensdauer
- Variierbare Griffigkeit der Schleifscheibe
- Gutes Preis-Leistungs-verhältnis

Produktmerkmale

- Handgesetzte, gestreute oder mittels Setzmuster angeordnete Natur- oder synthetische Diamanten, in verschleissfestem Sintermetall eingebettet.
- Sintermetall je nach Scheibenhärte und Scheibenart unterschiedlich.
- Diamantgrösse und -gewicht je nach Typ verschieden.
- DIALETTE je nach Anwendung oder Maschinentyp geklemmt oder direkt gelötet auf Halter einsetzbar.

Anwendungsbereiche

- Abrichten von Schleifscheiben in Korund-, Edelkorund- und Siliziumkarbid-Körnung mit keramischer und Kunstharzbindung.
- Auf Rund-, Centerless- und Flachsleifmaschinen.
- Beim Einstech-, Pendel- und Profilschleifen.

Einsatzbedingungen

- DIALETTE kurz einspannen und fest anziehen.
- Die Achse der DIALETTE sollte genau auf das Zentrum der Schleifscheibe ausgerichtet sein.
- Ausreichende Kühlung erhöht die Lebensdauer der DIALETTEN.

Einsatzparameter

- Abrichtzustellung: 0.02 – 0.03 mm
- Abrichtvorschub: 0.05 – 0.20 mm/U
Abhängig von Scheibenkörnung und gewünschter Oberfläche

- Mit zunehmender Diagonalstellung der DIALETTE kann:
1. Bei gleichbleibendem Abrichtvorschub eine feinere Oberfläche erzielt werden oder
 2. Bei gleichbleibender Oberflächengüte der Abrichtvorschub erhöht werden.

Hinweis: Hat sich die DIALETTE einmal der Schleifscheibe angepasst, sollte die Lage nicht mehr verändert werden.



Anwendung

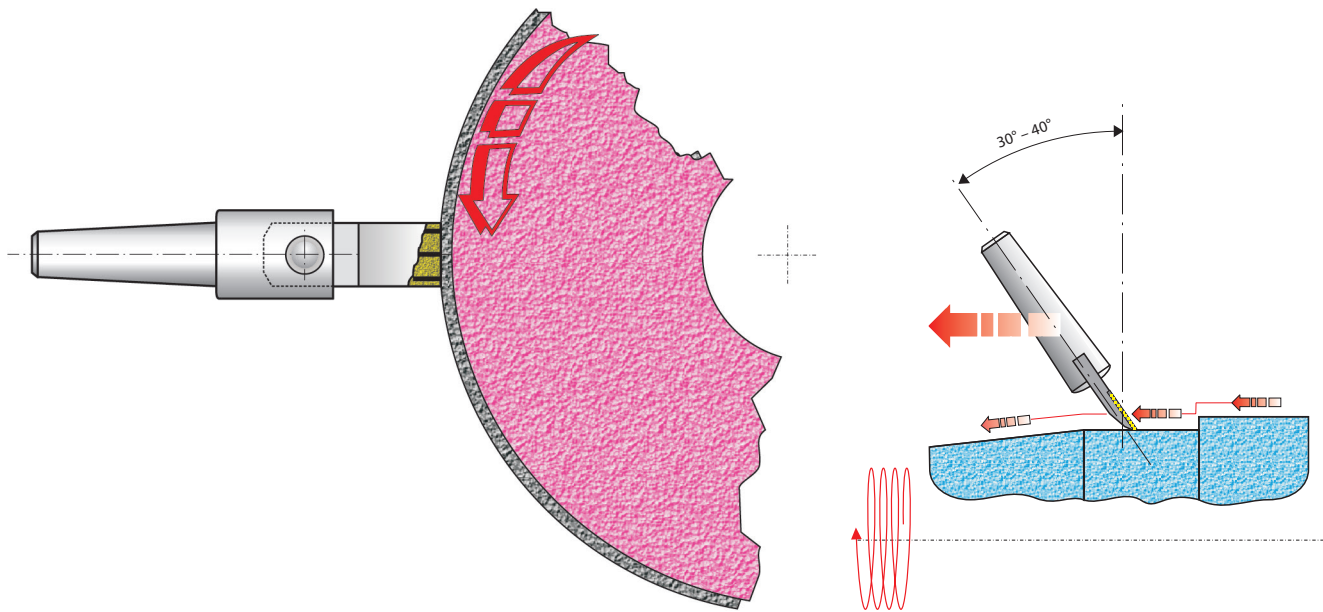

Wichtiger Hinweis

- Metallener DIALETTEN-Rücken muss in der Abriechbewegung immer zuvorderst sein, damit das Werkzeug freischneidet.
- Von Zeit zu Zeit die Diamanten wieder freistellen, indem man mit einer Zustellung von 0.1 mm und hohem Vorschub (ca. 500 bis 800 mm/min) mehrmals eine Schleifscheibe abriecht.

Vorschubformel für DIALETTEN-Abriecher

Der Abriechvorschub v_d in mm/min lässt sich mittels der nachstehenden Formel bestimmen:

$$v_d \text{ Normalschleifen} = \frac{n_s \times b_d}{4}$$

$$v_d \text{ Feinschleifen} = \frac{n_s \times b_d}{6}$$

Wenn Wirkbreite b_d (X-Mass) der Fliese nicht bekannt ist, dann eine Wirkbreite b_d von 0.9 mm in die Formel einsetzen.

b_d = Wirkbreite in mm

n_s = Drehzahl Schleifscheibe pro min

v_d = Abriechvorschub in mm/min



DIALETTEN-Abrichter mit Nadel-Diamanten Typ Z

Stehende Abrichtwerkzeuge

DIALETTEN-Abrichter mit Nadel-Diamanten in Normalausführung Typ Z

- Normalausführung Typ Z (Nadelqualität 1)
- Anwendung bei normalen Abrichtprozessen mit geringen Oberflächenanforderungen
- Für erhöhte Anforderungen wird die Präzisionsausführung Typ P empfohlen
- Erhältlich in vier Bindungsarten
- Zwei Längen lieferbar

Typ ZS

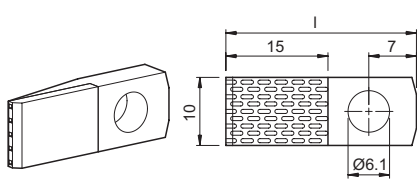
	Geeignet für Schleifscheiben				Typ
	Durchmesser [mm]	Breite [mm]	Körnung [µm]	Wirkbreite [mm]	
bis 500	bis 100	36 – 46	1.40	ZS 36 ...	
		46 – 60	1.15	ZS 46 ...	
		60 – 80	0.90	ZS 60 ...	
		80 – 150	0.85	ZS 80 ...	
		150 – 300	0.70	ZS 100 ...	

Typ ZM

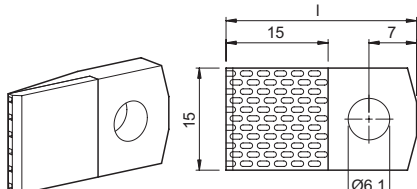
	Geeignet für Schleifscheiben				Typ
	Durchmesser [mm]	Breite [mm]	Körnung [µm]	Wirkbreite [mm]	
300 – 800	50 – 250	36 – 46	1.40	ZM 36 ...	
		46 – 60	1.15	ZM 46 ...	
		60 – 80	0.90	ZM 60 ...	
		80 – 150	0.85	ZM 80 ...	
		150 – 300	0.70	ZM 100 ...	

Typ ZB

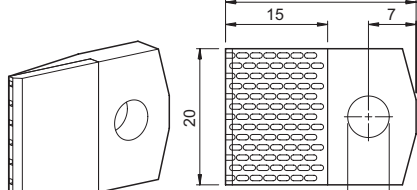
	Geeignet für Schleifscheiben				Typ
	Durchmesser [mm]	Breite [mm]	Körnung [µm]	Wirkbreite [mm]	
500 – 1500	100 – 600	36 – 46	1.40	ZB 36 ...	
		46 – 60	1.15	ZB 46 ...	
		60 – 80	0.90	ZB 60 ...	
		80 – 150	0.85	ZB 80 ...	
		150 – 300	0.70	ZB 100 ...	

Bestellinformationen

Verfügbare Ausführungen ¹⁾	Bindungsbezeichnung	Bindungsart	Anwendung / Scheibentyp
Bindung ²⁾	V	Kupferbindung	sehr weiche bis weiche Korundscheiben
	W25	Wolframbindung	weiche bis mittelharte Korundscheiben
	W	Wolframbindung	mittlere bis harte Korundscheiben
	U	Hartmetallbindung	Siliziumkarbidscheiben

	Ausführung K	Ausführung L
Länge l [mm]	28	33

¹⁾ Andere DIALETTEN auf Anfrage

²⁾ Andere Bindungen auf Anfrage

Bestellbeispiel für:

Typ: ZM 60 ...
Ausführung:
Kupferbindung, Länge 33 mm

- Nadel-DIALETTE
- ZM 60 V L

Halterbeispiele → Seite 3-24



DIALETTEN-Abrichter mit Nadel-Diamanten in Präzisionsausführung Typ P

- Präzisionsausführung Typ P (Nadelqualität „super“)
- Anwendung bei kontinuierlichen Abrichtprozessen und hohen Oberflächenanforderungen an das Werkstück
- Erhältlich in vier Bindungsarten
- Zwei Längen lieferbar

Typ PS

	Geeignet für Schleifscheiben				Typ
	Durchmesser [mm]	Breite [mm]	Körnung [µm]	Wirkbreite [mm]	
bis 500	bis 100	46 – 60	1.15	PS 46 ...	
		60 – 80	0.90	PS 60 ...	
		80 – 150	0.85	PS 80 ...	
		150 – 300	0.70	PS 100 ...	

Typ PM

	Geeignet für Schleifscheiben				Typ
	Durchmesser [mm]	Breite [mm]	Körnung [µm]	Wirkbreite [mm]	
300 – 800	50 – 250	46 – 60	1.15	PM 46 ...	
		60 – 80	0.90	PM 60 ...	
		80 – 150	0.85	PM 80 ...	
		150 – 300	0.70	PM 100 ...	

Typ PB

	Geeignet für Schleifscheiben				Typ
	Durchmesser [mm]	Breite [mm]	Körnung [µm]	Wirkbreite [mm]	
500 – 1500	100 – 600	46 – 60	1.15	PB 46 ...	
		60 – 80	0.90	PB 60 ...	
		80 – 150	0.85	PB 80 ...	
		150 – 300	0.70	PB 100 ...	

Bestellinformationen

Verfügbare Ausführungen ¹⁾	Bindungsbezeichnung	Bindungsart	Anwendung / Scheibentyp
Bindung ²⁾	V	Kupferbindung	sehr weiche bis weiche Korundscheiben
	W25	Wolframbindung	weiche bis mittelharte Korundscheiben
	W	Wolframbindung	mittlere bis harte Korundscheiben
	U	Hartmetallbindung	Siliziumkarbidscheiben

	Ausführung K	Ausführung L
Länge l [mm]	28	33

¹⁾ Andere DIALETTEN auf Anfrage

²⁾ Andere Bindungen auf Anfrage

Bestellbeispiel für:

Typ: PB 60 ...
Ausführung:
Kupferbindung, Länge 33 mm

- Nadel-DIALETTE
- PB 60 V L

Halterbeispiele → Seite 3-24



Körnungs-DIALETTEN in Normalausführung Typ Z

Stehende Abrichtwerkzeuge

DIALETTEN-Abrichter mit Diamantkörnung in Normalausführung Typ Z

- Normalausführung Typ Z (Diamanten handgesetzt)
- Anwendung bei normalen Abrichtprozessen mit geringen Oberflächenanforderungen
- Für erhöhte Anforderungen wird die Präzisionsausführung Typ P empfohlen
- Erhältlich in vier Bindungsarten
- Zwei Längen lieferbar

Typ ZS D

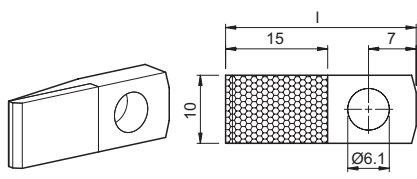
	Geeignet für Schleifscheiben				Typ
	Durchmesser [mm]	Breite [mm]	Körnung [µm]	Wirkbreite [mm]	
bis 500	bis 100	180 – 240	0.35	ZS D 356 ...	
		120 – 180	0.45	ZS D 501 ...	
		80 – 120	0.75	ZS D 711 ...	
		60 – 100	0.85	ZS D 852 ...	
		54 – 80	1.00	ZS D 1001 ...	
		36 – 54	1.20	ZS D 1181 ...	

Typ ZM D

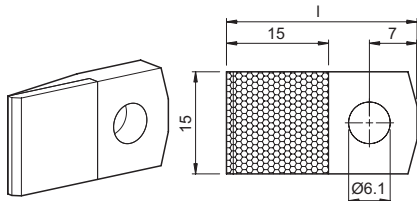
	Geeignet für Schleifscheiben				Typ
	Durchmesser [mm]	Breite [mm]	Körnung [µm]	Wirkbreite [mm]	
300 – 800	50 – 250	180 – 240	0.35	ZM D 356 ...	
		120 – 180	0.45	ZM D 501 ...	
		80 – 120	0.75	ZM D 711 ...	
		60 – 100	0.85	ZM D 852 ...	
		54 – 80	1.00	ZM D 1001 ...	
		36 – 54	1.20	ZM D 1181 ...	

Typ ZB D

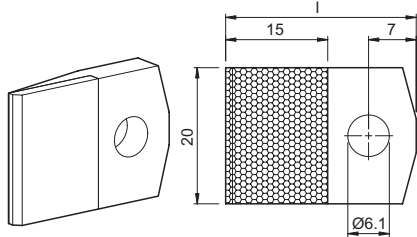
	Geeignet für Schleifscheiben				Typ
	Durchmesser [mm]	Breite [mm]	Körnung [µm]	Wirkbreite [mm]	
500 – 1500	100 – 600	180 – 240	0.35	ZB D 356 ...	
		120 – 180	0.45	ZB D 501 ...	
		80 – 120	0.75	ZB D 711 ...	
		60 – 100	0.85	ZB D 852 ...	
		54 – 80	1.00	ZB D 1001 ...	
		36 – 54	1.20	ZB D 1181 ...	

Bestellinformationen

Verfügbare Ausführungen ¹⁾	Bindungsbezeichnung	Bindungsart	Anwendung / Scheibentyp
Bindung ²⁾	V	Kupferbindung	sehr weiche bis weiche Korundscheiben
	W25	Wolframbindung	weiche bis mittelharte Korundscheiben
	W	Wolframbindung	mittlere bis harte Korundscheiben
	U	Hartmetallbindung	Siliziumkarbidscheiben

	Ausführung K	Ausführung L
Länge l [mm]	28	33

¹⁾ Andere DIALETTEN auf Anfrage

²⁾ Andere Bindungen auf Anfrage

Bestellbeispiel für:

Typ: ZS D 1001 ...
Ausführung:
Wolframbindung, Länge 28 mm

- Körnungs-DIALETTE
- ZS D 1001 W K

Halterbeispiele → Seite 3-24



DIALETTEN-Abrichter mit Diamantkörnung in Präzisionsausführung Typ P

- Präzisionsausführung Typ P (Diamanten gesetzt mittels Setzmuster)
- Anwendung bei kontinuierlichen Abrichtprozessen und hohen Oberflächenanforderungen an das Werkstück
- Erhältlich in vier Bindungsarten
- Zwei Längen lieferbar

Typ PS D

	Geeignet für Schleifscheiben				Typ
	Durchmesser [mm]	Breite [mm]	Körnung [µm]	Wirkbreite [mm]	
bis 500	bis 100	180 – 240	0.35	PS D 356 ...	
		120 – 180	0.45	PS D 501 ...	
		80 – 120	0.75	PS D 711 ...	
		60 – 100	0.85	PS D 852 ...	
		54 – 80	1.00	PS D 1001 ...	
		36 – 54	1.20	PS D 1181 ...	

Typ PM D

	Geeignet für Schleifscheiben				Typ
	Durchmesser [mm]	Breite [mm]	Körnung [µm]	Wirkbreite [mm]	
300 – 800	50 – 250	180 – 240	0.35	PM D 356 ...	
		120 – 180	0.45	PM D 501 ...	
		80 – 120	0.75	PM D 711 ...	
		60 – 100	0.85	PM D 852 ...	
		54 – 80	1.00	PM D 1001 ...	
		36 – 54	1.20	PM D 1181 ...	

Typ PB D

	Geeignet für Schleifscheiben				Typ
	Durchmesser [mm]	Breite [mm]	Körnung [µm]	Wirkbreite [mm]	
500 – 1500	100 – 600	180 – 240	0.35	PB D 356 ...	
		120 – 180	0.45	PB D 501 ...	
		80 – 120	0.75	PB D 711 ...	
		60 – 100	0.85	PB D 852 ...	
		54 – 80	1.00	PB D 1001 ...	
		36 – 54	1.20	PB D 1181 ...	

Bestellinformationen

Verfügbare Ausführungen ¹⁾	Bindungsbezeichnung	Bindungsart	Anwendung / Scheibentyp
Bindung ²⁾	V	Kupferbindung	sehr weiche bis weiche Korundscheiben
	W25	Wolframbindung	weiche bis mittelharte Korundscheiben
	W	Wolframbindung	mittlere bis harte Korundscheiben
	U	Hartmetallbindung	Siliziumkarbidscheiben
		Ausführung K	Ausführung L
Länge l [mm]	28		33

¹⁾ Andere DIALETTEN auf Anfrage

²⁾ Andere Bindungen auf Anfrage

Bestellbeispiel für:

Typ: PB D 501 ...
Ausführung:
Hartmetallbindung, Länge 28 mm

- Körnungs-DIALETTE
- PB D 501 U K

Halterbeispiele → Seite 3-24



Produktspektrum

MKD-DIALETTEN
CVD-Diamant-DIALETTEN

→ Seite 3-16

→ Seite 3-20

Vorteile im Überblick

- Kein Umfassen, dadurch wartungsfrei
- Gleichbleibende Wirkbreite
- Geringe innere Spannungen und frei von Einschlüssen
- Gleichbleibende Eigenschaften der einzelnen Diamanten
- Kontinuität im Leistungsverhalten

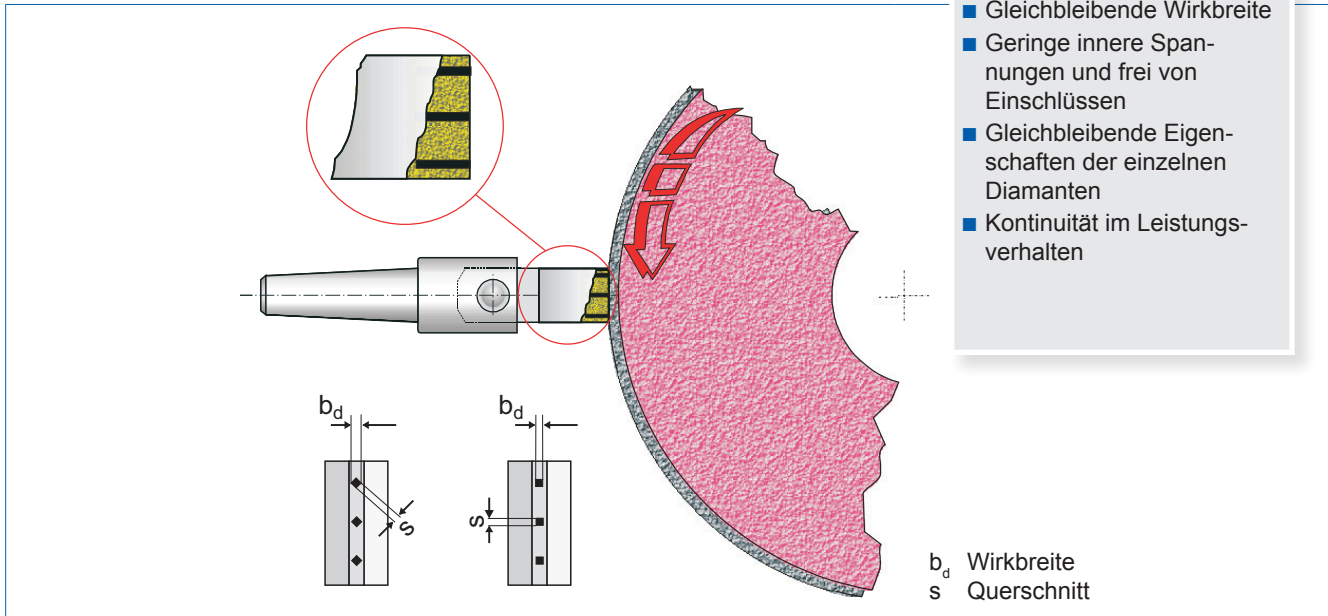

Produktmerkmale

Diese DIALETTEN sind in der Formgebung und im Aufbau ähnlich wie die Nadel- und Körnungs-DIALETTEN. Die MKD- und CVD-Diamant-DIALETTEN sind mit allen Halterformen kompatibel und somit problemlos austauschbar.

Die einseitig bestückten MKD- und CVD-Diamant-DIALETTEN sind auch mit innerer Kühlmittelzufuhr erhältlich. Die hier zum Einsatz gelangenden synthetischen Diamanten sind im Querschnitt quadratisch und behalten diesen Querschnitt auch in ihrer Gesamtlänge bei.

Einsatzbereich

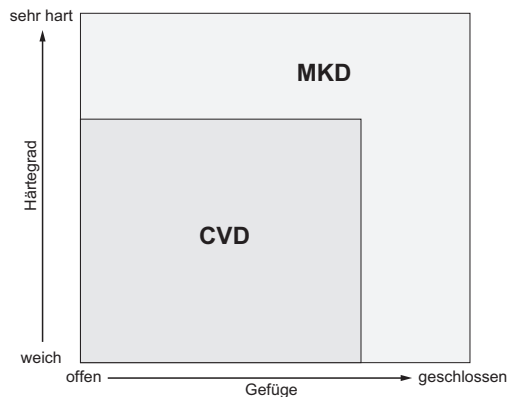

Einsatzbedingungen

- DIALETTE kurz einspannen und fest anziehen.
- Die Achse der DIALETTE sollte genau auf das Zentrum der Schleifscheibe ausgerichtet sein.
- Ausreichende Kühlung erhöht die Lebensdauer der DIALETTEN.

Einsatzparameter

- Abrichtzustellung: 0.02 – 0.03 mm
- Abrichtvorschub: 0.05 – 0.20 mm/U
Abhängig von Scheibekörnung und gewünschter Oberfläche

Mit zunehmender Diagonalstellung der DIALETTE kann:

1. Bei gleichbleibendem Abrichtvorschub eine feinere Oberfläche erzielt werden oder
2. Bei gleichbleibender Oberflächengüte der Abrichtvorschub erhöht werden.



Hinweis: Hat sich die DIALETTE einmal der Schleifscheibe angepasst, sollte die Lage nicht mehr verändert werden.

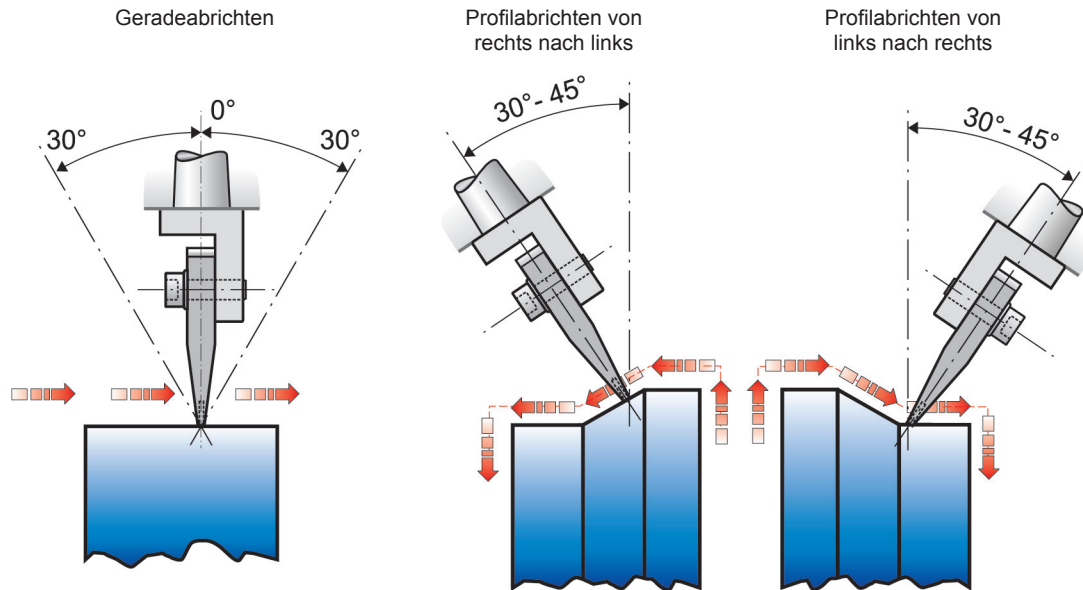

Anwendungsbereiche

- Abrichten von herkömmlichen Korundscheiben, Einsatz hauptsächlich aber in Sinterkorund- und Siliziumkarbid-Schleifscheiben.
- Für kontrollierte Schleifprozesse.
- Zum CNC-Abrichten (wiederholbare Schleifbedingungen).
- Anwendung auf Rund-, Centerless- und Flachsleifmaschinen, beim Einstech-, Pendel- und Profilschleifen.



Die Diamanten können parallel  oder auch unter 45°  eingesetzt werden.

Empfehlung

MKD-Version	
Weiche Scheiben	parallele Version
Harte Scheiben	45°-Version
Radiusabriechen	parallele Version

CVD-Diamant-Version	
Grundsätzlich	45°-Version
Radiusabriechen	parallele Version



DIALETTEN-Abrichter mit MKD

Stehende Abrichtwerkzeuge

DIALETTEN-Abrichter mit MKD

- Erhältlich in vier Bindungsarten
- Zwei Längen lieferbar

Typ HS

	Geeignet für Schleifscheiben			Wirkbreite b_d Version 45° [mm]	Typ
	Durchmesser [mm]	Breite [mm]	Körnung [μ m]		
bis 500	bis 100	ab 280	0.42	HS 03-3 ...	
		150 – 300	0.56	HS 04-3 ...	
		80 – 150	0.85	HS 06-3 ...	
		60 – 80	1.15	HS 08-3 ...	
		46 – 60	1.55	HS 11-3 ...	

Typ HM

	Geeignet für Schleifscheiben			Wirkbreite b_d Version 45° [mm]	Typ
	Durchmesser [mm]	Breite [mm]	Körnung [μ m]		
300 – 800	50 – 250	ab 280	0.42	HM 03-4 ...	
		150 – 300	0.56	HM 04-4 ...	
		80 – 150	0.85	HM 06-4 ...	
		60 – 80	1.15	HM 08-4 ...	
		46 – 60	1.55	HM 11-4 ...	

Typ HB

	Geeignet für Schleifscheiben			Wirkbreite b_d Version 45° [mm]	Typ
	Durchmesser [mm]	Breite [mm]	Körnung [μ m]		
500 – 1500	100 – 600	ab 280	0.42	HB 03-5 ...	
		150 – 300	0.56	HB 04-5 ...	
		80 – 150	0.85	HB 06-5 ...	
		60 – 80	1.15	HB 08-5 ...	
		46 – 60	1.55	HB 11-5 ...	

Bestellinformationen

Verfügbare Ausführungen ¹⁾	Bindungsbezeichnung	Bindungsart	Anwendung / Scheibentyp
Bindung ²⁾	V	Kupferbindung	sehr weiche bis weiche Korundscheiben
	W25	Wolframbindung	weiche bis mittelharte Korundscheiben
	W	Wolframbindung	mittlere bis harte Korundscheiben
	U	Hartmetallbindung	Siliziumkarbidscheiben

	Ausführung K	Ausführung L
Länge l [mm]	28	33

¹⁾ Andere MKD-DIALETTEN auf Anfrage ²⁾ Andere Bindungen auf Anfrage

Bestellbeispiel für:

Typ: HS 11-3 ...
Ausführung:
Kupferbindung, Länge 33 mm

- MKD-DIALETTE
- HS 11-3 V L

Halterbeispiele → Seite 3-24



DIALETTEN-Abriecher mit MKD mit innerer Kühlmittelzufuhr

- Einsatz bei offenem Gefüge oder wo die Kühlung allgemein Probleme bereitet, sei es durch Unzugänglichkeit, fehlende Anschlüsse oder sonstiges.
- Erhältlich in zwei Bindungsarten
- Zwei Längen lieferbar
- Die Lieferung erfolgt mit Anschluss und 0.5-m-Schlauch

Typ HS

	Geeignet für Schleifscheiben			Wirkbreite b_d Version 45° [mm]	Typ
	Durchmesser [mm]	Breite [mm]	Körnung [μ m]		
bis 500	bis 100	ab 280	0.42	HS 03-3 ... T	
		150 – 300	0.56	HS 04-3 ... T	
		80 – 150	0.85	HS 06-3 ... T	
		60 – 80	1.15	HS 08-3 ... T	
		46 – 60	1.55	HS 11-3 ... T	

Typ HM

	Geeignet für Schleifscheiben			Wirkbreite b_d Version 45° [mm]	Typ
	Durchmesser [mm]	Breite [mm]	Körnung [μ m]		
300 – 800	50 – 250	ab 280	0.42	HM 03-4 ... T	
		150 – 300	0.56	HM 04-4 ... T	
		80 – 150	0.85	HM 06-4 ... T	
		60 – 80	1.15	HM 08-4 ... T	
		46 – 60	1.55	HM 11-4 ... T	

Typ HB

	Geeignet für Schleifscheiben			Wirkbreite b_d Version 45° [mm]	Typ
	Durchmesser [mm]	Breite [mm]	Körnung [μ m]		
500 – 1500	100 – 600	ab 280	0.42	HB 03-5 ... T	
		150 – 300	0.56	HB 04-5 ... T	
		80 – 150	0.85	HB 06-5 ... T	
		60 – 80	1.15	HB 08-5 ... T	
		46 – 60	1.55	HB 11-5 ... T	

Bestellinformationen

Verfügbare Ausführungen ¹⁾	Bindungsbezeichnung	Bindungsart	Anwendung / Scheibentyp
	Bindung ²⁾	V	Kupferbindung
	W25	Wolframbindung	weiche bis mittelharte Korundscheiben
	Ausführung K		Ausführung L
Länge l [mm]	28		33

¹⁾ Andere MKD-DIALETTEN auf Anfrage ²⁾ Andere Bindungen auf Anfrage

Bestellbeispiel für:

Typ: HM 08-4 ... T
Ausführung:
Wolframbindung, Länge 28 mm

- MKD-DIALETTE
- HM 08-4 W25 K T

Halterbeispiele → Seite 3-24



Doppel-DIALETTEN-Abrichter mit MKD

Stehende Abrichtwerkzeuge

Doppel-DIALETTEN-Abrichter mit MKD

■ Erhältlich in zwei Bindungsarten

Typ HS

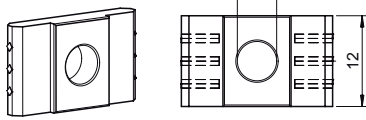
	Geeignet für Schleifscheiben			Wirkbreite b_d Version 45° [mm]	Typ
	Durchmesser [mm]	Breite [mm]	Körnung [μ m]		
	bis 500	bis 100	ab 280	0.42	HS 03-3 2...
			150 – 300	0.56	HS 04-3 2...
			80 – 150	0.85	HS 06-3 2...
			60 – 80	1.15	HS 08-3 2...
			46 – 60	1.55	HS 11-3 2...

Typ HM

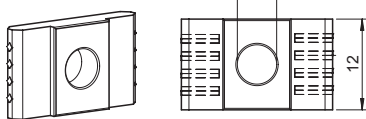
	Geeignet für Schleifscheiben			Wirkbreite b_d Version 45° [mm]	Typ
	Durchmesser [mm]	Breite [mm]	Körnung [μ m]		
	300 – 800	50 – 250	ab 280	0.42	HM 03-4 2...
			150 – 300	0.56	HM 04-4 2...
			80 – 150	0.85	HM 06-4 2...
			60 – 80	1.15	HM 08-4 2...
			46 – 60	1.55	HM 11-4 2...

Typ HB

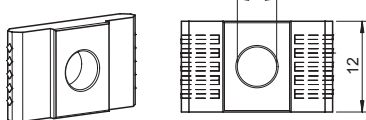
	Geeignet für Schleifscheiben			Wirkbreite b_d Version 45° [mm]	Typ
	Durchmesser [mm]	Breite [mm]	Körnung [μ m]		
	500 – 1500	100 – 600	ab 280	0.42	HB 03-5 2...
			150 – 300	0.56	HB 04-5 2...
			80 – 150	0.85	HB 06-5 2...
			60 – 80	1.15	HB 08-5 2...
			46 – 60	1.55	HB 11-5 2...

Bestellinformationen

Verfügbare Ausführungen ¹⁾	Bindungsbezeichnung	Bindungsart	Anwendung / Scheibentyp
Bindung ²⁾	V	Kupferbindung	sehr weiche bis weiche Korundscheiben
	W25	Wolframbindung	weiche bis mittelharte Korundscheiben

¹⁾ Andere MKD-DIALETTEN auf Anfrage ²⁾ Andere Bindungen auf Anfrage

Bestellbeispiel für:

Typ: HB 06-5 2...
Ausführung: Kupferbindung

- MKD-DIALETTE
- HB 06-5 2V

Halterbeispiele → Seite 3-27



Quattro-DIALETTEN-Abrichter mit MKD

- Erhältlich in zwei Bindungsarten

Typ HS

Durchmesser [mm]	Breite [mm]	Geeignet für Schleifscheiben		Wirkbreite b_d Version 45° [mm]	Typ
		Körnung [μ m]			
bis 500	bis 100	ab 280		0.42	HS 03-3 Q...
		150 – 300		0.56	HS 04-3 Q...
		80 – 150		0.85	HS 06-3 Q...
		60 – 80		1.15	HS 08-3 Q...
		46 – 60		1.55	HS 11-3 Q...

Typ HM

Durchmesser [mm]	Breite [mm]	Geeignet für Schleifscheiben		Wirkbreite b_d Version 45° [mm]	Typ
		Körnung [μ m]			
300 – 800	50 – 250	ab 280		0.42	HM 03-4 Q...
		150 – 300		0.56	HM 04-4 Q...
		80 – 150		0.85	HM 06-4 Q...
		60 – 80		1.15	HM 08-4 Q...
		46 – 60		1.55	HM 11-4 Q...

Typ HB

Durchmesser [mm]	Breite [mm]	Geeignet für Schleifscheiben		Wirkbreite b_d Version 45° [mm]	Typ
		Körnung [μ m]			
500 – 1500	100 – 600	ab 280		0.42	HB 03-5 Q...
		150 – 300		0.56	HB 04-5 Q...
		80 – 150		0.85	HB 06-5 Q...
		60 – 80		1.15	HB 08-5 Q...
		46 – 60		1.55	HB 11-5 Q...

Bestellinformationen

Verfügbare Ausführungen ¹⁾	Bindungsbezeichnung	Bindungsart	Anwendung / Scheibentyp
Bindung ²⁾	V	Kupferbindung	sehr weiche bis weiche Korundscheiben
	W25	Wolframbindung	weiche bis mittelharte Korundscheiben

¹⁾ Andere MKD-DIALETTEN auf Anfrage ²⁾ Andere Bindungen auf Anfrage

Bestellbeispiel für:

Typ: HM 04-4 Q...
Ausführung: Wolframbindung

- MKD-DIALETTE
- HM 04-4 QW25

Halterbeispiele → Seite 3-27



DIALETTEN-Abrichter mit CVD-Diamant

Stehende Abrichtwerkzeuge

DIALETTEN-Abrichter mit CVD-Diamant

- Erhältlich in vier Bindungsarten
- Zwei Längen lieferbar

Typ CS

	Geeignet für Schleifscheiben			Wirkbreite b_d Version 45° [mm]	Typ
	Durchmesser [mm]	Breite [mm]	Körnung [μ m]		
bis 500	bis 100	ab 280	0.42	CS 03-3 ...	
		150 – 300	0.56	CS 04-3 ...	
		80 – 150	0.85	CS 06-3 ...	
		60 – 80	1.15	CS 08-3 ...	
		46 – 60	1.55	CS 11-3 ...	

Typ CM

	Geeignet für Schleifscheiben			Wirkbreite b_d Version 45° [mm]	Typ
	Durchmesser [mm]	Breite [mm]	Körnung [μ m]		
300 – 800	50 – 250	ab 280	0.42	CM 03-4 ...	
		150 – 300	0.56	CM 04-4 ...	
		80 – 150	0.85	CM 06-4 ...	
		60 – 80	1.15	CM 08-4 ...	
		46 – 60	1.55	CM 11-4 ...	

Typ CB

	Geeignet für Schleifscheiben			Wirkbreite b_d Version 45° [mm]	Typ
	Durchmesser [mm]	Breite [mm]	Körnung [μ m]		
500 – 1500	100 – 600	ab 280	0.42	CB 03-5 ...	
		150 – 300	0.56	CB 04-5 ...	
		80 – 150	0.85	CB 06-5 ...	
		60 – 80	1.15	CB 08-5 ...	
		46 – 60	1.55	CB 11-5 ...	

Bestellinformationen

Verfügbare Ausführungen ¹⁾	Bindungsbezeichnung	Bindungsart	Anwendung / Scheibentyp
Bindung ²⁾	V	Kupferbindung	sehr weiche bis weiche Korundscheiben
	W25	Wolframbindung	weiche bis mittelharte Korundscheiben
	W	Wolframbindung	mittlere bis harte Korundscheiben
	U	Hartmetallbindung	Siliziumkarbidscheiben

	Ausführung K	Ausführung L
Länge l [mm]	28	33

¹⁾ Andere CVD-Diamant-DIALETTEN auf Anfrage ²⁾ Andere Bindungen auf Anfrage

Bestellbeispiel für:

Typ: CS 11-3 ...
Ausführung:
Kupferbindung, Länge 33 mm

- CVD-Diamant-DIALETTE
- CS 11-3 V L

Halterbeispiele → Seite 3-24



DIALETTEN-Abrichter mit CVD-Diamant mit innerer Kühlmittelzufuhr

- Einsatz bei porösen Scheiben oder wo die Kühlung allgemein Probleme bereitet, sei es durch Unzugänglichkeit, fehlende Anschlüsse oder sonstiges.
- Erhältlich in zwei Bindungsarten
- Zwei Längen lieferbar
- Die Lieferung erfolgt mit Anschluss und 0.5 m Schlauch

Typ CS

	Geeignet für Schleifscheiben			Wirkbreite b_d Version 45° [mm]	Typ
	Durchmesser [mm]	Breite [mm]	Körnung [μ m]		
bis 500	bis 100	ab 280	0.42	CS 03-3 ... T	
		150 – 300	0.56	CS 04-3 ... T	
		80 – 150	0.85	CS 06-3 ... T	
		60 – 80	1.15	CS 08-3 ... T	
		46 – 60	1.55	CS 11-3 ... T	

Typ CM

	Geeignet für Schleifscheiben			Wirkbreite b_d Version 45° [mm]	Typ
	Durchmesser [mm]	Breite [mm]	Körnung [μ m]		
300 – 800	50 – 250	ab 280	0.42	CM 03-4 ... T	
		150 – 300	0.56	CM 04-4 ... T	
		80 – 150	0.85	CM 06-4 ... T	
		60 – 80	1.15	CM 08-4 ... T	
		46 – 60	1.55	CM 11-4 ... T	

Typ CB

	Geeignet für Schleifscheiben			Wirkbreite b_d Version 45° [mm]	Typ
	Durchmesser [mm]	Breite [mm]	Körnung [μ m]		
500 – 1500	100 – 600	ab 280	0.42	CB 03-5 ... T	
		150 – 300	0.56	CB 04-5 ... T	
		80 – 150	0.85	CB 06-5 ... T	
		60 – 80	1.15	CB 08-5 ... T	
		46 – 60	1.55	CB 11-5 ... T	

Bestellinformationen

Verfügbare Ausführungen ¹⁾	Bindungsbezeichnung	Bindungsart	Anwendung / Scheibentyp
Bindung ²⁾	V	Kupferbindung	sehr weiche bis weiche Korundscheiben
	W25	Wolframbindung	weiche bis mittelharte Korundscheiben
	Ausführung K		Ausführung L
Länge l [mm]	28		33

¹⁾ Andere CVD-Diamant-DIALETTEN auf Anfrage ²⁾ Andere Bindungen auf Anfrage

Bestellbeispiel für:

Typ: CM 08-4 ... T
Ausführung:
Wolframbindung, Länge 28 mm

- CVD-Diamant-DIALETTE
- CM 08-4 W25 K T

Halterbeispiele → Seite 3-24



Doppel-DIALETTEN-Abrichter mit CVD-Diamant

Stehende Abrichtwerkzeuge

Doppel-DIALETTEN-Abrichter mit CVD-Diamant

■ Erhältlich in zwei Bindungsarten

Typ CS

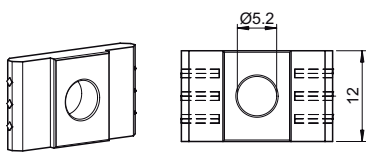
	Geeignet für Schleifscheiben			Wirkbreite b_d Version 45° [mm]	Typ
	Durchmesser [mm]	Breite [mm]	Körnung [μ m]		
	bis 500	bis 100	ab 280	0.42	CS 03-3 2...
			150 – 300	0.56	CS 04-3 2...
			80 – 150	0.85	CS 06-3 2...
			60 – 80	1.15	CS 08-3 2...
			46 – 60	1.55	CS 11-3 2...

Typ CM

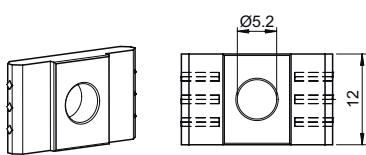
	Geeignet für Schleifscheiben			Wirkbreite b_d Version 45° [mm]	Typ
	Durchmesser [mm]	Breite [mm]	Körnung [μ m]		
	300 – 800	50 – 250	ab 280	0.42	CM 03-4 2...
			150 – 300	0.56	CM 04-4 2...
			80 – 150	0.85	CM 06-4 2...
			60 – 80	1.15	CM 08-4 2...
			46 – 60	1.55	CM 11-4 2...

Typ CB

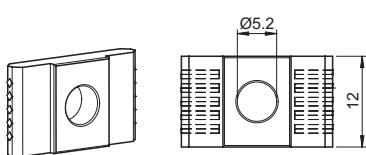
	Geeignet für Schleifscheiben			Wirkbreite b_d Version 45° [mm]	Typ
	Durchmesser [mm]	Breite [mm]	Körnung [μ m]		
	500 – 1500	100 – 600	ab 280	0.42	CB 03-5 2...
			150 – 300	0.56	CB 04-5 2...
			80 – 150	0.85	CB 06-5 2...
			60 – 80	1.15	CB 08-5 2...
			46 – 60	1.55	CB 11-5 2...

Bestellinformationen

Verfügbare Ausführungen ¹⁾	Bindungsbezeichnung	Bindungsart	Anwendung / Scheibentyp
Bindung ²⁾	V	Kupferbindung	sehr weiche bis weiche Korundscheiben
	W25	Wolframbindung	weiche bis mittelharte Korundscheiben

¹⁾ Andere CVD-Diamant-DIALETTEN auf Anfrage ²⁾ Andere Bindungen auf Anfrage

Bestellbeispiel für:

Typ: CB 06-5 2...
Ausführung: Kupferbindung

- CVD-Diamant-DIALETTE
- CB 06-5 2V

Halterbeispiele → Seite 3-27



Quattro-DIALETTEN-Abrichter mit CVD-Diamant

■ Erhältlich in zwei Bindungsarten

Typ CS

Drehansicht	Scheibensicht	Geeignet für Schleifscheiben			Wirkbreite b_d Version 45° [mm]	Typ
		Durchmesser [mm]	Breite [mm]	Körnung [μ m]		
		bis 500	bis 100	ab 280	0.42	CS 03-3 Q...
				150 – 300	0.56	CS 04-3 Q...
				80 – 150	0.85	CS 06-3 Q...
				60 – 80	1.15	CS 08-3 Q...
				46 – 60	1.55	CS 11-3 Q...

Typ CM

Drehansicht	Scheibensicht	Geeignet für Schleifscheiben			Wirkbreite b_d Version 45° [mm]	Typ
		Durchmesser [mm]	Breite [mm]	Körnung [μ m]		
		300 – 800	50 – 250	ab 280	0.42	CM 03-4 Q...
				150 – 300	0.56	CM 04-4 Q...
				80 – 150	0.85	CM 06-4 Q...
				60 – 80	1.15	CM 08-4 Q...
				46 – 60	1.55	CM 11-4 Q...

Typ CB

Drehansicht	Scheibensicht	Geeignet für Schleifscheiben			Wirkbreite b_d Version 45° [mm]	Typ
		Durchmesser [mm]	Breite [mm]	Körnung [μ m]		
		500 – 1500	100 – 600	ab 280	0.42	CB 03-5 Q...
				150 – 300	0.56	CB 04-5 Q...
				80 – 150	0.85	CB 06-5 Q...
				60 – 80	1.15	CB 08-5 Q...
				46 – 60	1.55	CB 11-5 Q...

Bestellinformationen

Verfügbare Ausführungen ¹⁾	Bindungsbezeichnung	Bindungsart	Anwendung / Scheibentyp
	V	Kupferbindung	sehr weiche bis weiche Korundscheiben
	W25	Wolframbindung	weiche bis mittelharte Korundscheiben

¹⁾ Andere CVD-Diamant-DIALETTEN auf Anfrage ²⁾ Andere Bindungen auf Anfrage

Bestellbeispiel für:

Typ: CM 04-4 Q...
Ausführung: Wolframbindung

- CVD-Diamant-DIALETTE
- CM 04-4 QW25

Halterbeispiele → Seite 3-27



Halterbeispiel DIALETTEN schwenkbar auf Klemmhalter

	Typ	Beschreibung	Bestellbeispiel ■ Halter D10 MK1 lang
	Typ	Beschreibung	Bestellbeispiel ■ Halter D11 MK1 kurz
	Typ	Beschreibung	Bestellbeispiel ■ Halter D12 MK0
	Typ	Beschreibung	Bestellbeispiel ■ Halter D13 ■ Zyl. Durchmesser Ød und Länge l nach Angabe



Halterbeispiel DIALETTEN direkt auf Halter gelötet

	<table border="1"> <thead> <tr> <th>Typ</th> <th>Beschreibung</th> </tr> </thead> <tbody> <tr> <td>D14</td> <td>Morse Konus 1, Fortuna</td> </tr> </tbody> </table>	Typ	Beschreibung	D14	Morse Konus 1, Fortuna	<p>Bestellbeispiel für: Nadel-DIALETTE ZB 80 V (D hinter der Typenbezeichnung für „gelötet“)</p> <ul style="list-style-type: none"> ■ Nadel-DIALETTE ZB 80 V D ■ Halter D14 MK1 Fortuna <p>Hinweis: Kann auch mit 0° Neigung bestellt werden. Bitte bei der Bestellung angeben: 0° geneigt</p>
Typ	Beschreibung					
D14	Morse Konus 1, Fortuna					
	<table border="1"> <thead> <tr> <th>Typ</th> <th>Beschreibung</th> </tr> </thead> <tbody> <tr> <td>D15</td> <td>Zylindrischer Halter</td> </tr> </tbody> </table>	Typ	Beschreibung	D15	Zylindrischer Halter	<p>Bestellbeispiel für: Nadel-DIALETTE ZB 80 V (D hinter der Typenbezeichnung für „gelötet“)</p> <ul style="list-style-type: none"> ■ Nadel-DIALETTE ZB 80 V D ■ Halter D15 ■ Zyl. Durchmesser Ød und Länge l nach Angabe
Typ	Beschreibung					
D15	Zylindrischer Halter					
	<table border="1"> <thead> <tr> <th>Typ</th> <th>Beschreibung</th> </tr> </thead> <tbody> <tr> <td>D16</td> <td>Morse Konus 1, kurz</td> </tr> </tbody> </table>	Typ	Beschreibung	D16	Morse Konus 1, kurz	<p>Bestellbeispiel für: Nadel-DIALETTE ZB 60 V (D hinter der Typenbezeichnung für „gelötet“)</p> <ul style="list-style-type: none"> ■ Nadel-DIALETTE ZB 60 V D ■ Halter D16 MK1 kurz
Typ	Beschreibung					
D16	Morse Konus 1, kurz					
	<table border="1"> <thead> <tr> <th>Typ</th> <th>Beschreibung</th> </tr> </thead> <tbody> <tr> <td>D18</td> <td>Morse Konus 1, lang</td> </tr> </tbody> </table>	Typ	Beschreibung	D18	Morse Konus 1, lang	<p>Bestellbeispiel für: Nadel-DIALETTE ZB 60 V (D hinter der Typenbezeichnung für „gelötet“)</p> <ul style="list-style-type: none"> ■ Nadel-DIALETTE ZB 60 V D ■ Halter D18 MK1 lang
Typ	Beschreibung					
D18	Morse Konus 1, lang					
	<table border="1"> <thead> <tr> <th>Typ</th> <th>Beschreibung</th> </tr> </thead> <tbody> <tr> <td>D19</td> <td>Morse Konus 0</td> </tr> </tbody> </table>	Typ	Beschreibung	D19	Morse Konus 0	<p>Bestellbeispiel für: Nadel-DIALETTE ZB 60 V (D hinter der Typenbezeichnung für „gelötet“)</p> <ul style="list-style-type: none"> ■ Nadel-DIALETTE ZB 60 V D ■ Halter D19 MK0
Typ	Beschreibung					
D19	Morse Konus 0					

Fortsetzung siehe nächste Seite



Halterbeispiele für alle DIALETTEN-Abrichter

Direkt auf Halter gelötet

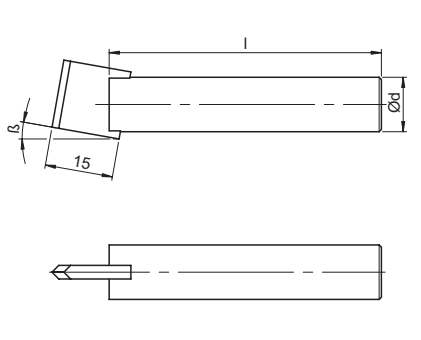
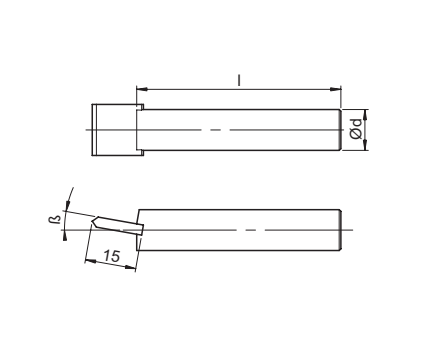
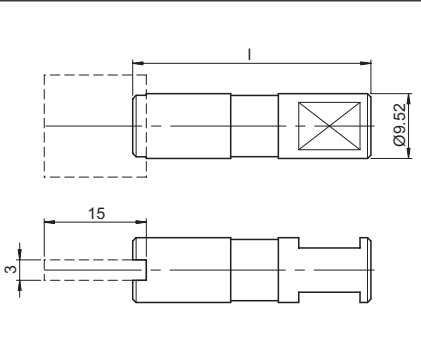
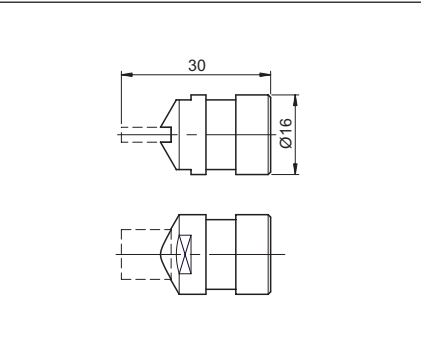
	Typ	Beschreibung	Bestellbeispiel für: Nadel-DIALETTE ZB 60 V (D hinter der Typenbezeichnung für „gelötet“) ■ Nadel-DIALETTE ZB 60 V D ■ Halter D20 ■ Zyl. Durchmesser Ød, Länge l und Winkel β (geneigt) nach Angabe
D20	Zylindrischer Halter, geneigt		
	Typ	Beschreibung	Bestellbeispiel für: Nadel-DIALETTE ZB 60 V (D hinter der Typenbezeichnung für „gelötet“) ■ Nadel-DIALETTE ZB 60 V D ■ Halter D21 ■ Zyl. Durchmesser Ød, Länge l und Winkel β (schräg) nach Angabe
D21	Zylindrischer Halter, schräg		
	Typ	Beschreibung	Bestellbeispiel für: Nadel-DIALETTE ZB 60 V (D hinter der Typenbezeichnung für „gelötet“) ■ Nadel-DIALETTE ZB 60 V D ■ Halter D22 Diaform ■ Länge l nach Angabe
D22	Diaform		
	Typ	Beschreibung	Bestellbeispiel für: Nadel-DIALETTE ZB 60 V (D hinter der Typenbezeichnung für „gelötet“) ■ Nadel-DIALETTE ZB 60 V D ■ Halter D23 Kellenberger Ø16
D23	Kellenberger Ø16		



Halterbeispiele für Doppel- und Quattro-DIALETTEN

	<table border="1"> <thead> <tr> <th>Typ</th> <th>Beschreibung</th> </tr> </thead> <tbody> <tr> <td>D30</td> <td>Morse Konus 1, lang</td> </tr> </tbody> </table>	Typ	Beschreibung	D30	Morse Konus 1, lang		<p>Bestellbeispiel</p> <ul style="list-style-type: none"> ■ Halter D30 MK1 lang
Typ	Beschreibung						
D30	Morse Konus 1, lang						
	<table border="1"> <thead> <tr> <th>Typ</th> <th>Beschreibung</th> </tr> </thead> <tbody> <tr> <td>D31</td> <td>Morse Konus 1, kurz</td> </tr> </tbody> </table>	Typ	Beschreibung	D31	Morse Konus 1, kurz		<p>Bestellbeispiel</p> <ul style="list-style-type: none"> ■ Halter D31 MK1 kurz
Typ	Beschreibung						
D31	Morse Konus 1, kurz						
	<table border="1"> <thead> <tr> <th>Typ</th> <th>Beschreibung</th> </tr> </thead> <tbody> <tr> <td>D32</td> <td>Morse Konus 0</td> </tr> </tbody> </table>	Typ	Beschreibung	D32	Morse Konus 0		<p>Bestellbeispiel</p> <ul style="list-style-type: none"> ■ Halter D32 MK0
Typ	Beschreibung						
D32	Morse Konus 0						
	<table border="1"> <thead> <tr> <th>Typ</th> <th>Beschreibung</th> </tr> </thead> <tbody> <tr> <td>D33</td> <td>Zylindrischer Halter</td> </tr> </tbody> </table>	Typ	Beschreibung	D33	Zylindrischer Halter		<p>Bestellbeispiel</p> <ul style="list-style-type: none"> ■ Halter D33 ■ Zyl. Durchmesser Ød und Länge l nach Angabe
Typ	Beschreibung						
D33	Zylindrischer Halter						
	<table border="1"> <thead> <tr> <th>Typ</th> <th>Beschreibung</th> </tr> </thead> <tbody> <tr> <td>D34</td> <td>Kellenberger Ø16</td> </tr> </tbody> </table>	Typ	Beschreibung	D34	Kellenberger Ø16		<p>Bestellbeispiel</p> <ul style="list-style-type: none"> ■ Halter D34 Kellenberger Ø16
Typ	Beschreibung						
D34	Kellenberger Ø16						



Produktspektrum

Y-Diamantabrichter YA und Halterbeispiele
Diamant-Vielkornabrichter VA und Halterbeispiele
Diamant-Aggregate AGD und Halterbeispiele

→ Seite 3-29

→ Seite 3-30

→ Seite 3-33

Vorteile im Überblick

- Grosse Stabilität und Robustheit
- Kurze Einbaumasse
- Bis zur vollständigen Abnutzung keinerlei Service erforderlich
- Geringe Lagerhaltungskosten
- Zeitersparnis (erhöhter Abrichtvorschub)
- Grosse Abrichtleistung, lange Lebensdauer
- Variierbare Griffigkeit der Schleifscheibe
- Günstiges Verhältnis zwischen Preis und Diamantgewicht



Produktmerkmale

- Diamantgrösse und -gewicht je nach Typ und Anwendungsbereich verschieden.

Y-Diamantabrichter YA

- Handgesetzte Naturdiamant-Nadeln, in verschleissfestem Sintermetall eingebettet.

Diamant-Vielkornabrichter VA / Diamant-Aggregate AGD

- Blockige Natur- oder synthetische Diamant-Körnung, in verschleissfestem Sintermetall eingebettet.

Anwendungsbereiche

- Abrichten von Schleifscheiben in Korund-, Edelmetall- und Siliziumkarbid-Körnung mit keramischer oder Kunstharzbindung.
- Beim Einstech- und Pendelschleifen, AGD auch beim Gewindeschleifen.

Y-Diamantabrichter YA / Diamant-Vielkornabrichter VA / Diamant-Aggregate AGD

- Einsetzbar auf Rund-, Centerless- und Flachsleifmaschinen.
- YA und VA für Scheibendurchmesser 300 – 1500 mm
- AGD für Scheibendurchmesser bis 300 mm und eher feinkörnige Scheiben.

Einsatzbedingungen

- Möglichst kurz einspannen und fest anziehen.
- Die Achse des Abrichtgerätes sollte genau auf das Zentrum der Schleifscheibe ausgerichtet sein.
- Ausreichende Kühlung erhöht die Lebensdauer der Diamanten.
- Abrichtzustellung 0.01 – 0.03 mm
- Abrichtvorschub so weit erhöhen, bis die Scheibe die gewünschte Griffigkeit aufweist.



Y-Diamantabrichter YA

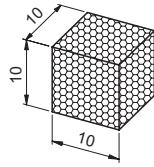

Durchmesser [mm]	Breite [mm]	Geeignet für Schleifscheiben		Diamantgewicht [Karat]	Typ
		Körnung [µm]			
300 – 1200	30 – 60	bis 36		5	YA36
		36 – 54		3	YA46
		54 – 80		2.5	YA60
		80 – 150		2	YA80

Halterbeispiele

■ Weitere Halter → Seite 3-34 oder nach Angabe

Diagramm	Bezeichnung	Typ
	Zylindrischer Halter	Y25
	Morse Konus 1	Y26
	Morse Konus 0	Y27
	Morse Konus 1 geneigt	Y28

Bestellbeispiel

■ YA46, Halter Y26 MK1



Vielkornabrichter und Halterbeispiele Typ VA

Stehende Abrichtwerkzeuge

Diamant-Vielkornabrichter VA

	Diamantgewicht [Karat]	Geeignet für Schleifscheiben			Typ
		Durchmesser [mm]	Breite [mm]	Körnung [µm]	
	1.5	bis 600	bis 200	bis 36	VA9
				36 – 60	VA50
				54 – 100	VA100
	3.5	bis 1000	bis 500	bis 36	VA9
				36 – 60	VA50
				54 – 100	VA100

Halterbeispiele

■ Weitere Halter → Seite 3-34 oder nach Angabe

	Bezeichnung	Ausführung	Abmessungen		Typ
			l1 [mm]	Ød [mm]	
	Zylindrischer Halter	1.5 Karat	–	8	V30
		3.5 Karat	–	10	
	Morse Konus 1	1.5 Karat	13	8	V31
		3.5 Karat	16	10	
	Morse Konus 1, geneigt	1.5 Karat	13	8	V32
		3.5 Karat	16	10	
	Zylindrischer Halter mit Kopf	1.5 Karat	12	8	V33
		3.5 Karat	18	10	
	Morse Konus 1 mit Kopf	1.5 Karat	Halter V31 verwenden		V34
		3.5 Karat	Halter V31 verwenden		

Fortsetzung siehe nächste Seite



	Bezeichnung	Abmessungen			Typ
		Ausführung	l1 [mm]	Ød [mm]	
	Morse Konus 0 mit Kopf	1.5 Karat	15	8	V35
		3.5 Karat	21	10	
	Gewindeschaft M10 x 1	1.5 Karat	–	8	V36
		3.5 Karat	–	10	
	Zylindrischer Halter, geneigt	1.5 Karat	ca. 12	8	V37
		3.5 Karat	ca. 16	10	
	Jung, Kegel 1:10	1.5 Karat	10	8	V38
		3.5 Karat	15	10	
	Morse Konus 0 mit Kopf, geneigt	1.5 Karat	10	8	V39
		3.5 Karat	15	10	
	Morse Konus 1 mit Kopf, geneigt	1.5 Karat	13	8	V40
		3.5 Karat	19	10	



Vielkornabrichter Typ AGD

Stehende Abrichtwerkzeuge

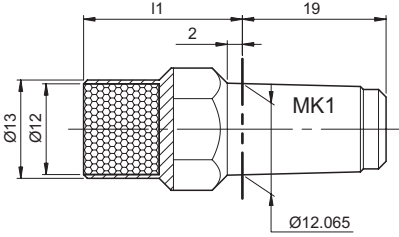
	Bezeichnung	Ausführung	Abmessungen		Typ
			l1 [mm]	Ød [mm]	
	Morse Konus 1 kurz, mit Kopf	1.5 Karat	13	8	V41
		3.5 Karat	19	10	

Bestellbeispiele

- VA50 2.5 Kt, Halter V31 MK1 lang
- VA50 2.5 Kt, Halter V30
- Durchmesser ØD, Länge l und ggf. Winkel α nach Angabe



Diamant-Aggregate AGD

	Grösse	Diamant- gewicht [Karat]	l1 [mm]	Geeignet für	Typ				
				Schleifschei- benkörnung [µm]					
	505	0.5	4.5	36 – 46	AGD852				
				46 – 60	AGD711				
				60	AGD602				
				80	AGD501				
				100	AGD426				
				120	AGD356				
				150	AGD251				
				180	AGD181				
				220	AGD126				
				240 – 280	AGD91				
				320	AGD64				
					615	1.5	9	36 – 46	AGD852
								46 – 60	AGD711
60	AGD602								
80	AGD501								
100	AGD426								
120	AGD356								
150	AGD251								
180	AGD181								
220	AGD126								
240 – 280	AGD91								
320	AGD64								
	820	2.0	8.5					36 – 46	AGD852
								46 – 60	AGD711
				60	AGD602				
				80	AGD501				
				100	AGD426				
				120	AGD356				
				150	AGD251				
				180	AGD181				
				220	AGD126				
				240 – 280	AGD91				
				320	AGD64				

Bestellbeispiel

Andere Diamant-Aggregate nach Angabe
Halterbeispiele → [Seite 3-34](#)



Halterbeispiele

- Weitere Halter → Seite 3-46 oder nach Angabe
- Masse I1 und Ød → Tabelle Seite 3-33

	Bezeichnung	Beschreibung	Typ
	Zylindrischer Halter	<ul style="list-style-type: none"> ■ Ød ist 1 mm kleiner als ØD ■ Masse ØD und l nach Angabe 	G40
	Zylindrischer Halter	<ul style="list-style-type: none"> ■ Ød ist mindestens 2 mm kleiner als ØD ■ Masse ØD und l nach Angabe 	G41
	Zylindrischer Halter mit Kopf	<ul style="list-style-type: none"> ■ Ød ist gleich gross oder grösser als ØD ■ Die Masse ØD, ØD1, l und l2 nach Angabe 	G42
	Morse Konus 0	<ul style="list-style-type: none"> ■ Ød ist maximal 6 mm 	G43
	Morse Konus 1	–	G44
	Morse Konus 1, geneigt	–	G45
	Morse Konus 0, mit Kopf	–	G46
	Morse Konus 0, geneigt	–	G47

Fortsetzung siehe nächste Seite

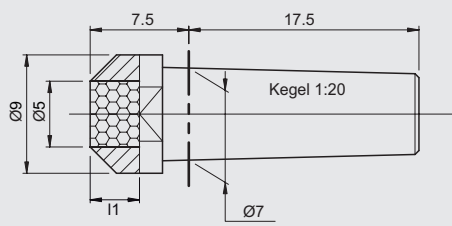
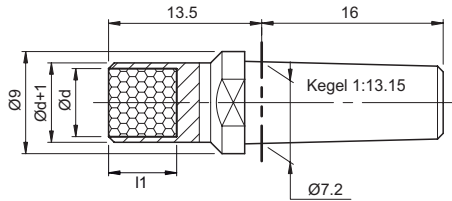
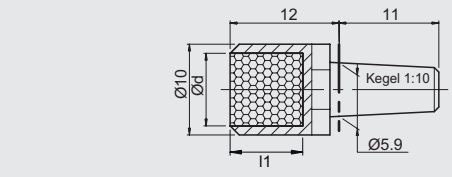
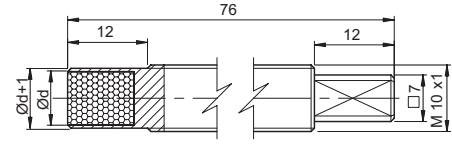

	Bezeichnung	Beschreibung	Typ
	Jung, Kegel 1:20	■ Nur für Aggregat-Grösse 505	G48
	Jung, Kegel 1:13.15	–	G49
	Jung, Kegel 1:10	–	G50
	Gewindeschaft M10 x 1	–	G51

Bestellbeispiel

- AGD501-615. Halter G41
- Durchmesser ØD, Länge l und ggf. Winkel α nach Angabe



Produktspektrum

Diamant-Abrichtleisten

→ Seite 3-37

Vorteile im Überblick

- Einfache Handhabung
- Günstiges Preis-Leistungs-Verhältnis
- Grosser Einsatzbereich

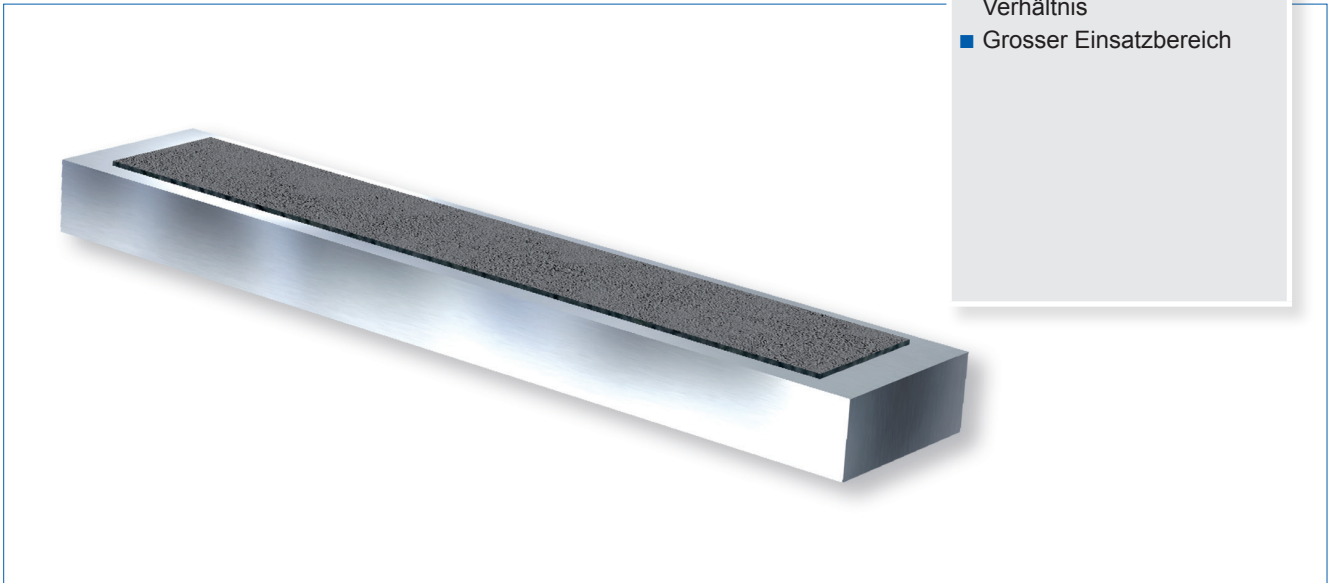

Einsatzempfehlung

- Für das Abrichten/Konditionieren von kunstharz- und keramisch gebundenen CBN- und Diamant-Schleifscheiben.
- Die Abrichtleiste kann auf dem Magnettisch oder Schraubstock gespannt werden.
- Tisch in Längsvorschubrichtung klemmen und mit Quervorschub von ca. 200 mm/min quer über die Leiste fahren.
- Abrichtzustellung je nach CBN-/Diamant-Korngrösse 0.002 mm – 0.010 mm.
- Reichliche Kühlmittelzufuhr erhöht die Standzeit und schont die Schleifscheibe.
- Kunstharzgebundene Schleifscheiben müssen nach dem Abrichtvorgang noch mittels Schärffstein konditioniert werden (Freisetzen der Schleifkörner).

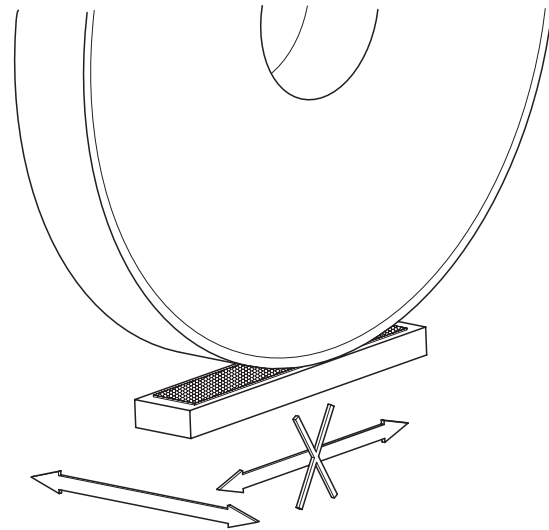



Diamant-Abrichtleisten

- Für das Abrichten/Konditionieren von kunstharz- und keramisch gebundenen CBN- und Diamant-Schleifscheiben.

	Einsatz für Körnung	Körnung ¹⁾ [µm]	Typ
		46 – 91	D126
	76 – 107	D181	04899
	91 – 181	D251	04898
	126 – 251	D356	04897
	181 – 356	D426	16519

Bestellinformationen

Bestellbeispiel für:
Typ 04894

- Diamant-Abrichtleiste
- D251 Typ 04898

¹⁾ Andere Körnungen auf Anfrage



Diamant-Handabrichter

Diamant-Handabrichter HAB

→ Seite 3-39

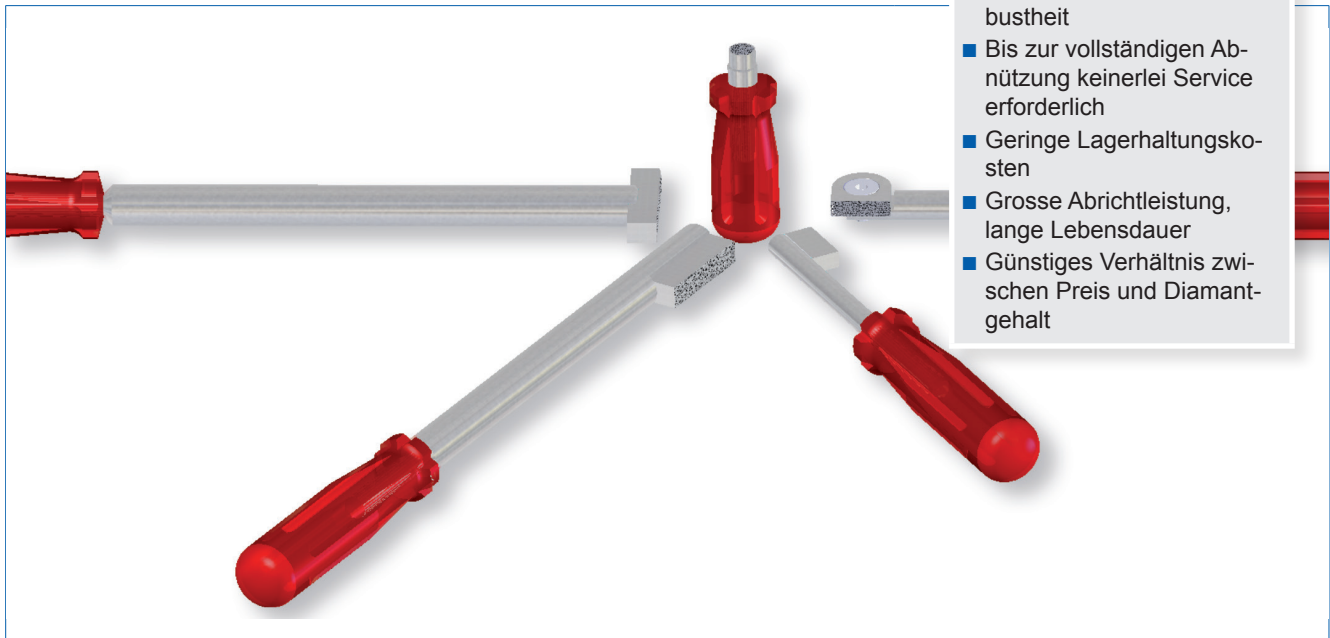

Vorteile im Überblick

- Grosse Stabilität und Robustheit
- Bis zur vollständigen Abnutzung keinerlei Service erforderlich
- Geringe Lagerhaltungskosten
- Grosse Abrichtleistung, lange Lebensdauer
- Günstiges Verhältnis zwischen Preis und Diamantgehalt

Produktmerkmale

- Handgesetzte Naturdiamant-Nadeln oder synthetische Körnungen
- Bei HAB 3 blockige Diamantkörnung
- In verschleissfestem Sintermetall eingebettet
- Diamantgrösse und -gewicht je nach Typ verschieden

Anwendungsbereiche



- Abrichten von Schleifscheiben in Korund-, Edelkorund- und Siliziumkarbid-Körnung mit keramischer Bindung und Kunstharzbindung
- Auf Schleifböcken und Schleifmaschinen ohne Abrichtvorrichtung

Einsatzbedingungen

- Unbedingt Schutzbrille tragen!
- Handabrichter auf die Werkzeugauflage legen und mit leichtem Druck an der Schleifscheibe entlangführen.

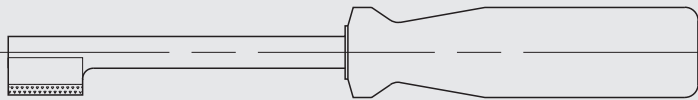
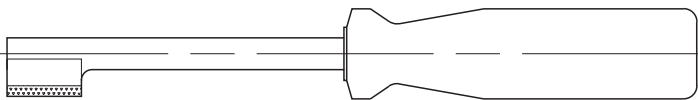
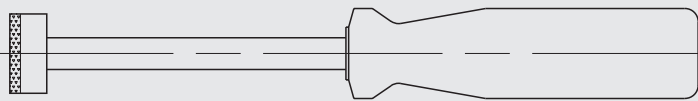
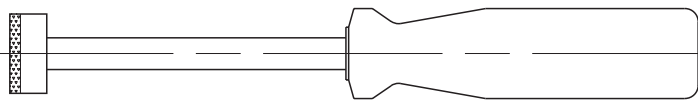
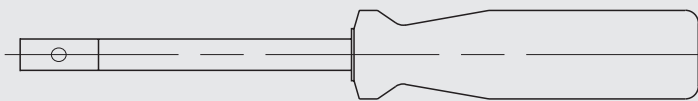

Diamant-Handabrichter HAB

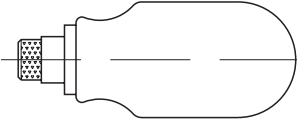
	Beschreibung	Typ
	<ul style="list-style-type: none"> ■ Zum stirnseitigen Abrichten von Schleifscheiben ■ Diamantgehalt: 1.0 Karat + 2 Karat ■ Naturnadeln Handgesetzt 	HAB 1 N
	<ul style="list-style-type: none"> ■ Zum stirnseitigen Abrichten von Schleifscheiben ■ Diamantgehalt: 1.0 Karat + 2 Karat ■ Synthetische Körner gestreut 	HAB 1 K
	<ul style="list-style-type: none"> ■ Zum Abrichten von Schleifscheiben am Umfang ■ Diamantgehalt: 1.0 Karat + 2 Karat ■ Naturnadeln Handgesetzt 	HAB 2 N
	<ul style="list-style-type: none"> ■ Zum Abrichten von Schleifscheiben am Umfang ■ Diamantgehalt: 1.0 Karat + 2 Karat ■ Synthetische Körner gestreut 	HAB 2 K
	<ul style="list-style-type: none"> ■ Durch Schwenkbarkeit der Diamantplatte um 180° zum Abrichten von Schleifscheiben sowohl an der Stirnseite wie am Umfang geeignet 	HAB U (Halter)
	<ul style="list-style-type: none"> ■ Durch Schwenkbarkeit der Diamantplatte um 180° zum Abrichten von Schleifscheiben sowohl an der Stirnseite wie am Umfang geeignet ■ Diamantgehalt: 1.5 Karat ■ Naturnadel Handgesetzt 	HAB U N (Nur Platte)
	<ul style="list-style-type: none"> ■ Durch Schwenkbarkeit der Diamantplatte um 180° zum Abrichten von Schleifscheiben sowohl an der Stirnseite wie am Umfang geeignet ■ Diamantgehalt: 1.5 Karat ■ Synthetische Körner gestreut 	HAB U K (Nur Platte)
	<ul style="list-style-type: none"> ■ Zum Abrichten von Schleifscheiben mit kleinen Abmessungen und/oder feiner Körnung und zum Abrunden von Kanten ■ Diamantgehalt: 1.5 Karat 	HAB 3

Bestellbeispiel

■ HAB 2 N, 2.0 Karat



Produktspektrum

Einkornabrichter mit Naturdiamanten

→ Seite 3-41

Vorteile im Überblick

- Grosser Einsatzbereich
- Grosse Auswahlmöglichkeit
- Stabile Diamantspitze

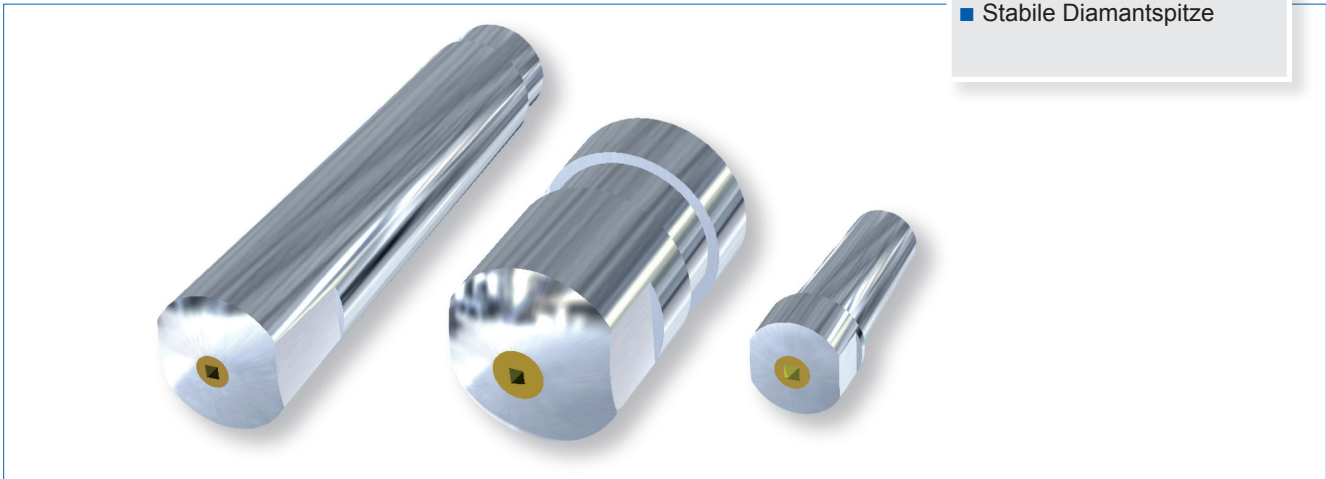

Produktmerkmale

- Unbearbeitete Naturdiamanten unterschiedlicher Grösse und Qualität in Stahlschaft hart eingelötet.
- Diamantgrösse von 0.10 – 2.5 Karat und mehr.
- Die Diamantqualität ist der Sammelbegriff der Faktoren Rissfreiheit, Klarheit, Durchsichtigkeit, Grösse der Einschlüsse und Anzahl der „gesunden“ Spitzen.

Qualitätseinteilung

Qualität	Anzahl „gesunder“ Spitzen
A	5 – 6
1	3 – 4
2	2 – 3
3	1

Anwendungsbereiche

- Abrichten von Schleifscheiben in Korund-, Edelkorund- und Siliziumkarbid-Körnung mit Keramik- oder Kunstharzbindung.
- Auf Rund-, Innen-, Centerless- und Flachsleifmaschinen.
- Beim Einstech-, Pendel- und Profilschleifen.
- Diamantgrösse und der Durchmesser sollen in einem günstigen Verhältnis stehen.

Empfehlung für die Wahl der Diamantgrösse bei Einkorndiamanten

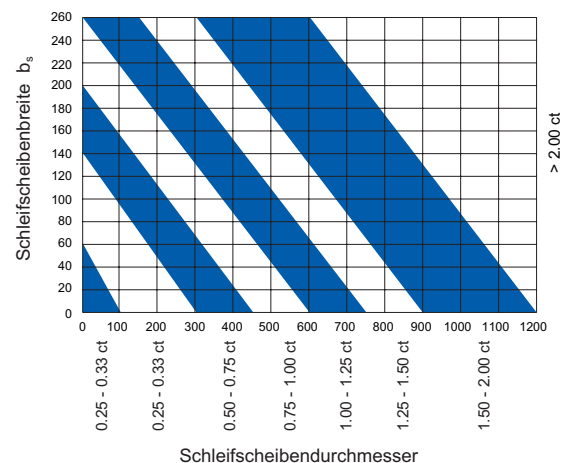

Für das Abrichten von sehr harten und groben Schleifscheiben empfiehlt es sich, ein Abrichtwerkzeug mit der nächsthöheren Stufe einzusetzen.

Einsatzbedingungen

- Abrichtdiamant kurz einspannen und fest anziehen.
- Ausreichende Kühlung erhöht die Lebensdauer des Diamanten.
- Abrichtzustellung 0.01 – 0.03 mm
- Abrichtvorschub 0.03 – 0.05 mm/U
- Abgenützte Fläche am Diamanten nie zu gross werden lassen, Halter immer wieder 90° um seine Achse drehen oder das Werkzeug umfassen lassen.
- Nie in den Halter oder in das Lot schleifen (Ausbruchgefahr für den Diamanten).
- Rechtzeitig umfassen lassen.



Einweg-Abrichtdiamanten

Einweg-Abrichtdiamanten mit einer Diamantgrösse von ca. 0.1 Karat sind eine besonders preisgünstige Variante für Einkorn-Abrichtdiamanten.

Sie werden hauptsächlich bei kleinen Schleifscheiben oder Scheiben mit feiner Körnung eingesetzt.

Allgemeiner Hinweis

Die Preisentwicklung und Verfügbarkeit der letzten Zeit auf dem Diamanten-Weltmarkt hat in besonders starkem Masse die Steingrößen für Einkorn-Abrichtdiamanten betroffen.

Es empfiehlt sich daher, wenn irgend möglich, auf CVD-Diamant-, MKD-Abrichter oder Mehrkorn-Abrichtdiamanten wie DIAROLL, DIALETTEN, YA, VA, AGD oder HAB auszuweichen.

Richtlinien für den Einsatz von Einkorndiamanten

Die Standzeit eines Einkorndiamanten lässt sich wesentlich verlängern, wenn die folgenden Empfehlungen beachtet werden:

1. Die Einspannlänge a (Abstand von der Diamantspitze bis zur Aufnahme) sollte möglichst kurz sein, um einer Zerstörung des Diamanten durch Schwingungen entgegenzuwirken.

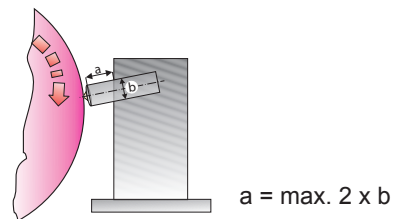

2. Das Diamantwerkzeug sollte in einem Neigungswinkel von 10° bis 15° stehen. Den Diamanten öfter nach Bedarf um 90° drehen, damit immer wieder eine scharfe Kante an der Spitze entsteht.

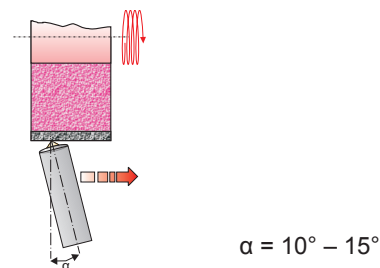

3. Gegebenenfalls kann das Werkzeug auch in der Querachse bis zu 15° geneigt werden.

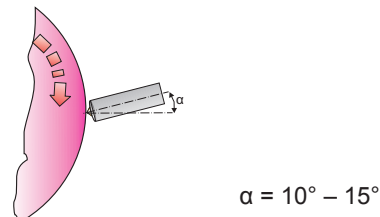

4. Man kann die Spaltebenen und die Kristallwuchsrichtung gezielt ausnützen (siehe nebenstehendes Bild) und so die Lebensdauer eines Einkorndiamanten um 30 % verbessern. Leider wird dies in der Praxis zu wenig beachtet.

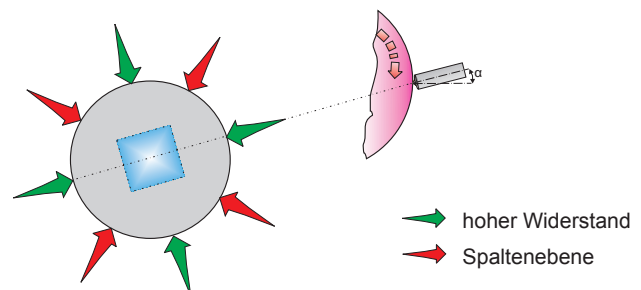



Übersicht Diamantgrößen

Diamantübersicht			
Form	Karat	Qualität	Auswahlhinweis
EA	0.25	A, 1, 2, 3	Produkteigenschaften siehe Seite 3-40
EA	0.35		
EA	0.5		
EA	0.75		
EA	1.0		
EA	1.25		Anwendungshinweis siehe Seite 3-40
EA	1.5		
EA	1.75		
EA	2.00		

Zwischengrößen lieferbar

Einwegdiamant

Diamantübersicht			
Form	Karat	Qualität	Auswahlhinweis
EW	0.1	1	3-41

Bestellbeispiel

- Einkorn-Abrichtdiamant 0.5 Karat
- 2. Qualität
- Schaft Nr. 100 MK1

Halterbeispiele [Seite 3-46](#)





Produktspektrum

MKD-Einkornabrichter

→ Seite 3-45

CVD-Diamant-Einkornabrichter

→ Seite 3-45

Vorteile im Überblick

Vorteile gegenüber Natur-Einkorn-Abrichtdiamanten

- Kein Umfassen, dadurch wartungsfrei
- Gleichbleibende Wirkbreite
- Geringe innere Spannungen und frei von Einschlüssen
- Gleichbleibende Qualität der einzelnen Diamanten d.h. kein Sortieren
- Kontinuität im Leistungsverhalten

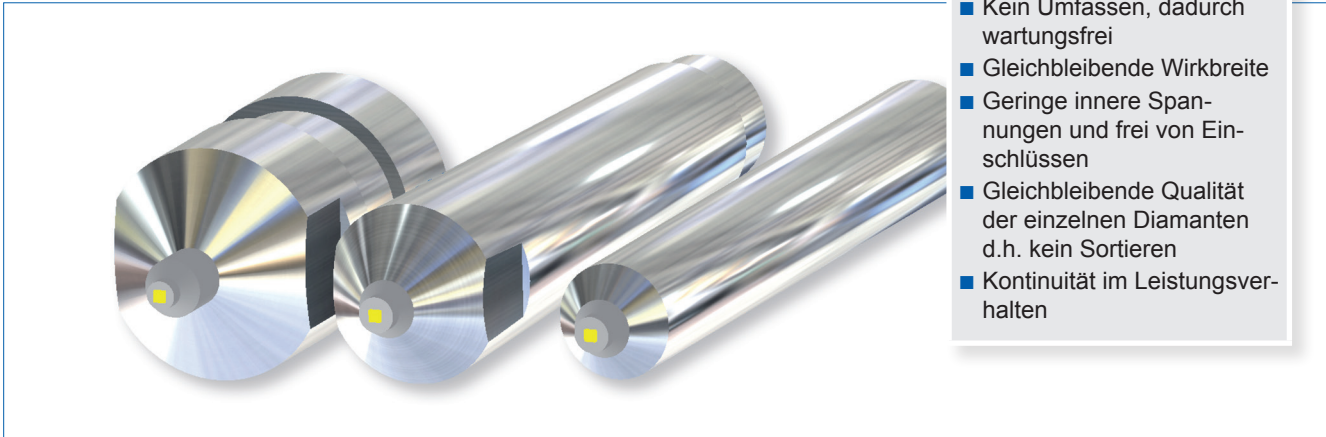

Produktmerkmale

- MKD- und CVD-Diamant wird in Form von Stäbchen mit quadratischem, bei Bedarf auch mit rechteckigem Querschnitt geliefert.
- Die Einkaufsbedingungen von Naturdiamanten auf dem Weltmarkt und die Anforderungen an das Abrichten haben in der letzten Zeit dazu geführt, dass der Bedarf an MKD- und CVD-Diamanten stark gestiegen ist.

Anwendungsbereiche

- Abrichten von herkömmlichen Korundscheiben, Einsatz hauptsächlich aber für Sinterkorund- und Siliziumkarbid-Schleifscheiben.
- Zum CNC-Abrichten (wiederholbare Schleifbedingungen)
- Für kontrollierte Schleifprozesse
- Anwendung auf Rund-, Innen-, Centerless- und Flachschleifmaschinen, beim Einstech-, Pendel- und Profilschleifen

Einsatzbereich

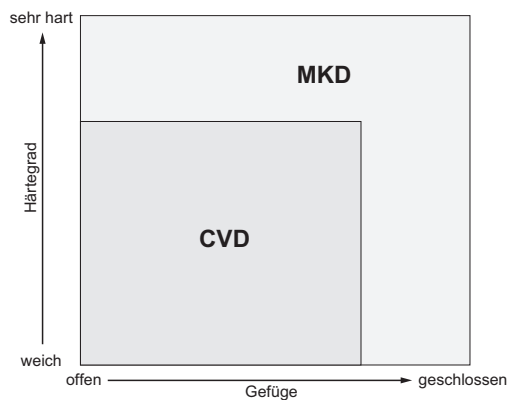

Einsatzbedingungen

- Abrichtdiamant kurz einspannen und fest anziehen
- Ausreichende Kühlung erhöht die Lebensdauer des Diamanten
- Abrichtzustellung 0.01 – 0.03 mm
- Abrichtvorschub 0.05 – 0.2 mm/U



Abrichtdiamant

Typ MKD-Einkornabrichter

Diamant-Querschnitt [mm]	Geeignet für Schleifscheiben-Ø [mm]	Typ
0.4 x 0.4 x 4	100 – 150	MKDA 04-1
0.6 x 0.6 x 4	150 – 300	MKDA 06-1
0.8 x 0.8 x 4	300 – 500	MKDA 08-1
1.1 x 1.1 x 4	500 – 700	MKDA 11-1

Typ CVD-Diamant-Einkornabrichter

Diamant-Querschnitt [mm]	Geeignet für Schleifscheiben-Ø [mm]	Typ
0.4 x 0.4 x 5	100 – 150	CVDA 04-1
0.6 x 0.6 x 5	150 – 300	CVDA 06-1
0.8 x 0.8 x 5	300 – 500	CVDA 08-1
1.1 x 1.1 x 5	500 – 700	CVDA 11-1

Bestellbeispiel

- CVD-Abrichtdiamant CVDA 06-1
- Schaft Nr. 100 MK1

Halterbeispiele → [Seite 3-46](#)



Halterbeispiele für Einkornabrichter

	Bezeichnung	Nr.
	Morse Konus 1 DIN 1820	100
	Morse Konus 1 mit Kopf DIN 1820	101
	Morse Konus 0 DIN 1820	102
	Morse Konus 0 mit Kopf DIN 1820	103
	Konus 1:20 DIN 1820	104
	Deckel	107
	Schaft zylindrisch	108

Fortsetzung siehe nächste Seite, Bestellinformationen → Seite 3-48



	Bezeichnung	Nr.
	Jung, Kegel 1:20	109
	Jung, Kegel 1:13.15 GL = 23 mm	110
	Jung, Kegel 1:13.15 GL = 17 mm	111
	Jung, Kegel 1:10	112
	Jung, Kegel 1:13.15 GL = 20.5 mm	113
	Landis Ød = wahlweise 6 / 6.5 / 8 mm	116
	Niles M8 x 0.75	118
	Niles M10 x 1	119

Fortsetzung und Bestellinformationen siehe nächste Seite



Halterbeispiele für Einkornabrichter

Stehende Abrichtwerkzeuge

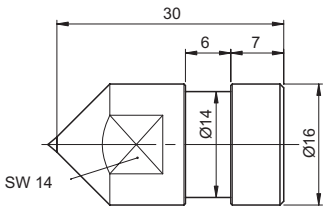
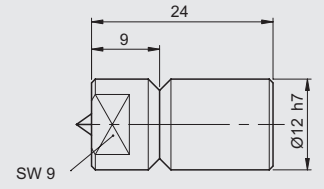
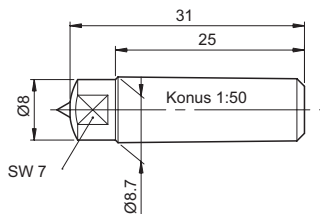
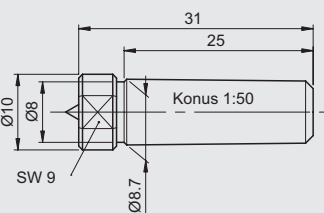
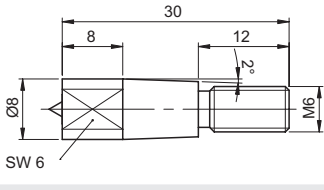
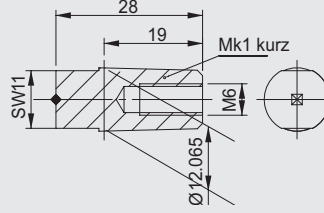
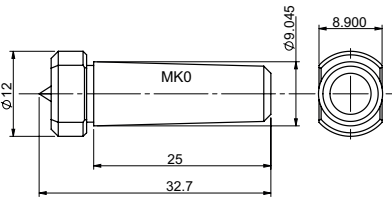
	Bezeichnung	Nr.
	Kellenberger Ø16	120
	Okamoto Ø12 h7	121
	Voumard 1:50	122
	Voumard 1:50 mit Kopf	123
	Agathon	124
	Morse Konus 1 kurz	125
	Voumard MK0	126

Bestellinformationen

Bestellbeispiel

- Halter Nr. 122, Voumard 1:50





Produktspektrum

Dreieckabrichter mit DIAPACT(PKD)
Dreieckabrichter mit CVD-Diamant
Halterbeispiele für Dreieckabrichter

→ Seite 3-51

→ Seite 3-52

→ Seite 3-53

Vorteile im Überblick

- Produktivitätssteigerung durch bessere Oberflächengüte und erhöhte Masshaltigkeit an den Werkstücken
- Reduzierung der Abrichtvorgänge durch verbesserte Standzeit der Schleifscheibe

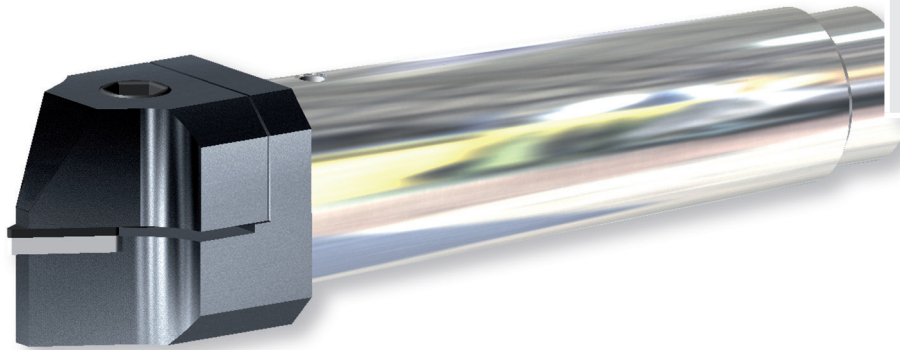

Produktmerkmale

Durch die Dreieckform kann der Abrichter mehrmals verwendet werden, ohne dass er ersetzt oder umgearbeitet werden muss.

DIAPACT (PKD)-Abrichter

- Abrichter mit grobkörniger, polykristalliner Diamantschicht mit Kobalt-Binder.

CVD-Diamantabrichter

- Abrichter mit grobkörniger Diamantschicht ohne Binder.

Anwendungsbereiche

Grundsätzlich genügen die DIAPACT (PKD)-Abrichter für die meisten Abrichtprozesse, bei erhöhtem Verschleiss empfehlen wir die CVD-Diamantabrichter.

- Schleifscheiben: Aluminiumoxid und je nach Härte und Struktur Siliziumkarbid.
- Auf Innen-, Rund- und Flachsleifmaschinen
- Bis Scheibenhärte O
- Körnung 46 – 220 µm

Einsatzbedingungen

- Anstellwinkel des Abrichters ist 0°
- Ausreichende Kühlung erhöht die Lebensdauer des Abrichters.
- Abrichtzustellung bis 0.50 mm möglich.
- Der Vorschub richtet sich nach der Breite der Schneidkante, ist aber grösser als bei Einkorn-Diamanten.



Dreieckabrichter mit DIAPACT(PKD)

- Grundsätzlich genügt die Version TE. Als Ausnahme bei sehr feinen Körnungen lohnt es sich, auf die geschliffene TG-Version auszuweichen.
- Halterbeispiele → [Seite 3-53](#)

Typ TE – erodierte Version

	R [mm]	Typ
	0	TE 000
	0.125	TE 125
	0.2	TE 200
	0.25	TE 250
0.5	TE 500	

Typ TG – geschliffene Version

	R [mm]	Typ
	0	TG 000
	0.125	TG 125
	0.2	TG 200
	0.25	TG 250
0.5	TG 500	

Bestellinformationen

Bestellbeispiel für:

Typ: TE 125

- DIAPACT(PKD)-Abrichter Typ TE 125
- Halter zylindrisch Nr. 208

Weitere Halter oder Radien nach Angabe



Dreieckabrichter mit CVD-Diamanten

Stehende Abrichtwerkzeuge

Dreieckabrichter mit CVD-Diamanten

- Hinweis: bei der CVD-Diamant-Ausführung gibt es nur die Version TL (geschliffen)
- Halterbeispiele → [Seite 3-53](#)

Typ TL – geschliffene Version

	R [mm]	Typ
	0	TL 000
	0.1	TL 100
	0.125	TL 125
	0.2	TL 200
	0.25	TL 250
0.5	TL 500	

Typ TC – CVD-Schicht 0.8mm, geschliffene Version

Hinweis: Anwendung speziell bei abrasiven Schleifscheiben (SIC, Cubitron 2 etc) oder bei hohem Abtrag

	R [mm]	Typ
	0	TC 000
	0.1	TC 100
	0.125	TC 125
	0.2	TC 200
	0.25	TC 250
0.5	TC 500	

Bestellinformationen

Bestellbeispiel für:

Typ: TL 125

- CVD-Diamantabrichter Typ TL 125
- Halter zylindrisch Nr. 210

Weitere Halter oder Radien nach Angabe



Halterbeispiele für Dreieckabrichter

Klemmhalter zylindrisch

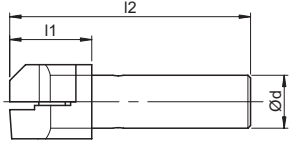
	Ød [mm]	l1 [mm]	l2 [mm]	Nr.
	8	15.5	45.5	208
	10	15.5	45.5	210
	12	15.5	45.5	212

Klemmhalter Morse Konus

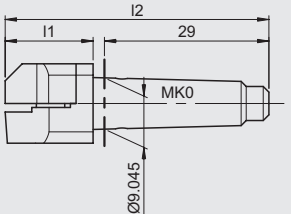
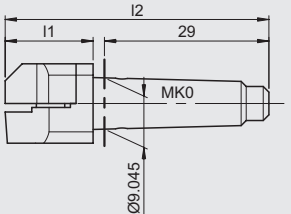
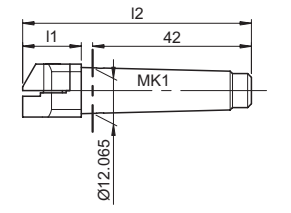
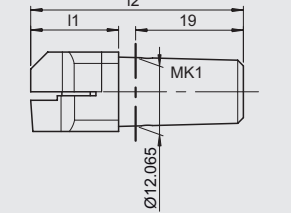
	Bezeichnung	l1 [mm]	l2 [mm]	Nr.
	Morse Konus 0	15.5	46.5	201
	Morse Konus 1, lang	15.5	60.5	203
	Morse Konus 1, kurz	15.5	37.5	204

Bestellinformationen

Bestellbeispiel für:
Klemmhalter Nr. 203

- Klemmhalter
- Morse Konus 1 lang Nr. 203 für Dreieckabrichter

Weitere Halter nach Angabe



Aufnahme Kellenberger Schleifmaschinen

Spezialaufnahmen Schleifmaschinen

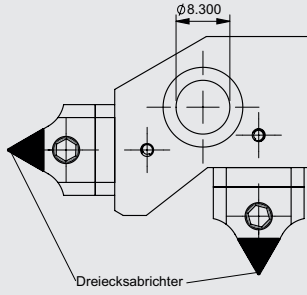
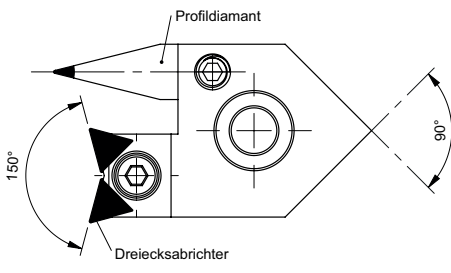
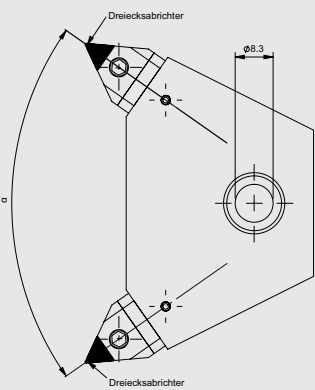
	Maschine	Winkel α	Bestellnummer
	Kellenberger		26357
	Kellenberger		26264
	Kellenberger	70°	27521

Bestellinformationen

Bestellbeispiel für:
Aufnahme 26264

- Aufnahme 26264
- 2 Dreiecksabrichter Typ z.B TE125 (Siehe ab Seite 3-51)
- Profilabrichter Z.B. 40° R0.250 mit Schaft Ø6x10 (Siehe ab Seite 3-61)

Weitere Halter nach Angabe





Produktspektrum

Halterbeispiele für Profilabrichter
Profilabrichter mit neuen MKD-Diamanten

→ Seite 3-57

→ Seite 3-58

Vorteile im Überblick

- stabile Seitenabstützung in der Fassung
- mehrfach Nachschleifbar
- Enge Spitzenwinkel bis zu 25° herstellbar
- Gleichbleibende Qualität
- sehr gutes Preis/Leistungsverhältnis

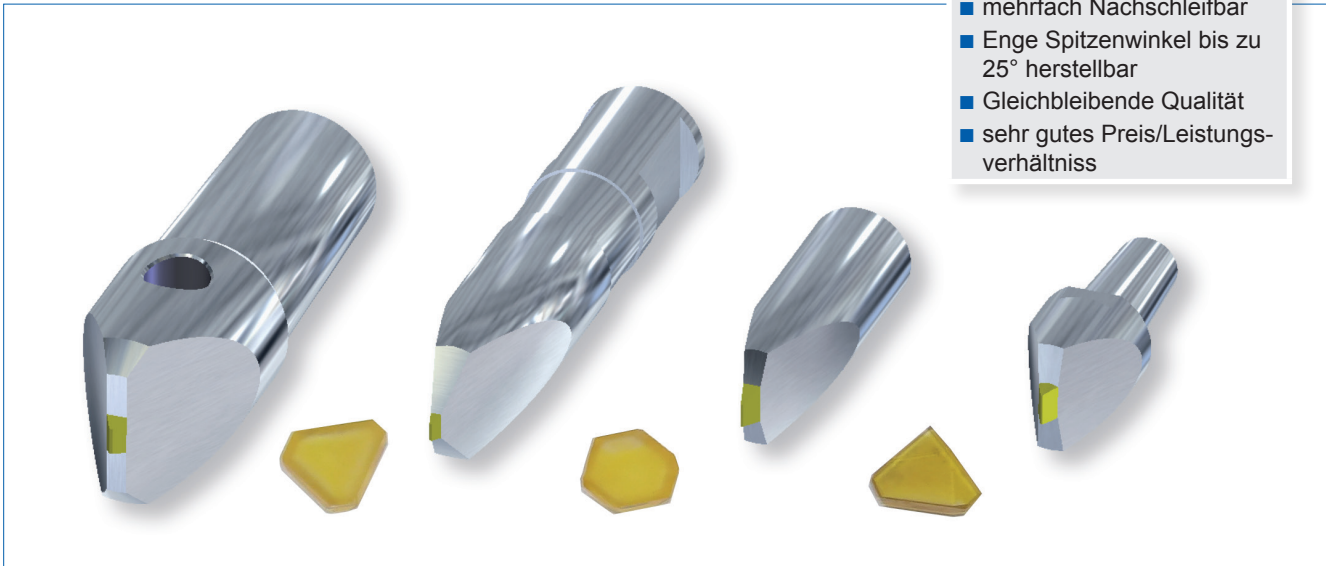

Produktmerkmale

- Formgeschliffener synthetischer Diamant in Stahlschaft eingesintert.
- Bestes Preis/Leistungsverhältnis
- Durch schlanke Bauweise geeignet für Winkel ab 25°
- Hohe Verfügbarkeit
- geringe Preisschwankungen

Anwendungsbereiche

- Profilabrichten von Schleifscheiben in Korund-, Edelkorund- und Siliziumkarbid-Körnung mit keramischer und Kunstharzbindung.
- Auf Rund- und Flachsleifmaschinen
- Beim Profil- und Einstechschleifen

Einsatzbedingungen

- Profildiamanten kurz einspannen und fest anziehen.
- Ausreichende Kühlung erhöht die Lebensdauer des Diamanten.
- Abrichtvorschub 0.02 – 0.15 mm/U
- Nie in den Halter oder das Sintermetall schleifen.
- Rechtzeitig nachschleifen lassen.

Hinweis

Da die Verfügbarkeit von Naturdiamanten mit guter Qualität stark abgenommen hat, empfehlen wir den Umstieg auf MKD-Profildiamanten

Vergleichsgrösse mit Naturdiamant unter Angabe der möglichen Winkel und Radien

MKD-Artikel	mögliche Winkel	mögliche Radien	vergleich Naturdiamant
T35	ab 25°	0.000 bis 0.500	0.35 Karat
T50	ab 30°	0.000 bis 0.500	0.50 Karat
T75	ab 25°	0.000 bis 0.400	0.75 Karat
T100	ab 30°	0.000 bis 0.700	1.00 Karat



Halter für Profilabrichter

PD 40

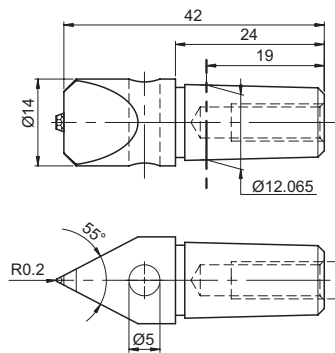

Maschine/System	Typ	α	R [mm]
Fortuna	PD 40	55°	0.200

PD 41

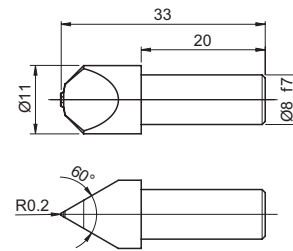

Maschine/System	Typ	α	R [mm]
MSO	PD 41	60°	0.200

PD 42

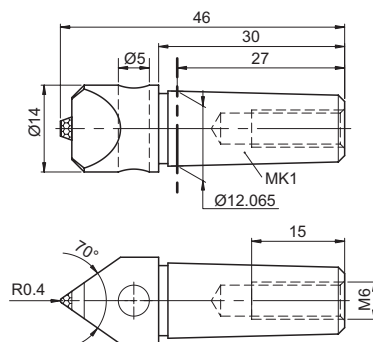

Maschine/System	Typ	α	R [mm]
Schaudt	PD 42	70°	0.400

PD 43

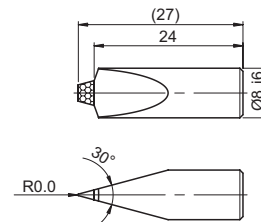

Maschine/System	Typ	α	R [mm]
Aba	PD 43	30°	0.000

PD 45

l [mm]	Typ
35	S
45.5	L
57.8	X

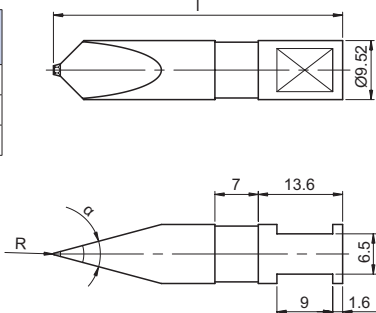

Maschine/System	Typ	α (nach Angabe)	R [mm]
Diaform	PD 45	30° – 60°	0.000 – 0.500

PD 47

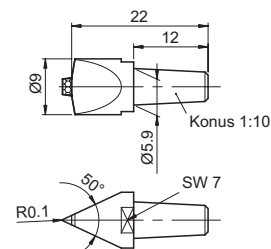

Maschine/System	Typ	α	R [mm]
Jung RA 38-53	PD 47	50°	0.100

Auswahl Profildiamant

MKD-Profildiamant

→ Seite 3-58



1 Neue Profilabrichter mit MKD-Diamant

■ Andere MKD-Profildiamanten wie in folgender Tabelle angegeben auf Anfrage

Typ	Halter (Details → Seite 3-57)			Diamant
	Maschine/ System	α	R [mm]	Bezeichnung
PD 40	Fortuna	55°	0.200	MKD-T100 PD 40 Fortuna 55/200
PD 41	MSO	60°	0.200	MKD-T35 PD 41 MSO 60/200
PD 42	Schaudt	70°	0.400	MKD-T100 PD 42 Schaudt 70/400
PD 43	Aba	30°	0.000	MKD-T35 PD 43 Aba 30/000
PD 45 (Typ S, L und X)	Diaform	30° – 60°	0.000 – 0.500	MKD-T35 PD 45 Diaform MKD-T50 PD 45 Diaform MKD-T75 PD 45 Diaform MKD-T100 PD 45 Diaform Winkel, Radius und Länge nach Wahl
PD 47	Jung, RA 38-53	50°	0.100	MKD-T35 PD 47 Jung RA 38-53 50/100

2 Bestellbeispiel

■ MKD-T135 PD 45 Diaform 40/250 Typ L



Aufnahme Kellenberger Schleifmaschine

Spezialaufnahmen Schleifmaschinen

	Maschine	Bestellnummer
	Kellenberger	26264

Bestellinformationen

Bestellbeispiel für:

Aufnahme 26264

- Aufnahme 26264
- 2 Dreiecksabrichter Typ z.B TE125 (Siehe ab [Seite 3-57](#))
- Profildiamant Z.B. 40° R0.250 mit Schaft Ø6x10

Weitere Halter nach Angabe



Produktspektrum

Halterbeispiele für Profilabrichter
Profilabrichter mit Naturdiamant
Profilabrichter mit MKD-Diamant
Profilabrichter mit CVD-Diamant

→ Seite 3-61

→ Seite 3-62

→ Seite 3-63

→ Seite 3-64

Vorteile im Überblick

- Kostengünstige Alternative zu Abrichtrollen
- Grosser Einsatzbereich
- Nachschleifbar

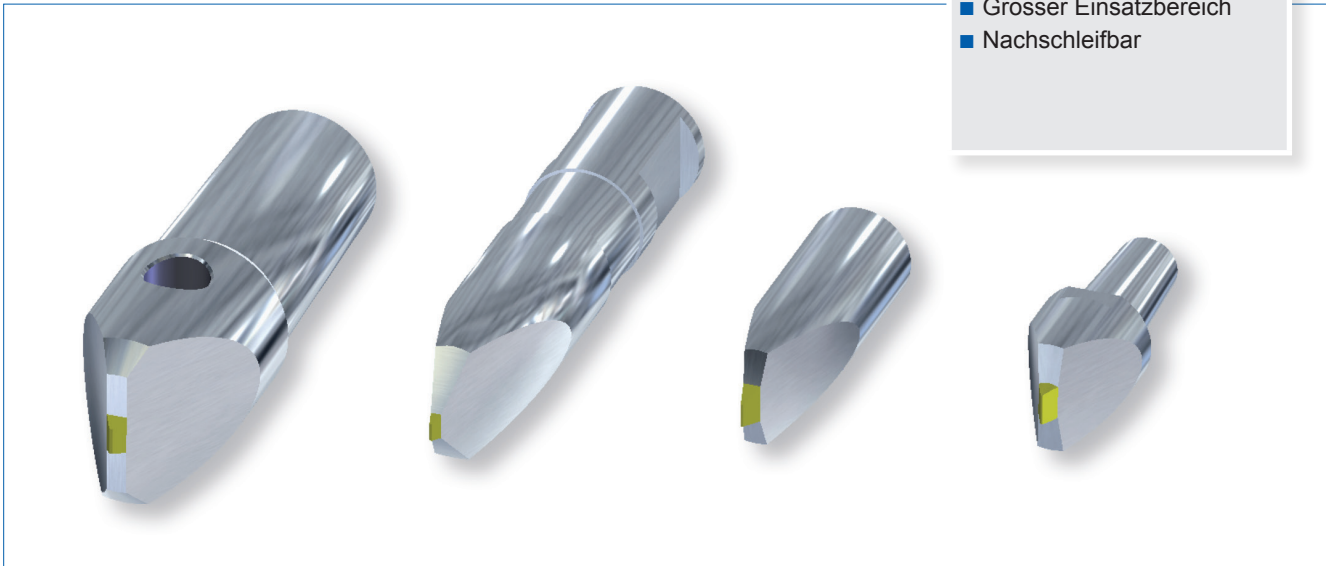

Produktmerkmale

- Formgeschliffene Natur- oder synthetische Diamanten in Stahlschaft eingesintert.
- Diamantgrösse von 0.20 – 2.00 Karat und mehr.
- MKD- und CVD-Diamant in Querschnitt 1.1 mm (Typ 11-1), Giebellänge ca. 1.5 mm oder 1.4 mm (Typ 14-1), Giebellänge ca. 2 mm. Andere Querschnitte auf Anfrage.

Sporndiamanten oder Rougher

- Schlanke, ungeschliffene Naturdiamanten-Nahtdreiecke werden auch zum Vorprofilieren eingesetzt. Die Halterabmessungen sind dieselben.

Anwendungsbereiche

- Profilabrichten von Schleifscheiben in Korund-, Edelkorund- und Siliziumkarbid-Körnung mit keramischer und Kunstharzbindung.
- Auf Rund- und Flachsleifmaschinen
- Beim Profil- und Einsteichschleifen

Einsatzbedingungen

- Profildiamanten kurz einspannen und fest anziehen.
- Ausreichende Kühlung erhöht die Lebensdauer des Diamanten.
- Abrichtvorschub 0.02 – 0.15 mm/U
- Nie in den Halter oder das Sintermetall schleifen.
- Rechtzeitig nachschleifen lassen.

Hinweis

Die Preisentwicklung der letzten Zeit auf dem Diamantweltmarkt hat in besonders starkem Masse die Steingrößen für Einkorn-Abrichtdiamanten, zu denen Profildiamanten gehören, betroffen.

Es empfiehlt sich daher, wenn irgend möglich, auf MKD- oder CVD-Diamantabrichter oder Mehrkorn-Diamantabrichter wie DIAROLL oder DIALETTEN auszuweichen.



Halter für Profilabrichter

PD 40

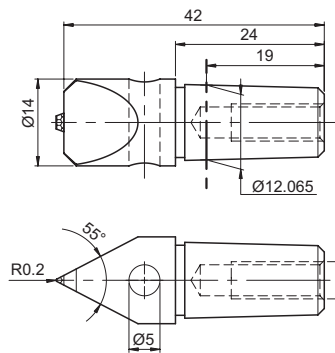

Maschine/System	Typ	α	R [mm]
Fortuna	PD 40	55°	0.200

PD 41

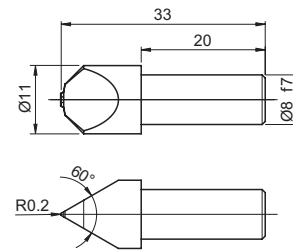

Maschine/System	Typ	α	R [mm]
MSO	PD 41	60°	0.200

PD 42

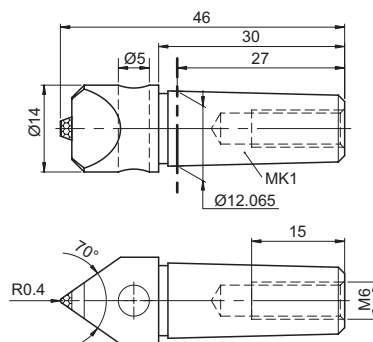

Maschine/System	Typ	α	R [mm]
Schaudt	PD 42	70°	0.400

PD 43

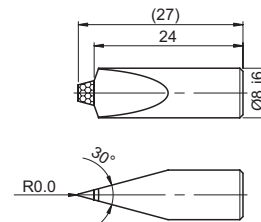

Maschine/System	Typ	α	R [mm]
Aba	PD 43	30°	0.000

PD 45

l [mm]	Typ
35	S
45.5	L
57.8	X

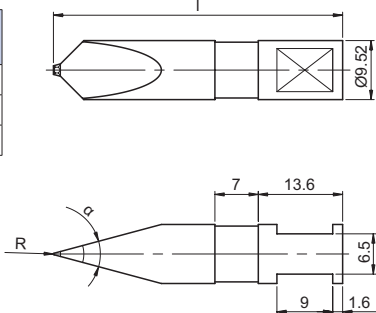

Maschine/System	Typ	α	R [mm]
Diaform	PD 45	(nach Angabe)	0.000 – 0.500

PD 47

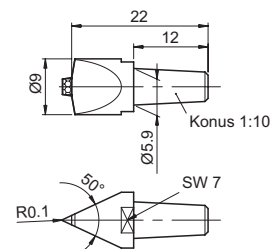

Maschine/System	Typ	α	R [mm]
Jung RA 38-53	PD 47	50°	0.100

Auswahl Profildiamant

- Natur-Profildiamant → Seite 3-62
- MKD-Profildiamant → Seite 3-63
- CVD-Profildiamant → Seite 3-64



Profilabrichter mit Naturdiamant

■ Andere Natur-Profildiamanten wie in folgender Tabelle angegeben auf Anfrage

Halter (Details → Seite 3-61)				
Typ	Maschine/System	α	R [mm]	Empfohlene Diamantgrößen [Karat]
PD 40	Fortuna	55°	0.200	1.00 1.50 2.00
PD 41	MSO	60°	0.200	0.25 0.35 0.50 0.75 1.00 1.50 2.00
PD 42	Schautd	70°	0.400	1.00 1.50 2.00
PD 43	Aba	30°	0.000	0.35 0.50 0.75
PD 45 (Typ S, L und X)	Diaform	30° – 60°	0.000 – 0.500	0.25 0.35 0.50 0.75
PD 47	Jung, RA 38-53	50°	0.100	0.25 0.35 0.50 0.75

Bestellbeispiel

■ Natur-Profildiamant PD 47 Jung, RA 38-53 50/100, 0.35 Karat



Profilabrichter mit MKD-Diamant

- Andere MKD-Profildiamanten wie in folgender Tabelle angegeben auf Anfrage

Typ	Halter (Details → Seite 3-61)			Diamant	
	Maschine/ System	α	R [mm]	Giebellänge [mm]	Bezeichnung
PD 40	Fortuna	55°	0.200	1.5 2.0	MKDP 11-1 MKDP 14-1
PD 41	MSO	60°	0.200	1.5 2.0	MKDP 11-1 MKDP 14-1
PD 42	Schaudt	70°	0.400	1.5 2.0	MKDP 11-1 MKDP 14-1
PD 43	Aba	30°	0.000	1.5 2.0	MKDP 11-1 MKDP 14-1
PD 45 (Typ S, L und X)	Diaform	30° – 60°	0.000 – 0.500	1.5 2.0	MKDP 11-1 MKDP 14-1
PD 47	Jung, RA 38-53	50°	0.100	1.5 2.0	MKDP 11-1 MKDP 14-1

Bestellbeispiel

- MKD-Profildiamant PD 40 Fortuna 55/200, MKDP 14-1



Profilabrichter mit CVD-Diamant

- Andere CVD-Profildiamanten wie in folgender Tabelle angegeben auf Anfrage

Typ	Halter (Details → Seite 3-61)			Diamant	
	Maschine/ System	α	R [mm]	Giebellänge [mm]	Bezeichnung
PD 40	Fortuna	55°	0.200	1.5 2.1	CVDP 11-1 CVDP 15-1
PD 41	MSO	60°	0.200	1.5 2.1	CVDP 11-1 CVDP 15-1
PD 42	Schaudt	70°	0.400	1.5 2.1	CVDP 11-1 CVDP 15-1
PD 43	Aba	30°	0.000	1.5 2.1	CVDP 11-1 CVDP 15-1
PD 45 (Typ S, L und X)	Diaform	30° – 60°	0.000 – 0.500	1.5 2.1	CVDP 11-1 CVDP 15-1
PD 47	Jung RA 38-53	50°	0.100	1.5 2.1	CVDP 11-1 CVDP 15-1

Bestellbeispiel

- CVD-Profildiamant PD 45 Diaform 40/250, CVDP 11-1 Typ L



Aufnahme Kellenberger Schleifmaschine

Spezialaufnahmen Schleifmaschinen

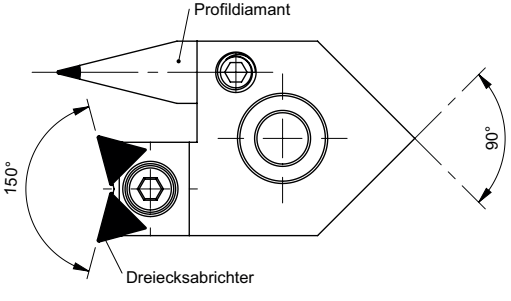
	Maschine	Bestellnummer
	Kellenberger	26264

Bestellinformationen

Bestellbeispiel für:

Aufnahme 26264

- Aufnahme 26264
- 2 Dreiecksabrichter Typ z.B TE125 (Siehe ab [Seite 3-51](#))
- Profildiamant Z.B. 40° R0.250 mit Schaft Ø6x10

Weitere Halter nach Angabe



Produktspektrum

DRESSER-Abrichtgeräte

→ Seite 3-67

DRESSER-Abrichteinheiten

→ Seite 3-67

Zubehör und Ersatzteile

→ Seite 3-69

Vorteile im Überblick

- Schalldämpfer aus Metall
- Stoppvorrichtung für rationelles und handliches Wechseln der Abrichtscheiben
- Einsatz auf Flach- und Rundschleifmaschinen
- Kompatibel für alle Abrichtscheiben
- Kurze Rüstzeit
- Platzsparend

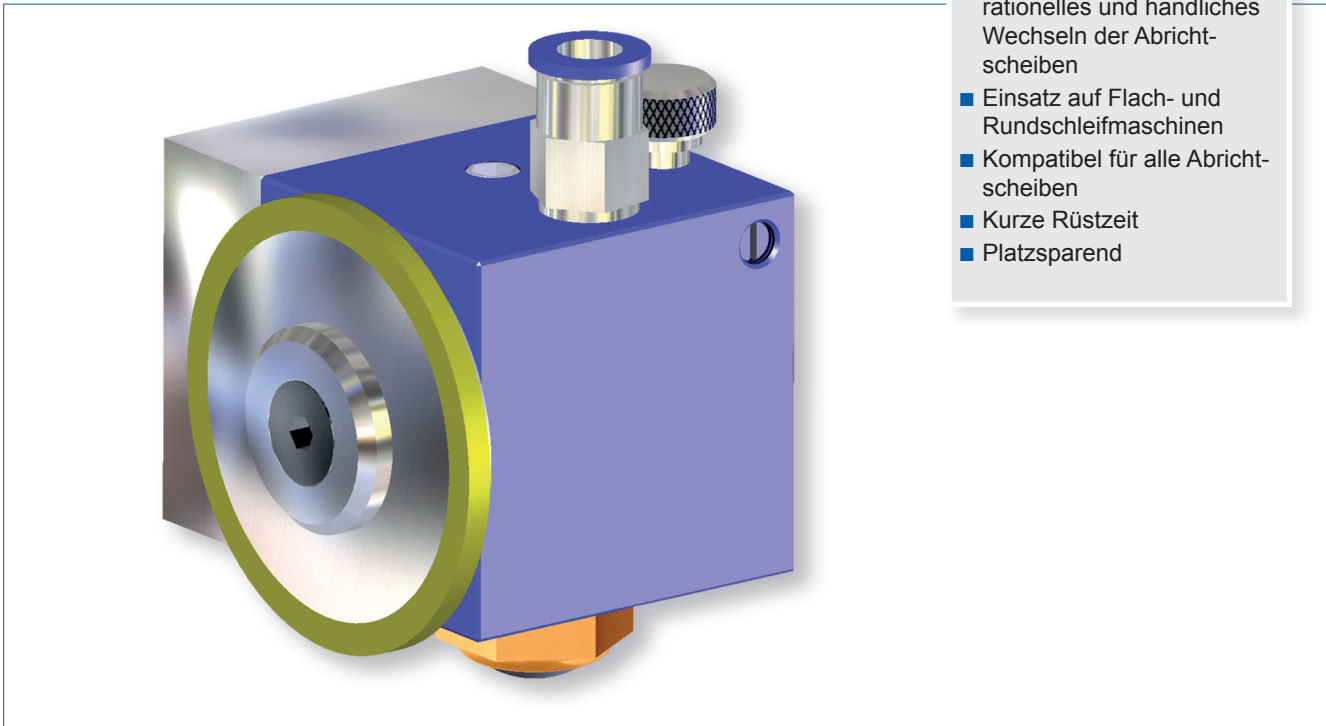

Produktmerkmale

Einsatzgebiet

- Abrichten von CBN- und Diamant-Schleifscheiben mit Bindungen aus Kunstharz und Keramik sowie allen Korund- und Siliziumkarbidscheiben im Durchmesserbereich von 10 mm – 400 mm.
- Nachrüstung auf bestehende Rund-, Innenrund-, Flach- und Werkzeugschleifmaschinen.

Kühlung

- Diamant als härtester Rohstoff ist sehr wärmeempfindlich. Wie bei allen Abrichtwerkzeugen sollte auch der WEISS DRESSER nur unter Zuführung von reichlich Kühlmittel eingesetzt werden. Bei Unterlassung reduziert sich die Lebensdauer des Diamant-Abrichtrades erheblich.

Zubehör

- Umfangreiches Zubehör → Seite 3-69
- Aufspannvorrichtungen für diverse Maschinentypen auf Anfrage.

Richtwerte

- Abrichtzustellung/Überlauf 0.002 – 0.005 mm
- Abrichtgeschwindigkeit 100 – 300 mm/min
- Wirkbreite Abrichttrad 0.5 – 2.0 mm je nach Abrichtscheibentyp
- Schleifscheibendurchmesser 10 – 400 mm
- Bindungen Keramik/Kunstharz
- Korngrösse CBN/Diamant B/D46 – B/D251



DRESSER-Abrichtgerät

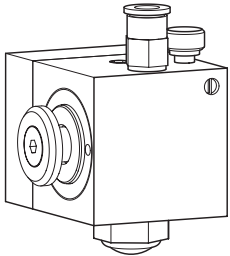

	Bezeichnung	Typ
	WEISS DRESSER-Abrichtgerät: ■ Inkl. Stahlplatte ■ Ohne Bremse und Abrichteinheit	15001

DRESSER-Abrichteinheiten

Auswahl der geeigneten Abrichteinheit für Maschinenart und Schleifscheibentyp

Einsatz	Schleifscheibe				Abrichteinheit
	Scheibentyp/-art	Körnung	Durchmesser	Breite	
■ Umfangseitiges Abrichten von Aussenschleifkörpern	Korundscheiben	80 – 120	20 – 400	200	Diamant-Abrichtrad Typ 15006
	Siliziumkarbidscheiben	80 – 120			
	CBN-Scheiben keramisch gebunden	46 – 181			
■ Umfangseitiges Abrichten von Aussenschleifkörpern ■ Einsatz bei hohen Abrichtzyklen	Korundscheiben	120 – 240	20 – 400	200	Diamant-Abrichtrad Typ 15007
	Siliziumkarbidscheiben	120 – 240			
	CBN-Scheiben keramisch gebunden	181 – 251			
■ Umfangseitiges Abrichten von Aussenschleifkörpern ■ Einsatz bei hohen Abrichtzyklen	CBN-Scheiben kunstharzgebunden	91 – 251	20 – 400	200	Diamant-Abrichtrad Typ 15275
■ Abrichten von Innenschleifkörpern ■ Einsatz bei hohen Abrichtzyklen	Korundscheiben	80 – 120	10 – 300	100	Diamant-Abrichttopf Typ 14259
	Siliziumkarbidscheiben	80 – 120			
	CBN-Scheiben keramisch gebunden	46 – 181			
■ Abrichten von Innenschleifkörpern ■ Einsatz bei kleineren bis mittleren Abrichtzyklen	Korundscheiben	60 – 120	10 – 300	100	Diamant-Abrichttopf Typ 11643
	Siliziumkarbidscheiben	60 – 120			
	CBN-Scheiben keramisch gebunden	46 – 181			
■ Umfang- und stirnseitiges Abrichten von Aussenschleifkörpern	Korundscheiben	80 – 120	20 – 400	200	Diamant-Abrichttopf Typ 15151
	Siliziumkarbidscheiben	80 – 120			
	CBN-Scheiben keramisch gebunden	46 – 181			
	CBN-Scheiben kunstharzgebunden	91 – 251	20 – 400	200	Diamant-Abrichttopf Typ 15276

Diamant-Abrichträder

	Bezeichnung	Bindung	Körnung	Typ
 Typ 15006	Diamant-Abrichtrad Ø35 x 2 x 7 D356	Metallbindung	D356	15006
 Typ 15007	Diamant-Abrichtrad Ø35 x 2 x 7 D151	Metallbindung	D151	15007
 Typ 15275	Diamant-Abrichtrad Ø35 x 2 x 7 D181	Keramikbindung	D181	15275

Fortsetzung siehe nächste Seite, Bestellbeispiel → Seite 3-69







**Diamant-Abrichttöpfe**

	Bezeichnung	Bindung	Körnung	Typ
 Typ 14259	Diamant-Abrichttopf Ø16 x 3 x 7 D356	Metallbindung	D356	14259
 Typ 11643	Diamant-Abrichttopf Ø16 x 1 x 7 D426	Galvanikbindung	D426	11643
 Typ 15151	Diamant-Abrichttopf Ø35 x 2 x 7 D356	Metallbindung	D356	15151
 Typ 15276	Diamant-Abrichttopf Ø35 x 2 x 7 D181	Keramikbindung	D181	15276

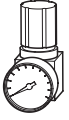
Zubehör und Ersatzteile sowie Bestellbeispiel siehe nächste Seite

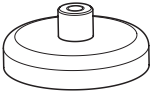
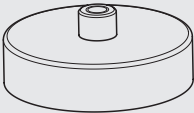
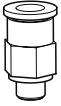

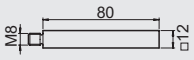
Zubehör und Ersatzteile für DRESSER

	Bezeichnung	Bemerkung	Typ
	Druckluftregler PNEUMAX	<ul style="list-style-type: none"> Innengewinde R 1/4" Max. Druck 8 bar 	13777
	Schalldämpfer	<ul style="list-style-type: none"> Metall-Ausführung Mit Drahtgeflecht Typ SFE Gewinde 1/8" 	15000
	Flachtopfmagnet	<ul style="list-style-type: none"> Ø63 mm, H = 14 mm 260 N für Druckluftregler 	13775
	Rutschfester Flachmagnet	<ul style="list-style-type: none"> Für Druckluftregler Ø66.5 mm mit Gewinde M5x7 	13776
	Quick-Star-Steckverbindung	<ul style="list-style-type: none"> QSM-M5-6 Gerader Anschluss 	12370
	Arretierungsstift	<ul style="list-style-type: none"> Für WEISS DRESSER 	15005
	Halter MK1	<ul style="list-style-type: none"> Für WEISS DRESSER Befestigung an Standardgrundplatte 	13639
	Halter 12x12	<ul style="list-style-type: none"> Für WEISS DRESSER Befestigung an Standardgrundplatte 	12266
	Pressluftschlauch	<ul style="list-style-type: none"> Für WEISS DRESSER Aussen-Ø6 mm 	16517

Bestellbeispiel

- WEISS DRESSER inkl. Stahlplatte **Typ 15001**
- Diamant-Abrichtrad Ø35 x 2 x7 D181 Keramikbindung **Typ 15275**
- Druckluftregler PNEUMAX **Typ 13777**
- Flachtopfmagnet für Druckluftregler Ø63 **Typ 13775**
- Pressluftschlauch zu WEISS DRESSER, Länge nach Angabe **Typ 16517**



Abrichtwelle für CBN- und Diamantscheiben

Rotierende Abrichtwerkzeuge

Produktmerkmale

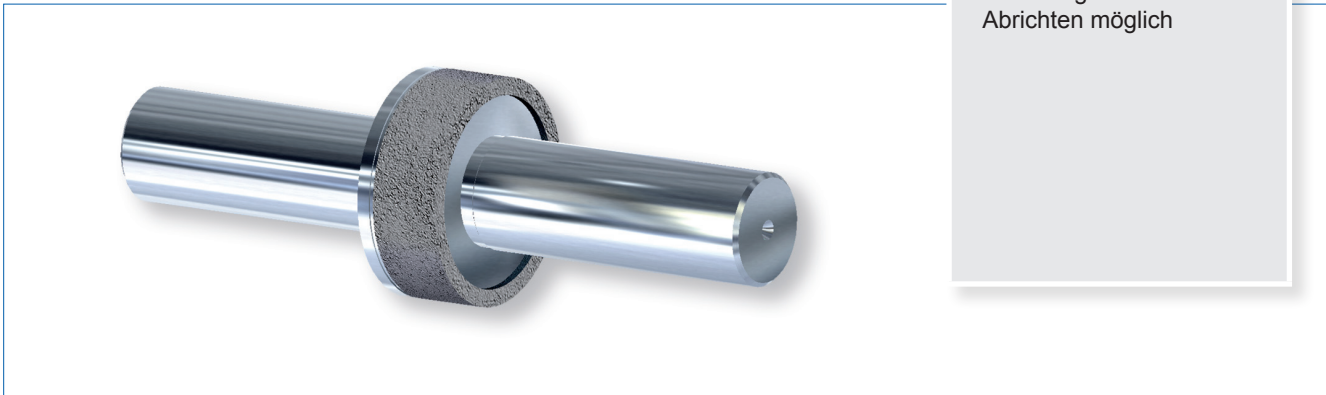

Vorteile im Überblick

- Einfache Anwendung
- Wiederbelegbar
- Stirnseitiges und seitliches Abrichten möglich

Produktmerkmale

Anwendung

- Rundschleifmaschine
- Abrichten von kunstharz- und keramischgebundenen CBN- und Diamantscheiben

Einsatz

- Aufspannung zwischen Spitzen
- Geschwindigkeit Schleifscheibe . . . ca. 25 m/s – 30 m/s
- Drehzahl Abrichtwelle ca. 150 U/min
- Abrichtzustellung:
CBN-Scheiben 0.002 mm/Überlauf
DIAMANT-Scheiben 0.001 mm/Überlauf

ACHTUNG

- Gute Kühlung während des Abrichtprozesses verlängert die Lebensdauer des Abrichtwerkzeuges erheblich. Bei kunstharzgebundenen CBN- und Diamantscheiben muss nach dem Abrichten der Schleifbelag an der Scheibe mittels Korundstein geöffnet werden.

Abrichtwelle für CBN- und Diamantscheiben

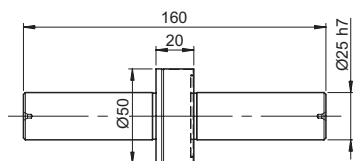

	Abmessung			Typ
	Welle [mm]	Diamantbelag [mm]	Körnung [µm]	
	Ø30 x 160	Ø50 x 16	D301	14612

Bestellbeispiel

- Abrichtwelle D301, Typ 14612

Weitere Korngrößen auf Anfrage





Produktspektrum

Wendeplattenabrichter mit DIAPACT(PKD)
Haltebeispiele für Wendeplattenabrichter

→ Seite 3-73

→ Seite 3-75

Vorteile im Überblick

- Einsatz bei engen Platzverhältnissen
- Einsatz bei filigranen Konturen möglich
- Einfaches Wechselsystem

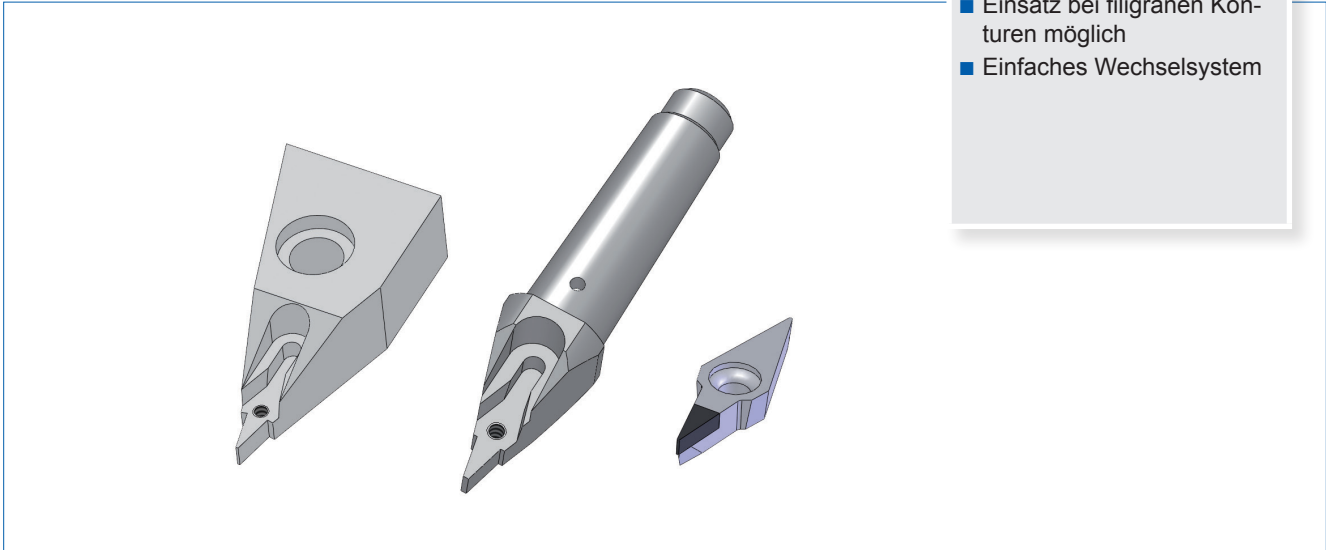

Produktmerkmale

- Diamant-Rohlinge hartgelötet auf HM-ISO-Schneidplattenträger
- Nachschleif- oder Nacherodierbar

Anwendungsbereiche

- Grundsätzlich können die DIAPACT (PKD)-Abrichter für die meisten Abrichtprozesse eingesetzt werden. Bei erhöhtem Verschleiss empfehlen wir die CVD-Diamant-Ausführung.
- Korund und Siliziumkarbidscheiben
- Rundschleifmaschinen
- Werkzeugschleifmaschinen
- Bis Scheibenhärte 0
- Körnung 46 - 220

Sortenbezeichnung: A050 - DIAPACT (PKD)-Ausführung
 A060 - CVD-Diamant-Ausführung

Einsatzbedingungen

- Anstellwinkel des Abrichters ist 0°
- Ausreichende Kühlung erhöht die Lebensdauer des Abrichters.
- Abrichtzustellung: 0.01 - 0.03 mm
- Abrichtvorschub: 0.05 - 0.2 mm/U



Wendeplattenabrichter mit DIAPACT(PKD)

■ Halterbeispiele → Seite 3-75

Typ WA

	a	R [mm]	Typ
	25°	0	WA25-000 A0..
		0.125	WA25-125 A0..
		0.2	WA25-200 A0..
		0.25	WA25-250 A0..
	15°	0	WA15-000 A0..
		0.125	WA15-125 A0..
		0.2	WA15-200 A0..
		0.25	WA15-250 A0..
	8°	0	WA8-000 A0..
		0.125	WA8-125 A0..
		0.2	WA8-200 A0..
		0.25	WA8-250 A0..

Bestellinformationen

Verfügbare Ausführungen

	DIAPACT (PKD)	CVD-Diamant
Bestell-Code	A050	A060
Verfügbarkeit	<input type="radio"/>	<input type="radio"/>

Auf Anfrage, bitte Wunschtermin für die Lieferung angeben

Bestellbeispiel für:
Typ:WA25-200 A050

■ tt.mm.jj (Wunschtermin)

Andere Ausführungen auf Anfrage



Wendeplattenabrichter Halter

Stehende Abrichtwerkzeuge

Wendeplattenhalter Typ „Kellenberger“

- Hinweis: Halter gehen auf Kellenberger Schleifmaschinen

Typ WAHK....

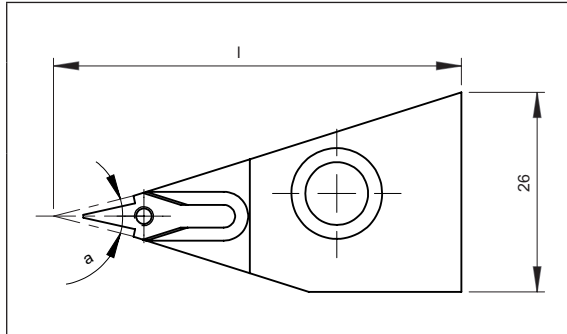

a [mm]	Typ
25°	WAHK 25
15°	WAHK 15
8°	WAHK 8

Bestellinformationen

Bestellbeispiel für:

Typ: WAHK 15

Weitere Halter auf Anfrage



Halterbeispiele für Wendepplattenabrichter

Klemmhalter zylindrisch

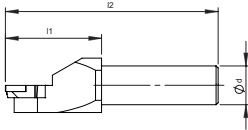
	Ød [mm]	Winkel a	l1 [mm]	l2 [mm]	Typ
	8	8	25°	26	56
15°			WAHZ-8-15		
8°			WAHZ-8-8		
10	10	25°	26	56	WAHZ-10-25
		15°			WAHZ-10-15
		8°			WAHZ-10-8
12	12	25°	26	56	WAHZ-12-25
		15°			WAHZ-12-15
		8°			WAHZ-12-8

Klemmhalter Morse Konus

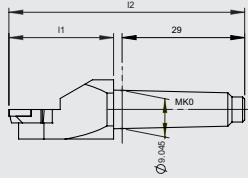
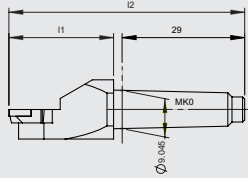
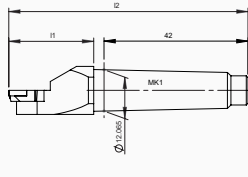
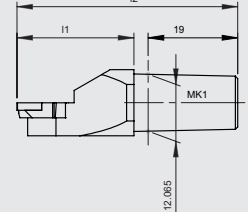
	Bezeichnung	Winkel a	l1 [mm]	l2 [mm]	Typ
	Morse Konus 0	25°	26	56	WAH-MK0-25
		15°			WAH-MK0-15
		8°			WAH-MK0-8
	Morse Konus 1 lang	25°	26	70	WAH-MK1L-25
		15°			WAH-MK1L-15
		8°			WAH-MK1L-8
	Morse Konus 1 kurz	25°	26	47	WAH-MK1K-25
		15°			WAH-MK1K-15
		8°			WAH-MK1K-8

Bestellinformationen

Bestellbeispiel für:
Klemmhalter WAHZ-10-25

- Wendepplattenklemmhalter Ø10 für Abrichtplatte 25°

Weitere Halter nach Anfrage



Aufnahme Kellenberger Schleifmaschine

Spezialaufnahmen Schleifmaschinen

	Maschine	Winkel α	Winkel β	Wendeplattenabrichter Typ	Bestellnummer
	Kellenberger	70°	25°	WAH-25	26357-WAH25
			15°	WAH-15	26357-WAH15

Bestellinformationen

Bestellbeispiel für:

Aufnahme 26357

- Aufnahme 26357
- 2 Wendeplattenabrichter z.B. Typ WA25-125 A050 (Siehe ab Seite 3-73)

Weitere Halter nach Angabe





Produktspektrum

M-Dresser Typen

→ Seite 3-79

Vorteile im Überblick

- Einfache Anwendung
- Bestes Preis - Leistungsverhältnis
- extrem kurzer Abrichteinsatz
- Abrichten auf der Maschine → bester Rundlauf
- Maschinenschonendes Abrichten

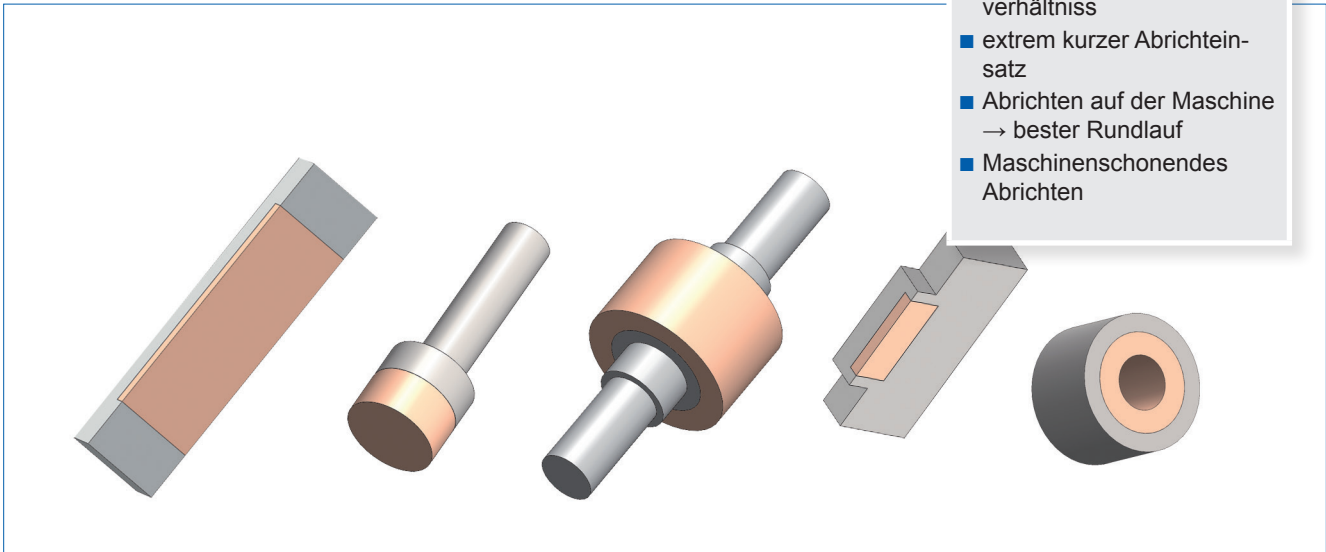

Produktmerkmale

- Einfacher Einsatz
- Kein nachträgliches „öffnen“ der Scheiben mehr nötig
- kurze Abrichtzeit - geringe Stillstandzeit der Schleifmaschine

Anwendungsbereiche

- Für das Abrichten von Diamant- und CBN-Schleifscheiben
- Rundschleifmaschinen
- Werkzeugschleifmaschinen
- Innenschleifen
- bis Konzentration C100
- keramisch- und kunstharz- gebunde Schleifscheiben
- Nicht geeignet für metallische Bindungen

Einsatzbedingungen

- Normales Überschleifen des entsprechenden Dressers
- Ausreichende Kühlung erhöht die Lebensdauer des Abrichters.

Abrichtparameter

Scheibengröße mm	Zustelltiefe mm	Schnittgeschwindigkeit Scheibe	Tischgeschwindigkeit	Tischbewegung Quer
170	0.005	10 m/s bis 13 m/s	10 m/min	200 mm/min
270	0.004		bis	bis
400	0.002		15 m/min	300 mm/min



M-Dresser

Form	Anwendung	Abmasse B x H x L	Typ	Artikel Nr.
	Flachschleifen	24 x 15 x 100	MDW 1	22176
		24 x 23 x 155	MDW 2	22177
		24 x 23 x 220	MDW 3	22178
	Rundschleifen	Ø30 x 20 x 80	MDW 4	22179
		Ø30 x 30 x 130	MDW 5	22180
	Innenschleifen	Ø30 x 12 x 20	MDW 6	22181
		Ø48 x 24 x 20	MDW 7	22182
		Ø70 x 40 x 20	MDW 8	22183
	Werkzeugschleifen	20 x Ø11 x 55	MDW 9	22184
	Seitenflächenschleifen	45 x 15 x 90	MDW 10	22185
	Universalschleifen	Ø11 x 20 x 50	MDW 11	22186

Bestellinformationen

Bestellbeispiel für:
M-Dresser

■ M-Dresser MDW1 Art: 22176

Weitere M-Dresser nach Anfrage



Diamant- und CBN-Schleifscheiben



- Formenübersicht und Anwendungsbereich 4-2
- Einleitung 4-4
- Werkzeugschleifen 4-12
- Flachsleifen 4-18
- Profilschleifen 4-22
- Innenschleifen 4-24
- Schleifstifte 4-26
- Aussenrundsleifen 4-28
- Trennschleifen 4-30
- Nutenschleifen 4-32
- Sonderausführungen 4-34
- Fragebogen zur Bestimmung von
Diamant- und CBN-Scheiben 4-35

Korund- und Siliziumkarbidscheiben



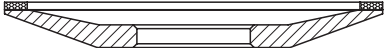
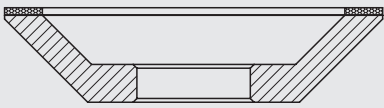
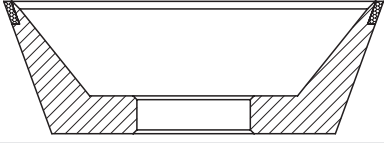
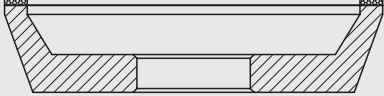
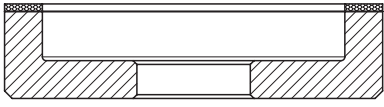
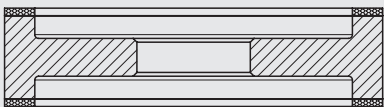
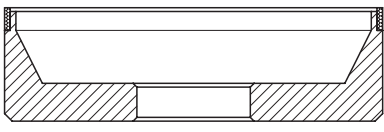
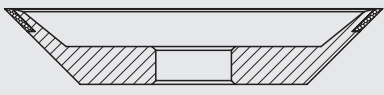
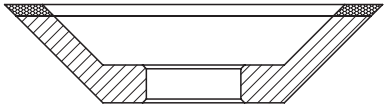

- Produktübersicht 4-36
- Produktion 4-37
- Formen und Profile 4-38
- Sicherheit 4-42
- Schleifanwendungen 4-43
- Spezifikation 4-46
 - Schleifmittel 4-46
 - Körnung 4-47
 - Härte 4-47
 - Gefüge 4-47
 - Bindung 4-47
- Lagerprogramm Deutschland 4-48
 - Schleifbockscheiben 4-48
 - Werkzeug-Schleifscheiben 4-53
 - Flachsleifen 4-55
 - Sägeschärf scheiben 4-56

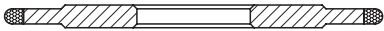
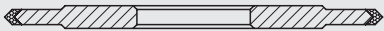
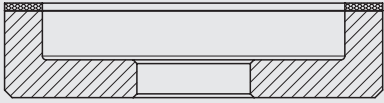
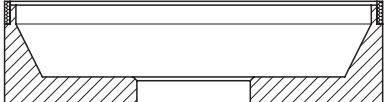

Formenübersicht und Anwendungsbereiche

Scheibentyp	Werkzeugschleifen Freiflächen	Anwendung Werkzeugschleifen Spanleitstufen	Werkzeugschleifen Spanflächen
4A2 	→ 4-13	→ 4-13	→ 4-13
12A2-20° 	→ 4-13	→ 4-13	→ 4-13
12A2-45° 	→ 4-13	→ 4-13	→ 4-13
11V9 	→ 4-13	→ 4-13	→ 4-13
11A2 	→ 4-15	→ 4-15	-
6A2 	→ 4-15	→ 4-15	-
9A3 	→ 4-15	→ 4-15	-
6A9 	→ 4-15	→ 4-15	-
12V9 	-	-	→ 4-17
12V2 	-	-	→ 4-17
4ET9 	-	-	→ 4-17
4BT9 	-	-	→ 4-17

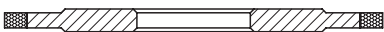

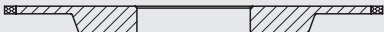
Scheibentyp	Anwendung					
	Nut- schleifen	Trenn- schleifen	Aussenrund- schleifen	Innen- schleifen	Profil- schleifen	Flach- schleifen
1FF1 	-	-	-	-	→ 4-23	-
14F1 	-	-	-	-	→ 4-23	-
14EE1 	-	-	-	-	→ 4-23	-
14V1 	-	-	-	-	→ 4-23	-
6A2 	-	-	-	-	-	→ 4-19
6A9 	-	-	-	-	-	→ 4-19
1A1 	-	-	→ 4-29	→ 4-25	-	→ 4-21
14A1 	→ 4-33	-	→ 4-29	-	-	→ 4-21
1A1W 	-	-	-	→ 4-27	-	-
1A1R 	→ 4-33	→ 4-31	-	-	-	-
3A1 	→ 4-33	→ 4-31	-	-	-	-



Einführung

Teil 1

Im ersten Teil dieses Kapitels werden die wesentlichsten Eigenschaften, Zusammenhänge und Auswirkungen der einzelnen Scheibenkomponenten erklärt. Dies soll dem Anwender ein grösseres Wissen und ein besseres Verständnis für den gezielten wirtschaftlichen Einsatz von Diamant- und CBN-Schleifscheiben vermitteln.

Teil 2

Im zweiten Teil werden dann die verschiedenen Scheibentypen und -abmessungen sowie die Anwendungsempfehlungen für Diamant- und CBN-Schleifscheiben dargestellt.

Eigenschaften von Diamant und CBN

► **Diamant** eignet sich wegen seiner grossen Härte am besten zur Bearbeitung von kurzspanenden Werkstoffen wie Hartmetall, Keramik, Glas, Gestein usw. Seine Wärmeempfindlichkeit einerseits und seine chemische Reaktion auf Eisen im Bereich üblicher Bearbeitungstemperaturen andererseits beschränken den Einsatz von Diamant auf Nicht-eisenwerkstoffe.

► **CBN** eignet sich hingegen bestens für die Bearbeitung von langspanenden Werkstoffen wie Werkzeugstählen, HSS, hochlegierten Stählen usw. in gehärtetem Zustand mit mindestens 45 HRC. Die gute Wärmebeständigkeit von CBN in Kombination mit seiner grossen Härte ermöglichen erst das wirtschaftliche Schleifen im Bereich höherer Bearbeitungstemperaturen dieser Stähle.

Physikalische Eigenschaften

Die unterschiedlichen physikalischen Eigenschaften sind in den folgenden Tabellen und Abbildungen dargestellt:

Physikalische Eigenschaften

		► Diamant	► CBN
Dichte	g/cm ³	3.52	3.47
Härte	Knoop	7.000	4.700
	Mohs	10	9.9
Max. Wärmebeständigkeit	°C	650	1.400

Knoopische Härte [kp/mm²]

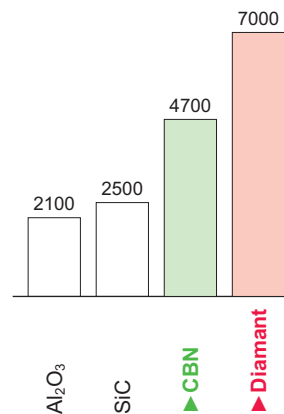

Wärmebeständigkeit [°C]

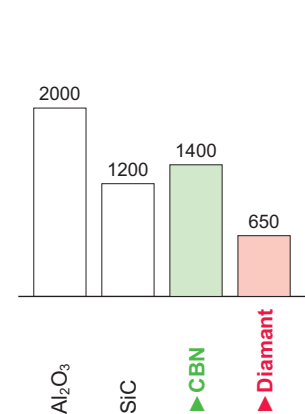

Hier wird folgendes deutlich:

Obwohl der Diamant wesentlich härter als CBN ist, muss wegen seiner niedrigeren Wärmebeständigkeit für ausreichende Kühlung gesorgt werden, so dass die Temperatur im Bereich des Bearbeitungsvorganges so niedrig wie möglich ist. Die hohen Temperaturen, die bei der Bearbeitung langspanender Werkstoffe auftreten, können dem CBN zwar nichts anhaben, eine Kühlung ist jedoch auch hier von Vorteil.

Anwendungsbereiche

In der nebenstehenden Tabelle sind die üblichen Werkstoffe, welche mit Diamant und CBN bearbeitet werden, aufgeführt.

Leider geschieht es immer wieder, dass zur Bearbeitung eines Werkstoffes die falsche Kornart gewählt wird. Das Ergebnis ist entsprechend unbefriedigend.

Anwendungsbereiche

► Diamant	► CBN
<ul style="list-style-type: none"> ■ Hartmetall ■ Hartmetall/Stahlverbund ■ Keramik ■ Glas ■ Gestein ■ Beton ■ Harte Kunststoffe 	<p>Für alle Werkstoffe gilt eine Mindesthärte von HRC 45:</p> <ul style="list-style-type: none"> ■ Werkzeugstahl ■ HSS ■ Hochlegierte Stähle ■ Kugellagerstahl ■ Chromstahl ■ Stähle auf Kobalt- und Nickelbasis



Definition der Schleifscheibe

Diamant- und CBN-Scheiben bestehen aus einem Kunststoff-, Aluminium- oder Stahlkörper, der mit dem eigentlichen Schleifbelag verbunden ist. Körper und Belag haben verschiedene Formen und Abmessungen. Zudem bestehen beim Belag verschiedene Möglichkeiten der Platzierung in Bezug zum Körper.

Wir folgen mit unserer Bezeichnung der FEPA-Norm, die sich international bewährt und durchgesetzt hat. Die FEPA-Norm berücksichtigt nahezu alle gebräuchlichen Scheibentypen.

Eine Übersicht unseres Standardprogrammes nach FEPA-Norm ist auf [Seite 4-6](#) abgebildet. Weitere Formen und Abmessungen auf Anfrage.

Beispiel zum Definieren einer Schleifscheibe

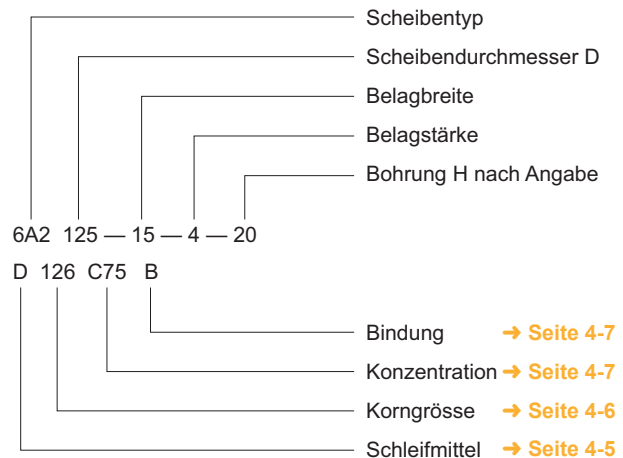

Scheibentypen

Der richtige Scheibentyp ergibt sich normalerweise aus Form und Abmessungen des Werkstückes sowie durch die Maschine und den Bearbeitungsvorgang.

Sollte jedoch eine Topf- oder Tellerscheibe möglich sein, ist aus Gründen grösserer Stabilität die Topfscheibe vorzuziehen. Tellerscheiben sind schwingungsempfindlicher.

Beim Stirnschleifen mit einer Topfscheibe entsteht eine grosse Kontaktfläche zwischen Werkstück und Scheibe. Dadurch verteilt sich der Schleifdruck und die Schleifarbeit auf viele Schleifkörner. Im Vergleich zum Umfangschleifen entsteht eine feinere Oberfläche, eine höhere Produktivität und dadurch niedrigere Kosten.

Schleifmittel

Aus der grossen Anzahl unterschiedlicher Diamant- und CBN-Körner haben wir die sechs gebräuchlichsten Kornarten gewählt und in der nebenstehenden Tabelle dargestellt.

Schleifscheiben mit nickelummanteltem Diamant- oder CBN-Korn haben im Allgemeinen eine höhere Lebensdauer und Profilhaltigkeit, jedoch nicht dieselbe Schneidfrequenz wie unummanteltes Korn.

	Schleifmitteltyp	Kunststoffbindung	Metallbindung
▲ Diamant	D ■ Synthetischer Diamant ■ Unummantelt	✓	✓
	DG ■ Synthetischer Diamant ■ Unummantelt	–	✓
	DK ■ Synthetischer Diamant ■ Kupferummantelt	✓	–
	DN ■ Synthetischer Diamant ■ Nickelummantelt	✓	–
▲ CBN	B ■ CBN ■ Nickelummantelt	✓	–
	BM ■ CBN ■ Unummantelt	–	✓



Korngrösse

Bestimmung der Korngrösse

Die Korngrösse wird bei D (Diamant)-Körnungen und B (CBN)-Körnungen nach der FEPA-Norm in μm angegeben. Das heisst, dass z. B. der maximale Korndurchmesser von D126 0.126 mm beträgt.

Zudem haben wir in der nebenstehenden Tabelle noch die USA-Norm ASTM (mesh) aufgeführt, welche die Anzahl Maschen pro Zoll des Sortiersiebs angibt.

Korngrösse [μm]	WEISS	FEPA	USA std ASTM E 11	DIN ISO 6106
425 – 300	427	427	40/50	D 350
250 – 180	252	252	60/80	–
180 – 150	181	181	80/100	D 180
150 – 125	151	151	100/120	D 140
125 – 106	126	126	120/140	D 110
106 – 90	107	107	140/170	D 90
90 – 75	91	91	170/200	D 90
75 – 63	76	76	200/230	D 65
63 – 53	64	64	230/270	D 55
53 – 45	54	54	270/325	D 45
45 – 38	46	46	325/400	D 45
Mikrokörnungen für Feinst- und Läppschliff				
30 – 40	D 40			
20 – 30	D 25			
10 – 20	D 15			
8 – 15	D 10			
5 – 10	D 7	–	–	–
4 – 8	D 5			
2 – 4	D 3			
1 – 2	D 1			
< 1	D 0.7			

Auswahl der Körnung

Die Körnung sollte so grob gewählt werden, wie es die geforderte Oberflächengüte des Werkstücks noch zulässt. Je feiner die Körnung, desto niedriger wird im Allgemeinen die Abtragsleistung und die Lebensdauer der Scheibe (siehe nebenstehende Abbildung).

Es ist zu beachten, dass nicht nur die Korngrösse die Oberflächengüte des Werkstücks beeinflusst, sondern auch die Stabilität der Maschine, die Schnittdaten sowie die Grösse der Kontaktfläche.

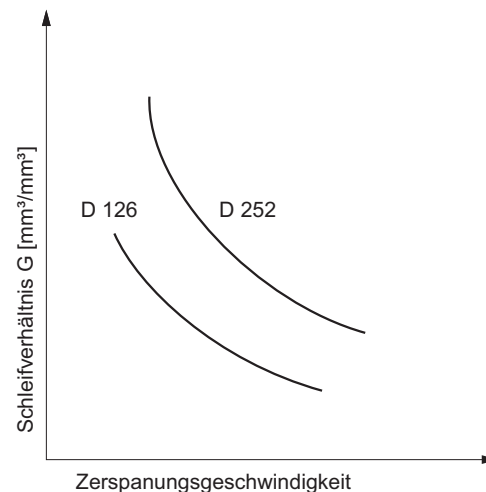

Verhältnis Körnung und Anzahl der Körner

Bei hoher Anforderung an die Kanten- und Profilhaltigkeit empfiehlt es sich, feinere Korngrössen zu verwenden. Je feiner die Korngrösse, desto höher die Anzahl der Körner pro Karat (1 Karat = 0.2 g).

Korngrösse [μm]	Anzahl Körner per Karat
427	2.100
181	10.400
151	19.000
91	83.000
54	420.000
46	620.000



Konzentration

Die Eigenschaften der Schleifscheibe können durch die Menge der Körnung verändert werden. Die Menge von Diamant- und CBN-Körnung ist nach FEPA-Norm in Konzentration angegeben. Konzentration C 100 entspricht 4.4 Karat (1 Karat = 0.2 g) Körnung je cm³ Belagsvolumen. Das sind ca. 25 % Schleifmittel.

Um den Preis einer Scheibe so niedrig wie möglich zu halten, wird häufig eine zu niedrige Konzentration gewählt. Dadurch wird die Kanten- und Profilhaltigkeit vermindert, die einzelnen Schleifkörner brechen zu früh aus der Bindung, der Verschleiss wird hoch und damit eine unbefriedigende Wirtschaftlichkeit erreicht.

Die folgende Tabelle zeigt eine schematische Darstellung der verschiedenen Konzentrationen:

	niedrig		mittel		hoch	
Konzentration	C 25 – C 50		C 75 – C 100		C 125 – C 150	
Karat/cm³	1.1	2.2	3.3	4.4	5.5	6.6
ca. Vol. %	16	13	19	25	31	37

Bestimmung der Konzentration

Einige der wesentlichen Kriterien sollen die Bestimmung der Konzentration erleichtern:

- Niedrige Konzentration C 25 bis C 50
 - grosse Belagsbreite
 - feine Körnung
- Mittlere Konzentration C 75 bis C 100
 - allgemeines Rund- und Flachsleifen
 - Werkzeugschleifen
 - weiche Bindung
- Höhere Konzentration C 125 bis C 150
 - gröbere Körnung
 - gute Kanten- und Profilhaltigkeit
 - harte Bindung

Bindung

Eine weitere Komponente, die die Leistung einer Schleifscheibe ganz wesentlich beeinflusst, ist die Bindung. Die Aufgabe einer Bindung besteht darin, dem Schleifkorn unter den jeweils gegebenen Bedingungen den optimalen Halt und dabei den anfallenden Spänen noch genügend Raum zu geben.

Es stehen 4 Bindungsgrundarten zu Verfügung:

- Kunststoffbindung
- Metallbindung
- Keramische Bindung
- Galvanische Bindung

Kunststoffbindung

Die gebräuchlichste Bindung für Diamant- und CBN-Scheiben ist die Kunststoffbindung. Sowohl Aussenrund-, Innenrund- und Flachsleifen als auch nahezu alle Werkzeugschleifoperationen werden hauptsächlich mit kunststoffgebundenen Scheiben ausgeführt. Diese Bindung vereinigt einige sehr gute Eigenschaften, wie gute Schleiffreudigkeit, niedrigen Schleifdruck, geringe Wärmeentwicklung, lange Lebensdauer und niedrigen Preis. Dies alles zusammen gibt eine hohe Wirtschaftlichkeit.

In nebenstehender Tabelle zeigen wir unsere Kunststoffbindungen, abhängig von Bearbeitungsart und Scheibentyp.

Kunststoffbindung		Anwendungsbereich	Nassschliff	Trockenschliff
▶ Diamant	▶ CBN			
B	B	Alle Scheibentypen	✓	✓
B2A	B3	Umfangsscheiben z. B. 1A1, 14A1	✓	–
B3A	B3	Topf- und Tellerscheiben	✓	–
B4	B3	Trennscheiben	✓	–
B6	B6	Profilscheiben	✓	–
B2A	B3	Innenschleifen	✓	–
EB9	–	Für Körnungen von D 40 bis D 64	✓	–
B7	–	Für Körnungen feiner als D 40	✓	–
–	B8	Werkzeugschleifen mit Topf- und Tellerscheiben, sehr schleifreudig	–	✓



Metallbindung

Die Metallbindung ist in den häufigsten Fällen auf einer Bronze-Basis aufgebaut. Ihre besonderen Vorzüge sind eine gute Kanten- und Profilhaltigkeit, und sie wird am wirtschaftlichsten zum Schleifen von Keramik, Glas, Gestein, Beton usw. im Nassschliff eingesetzt.

Zum Schleifen metallischer Werkstoffe empfiehlt sich die Metallbindung im Wesentlichen für das Profil- und Tief-schleifen. In nebenstehender Tabelle zeigen wir unsere Metallbindungen abhängig von Bearbeitungsart und Scheibentypen.

Metallbindung		Anwendungsbereich	Nass-schliff
▶ Diamant	▶ CBN		
M 27	M 27	Alle Scheibentypen und Operationen	✓
M 26	M 26	Alle Scheibentypen, jedoch weicher als M 27	✓
M 52	M 52	Profilscheiben härter als M 27	✓
M 6	–	Zum Schleifen von Spanleitstufen und ähnlichem in Hartmetall	✓

Keramische Bindung

Die keramische Bindung wird hauptsächlich in Verbindung mit CBN-Körnung zur Bearbeitung langspanender Werkstoffe verwendet. Diese Bindung gibt mehr Spanraum für lange Späne als die oben genannten Bindungen. Eine weitere positive Eigenschaft der keramischen Bindung ist, dass sie einfacher abzurichten ist als eine Kunststoff- oder Metallbindung. Im Allgemeinen können dieselben Abrichtmethoden wie für keramische Scheiben in Aluminiumoxid oder Siliziumkarbid angewendet werden.

Keramisch gebundene Scheiben werden im Wesentlichen in der Grossserienfertigung eingesetzt. Die Wahl der Zusammensetzung sollte zusammen mit einem unserer Techniker getroffen werden.

Galvanische Bindung

Bei der galvanischen Bindung wird das Diamant- bzw. CBN-Korn mit einer im galvanischen Verfahren aufgetragenen Nickelschicht mit dem Trägerkörper verbunden. Diese Bindung ist sehr offen, schleift aggressiv und eignet sich bei geeigneter Kornwahl zum Schleifen von Stahl, Hartmetall, Glas, Keramik und Kunststoff. Die galvanische Bindung wird im Allgemeinen einschichtig aufgebracht, d.h. die Belagstärke entspricht in etwa der Kornstärke und kann somit bei Abnutzung nicht mehr abgerichtet oder nachprofiliert werden. Bei grösseren Scheiben ist ein Neubelegen jedoch wirtschaftlich.

Die Abmessungen der Schleifscheibe

Die Abmessung einer Schleifscheibe ist in Bezug auf ihre Leistung von gleicher Wichtigkeit wie Schleifmittel, Korngrösse und Bindung.

Scheibendurchmesser

Der Scheibendurchmesser sollte unter Berücksichtigung der empfohlenen Schnittgeschwindigkeit v so gross wie möglich gewählt werden.

Belagbreite

Die Belagbreite ist in Bezug auf Leistungsfähigkeit und Produktivität einer Scheibe von grosser Bedeutung. Beim Flach- oder Rundschleifen mit Scheiben der Typen 1A1 bzw. 14A1 steht die Belagbreite in unmittelbarem Zusammenhang mit der Spanabtragsleistung per Zeiteinheit. Die Stabilität von Werkstück, Spannvorrichtung und Maschine, sowie die Leistung der Maschine selbst, grenzen die Belagbreite ein. Beim Stirnschleifen mit Scheiben der Typen 12A2, 11V9, 6A9 usw. empfiehlt es sich eher, einen relativ schmalen Belag zu wählen.

Beachten Sie bitte folgende Faustregel:

Grosse Belagbreite	Kleine Belagbreite
Feinere Oberfläche	Gröbere Oberfläche
Längere Lebensdauer	Kürzere Lebensdauer
Höherer Schleifdruck	Geringerer Schleifdruck
Grössere Wärmeentwicklung	Kleinere Wärmeentwicklung

Eintauchtiefe

Beim Werkzeugschleifen sollte die Belagbreite wesentlich kleiner als die Eintauchtiefe der Scheibe an der Werkzeugschneide sein. Die nebenstehende Abbildung macht diesen Punkt deutlich.

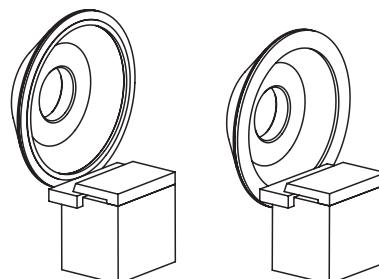
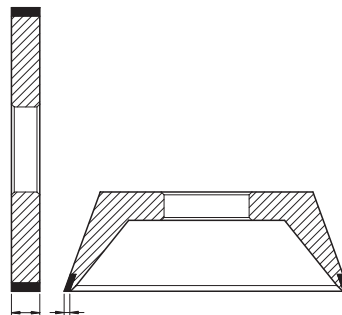



Belagstärke

Schleiftechnisch ist es völlig uninteressant, ob mit einer grossen oder kleinen Belagstärke gearbeitet wird. Wichtig für die Wahl ist nur, wie und wie häufig eine Scheibe im Einsatz ist. Die von der Belagstärke unabhängigen fixen Herstellungskosten ergeben z. B. bei einer Belagstärke von 6 mm einen wesentlich niedrigeren Preis pro mm als bei 1 mm Belagstärke. Bei grossem Scheibenverbrauch ist es am wirtschaftlichsten, mit der grösstmöglichen Belagstärke zu arbeiten. Besteht die Gefahr, dass durch unsachgemässe Behandlung die Scheibe zu Bruch gehen könnte, sind kleinere Belagstärken angezeigt.

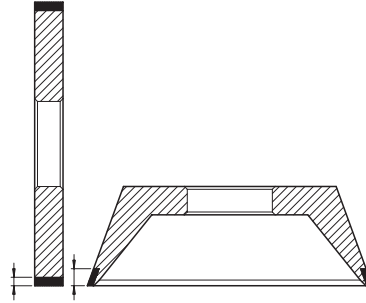

Montage und „Einschleifen“ der Schleifscheiben

Für die Lebensdauer und Wirtschaftlichkeit einer Diamant- oder CBN-Scheibe ist eine sorgfältige Montage und bei grossen Scheiben das Einschleifen von grosser Wichtigkeit. Es empfiehlt sich, folgende Punkte zu beachten:

Montage auf einen Flansch

- Der Flansch sollte in gutem Zustand sein und einen tadellosen Rund- und Planlauf auf der Schleifspindel haben.
- Die Scheibe auf dem Flansch leicht anziehen und auf Rund- und Planlauf kontrollieren.
- Der Rund- bzw. Planlauffehler des Belages darf maximal 0.02 mm betragen. Erst wenn diese Werte erreicht oder unterschritten sind, kann die Scheibe auf dem Flansch fest angezogen werden.
- Nach dem Justieren nochmals den Rund- bzw. Planlauf kontrollieren.

Auswuchten

- Je nach Gewicht einer Scheibe sollte ab Durchmesser 150 und grösser ausgewuchtet werden. Sorgfältiges statisches Auswuchten ist in den meisten Fällen ausreichend.
- Bei kleiner Scheibe ist das Auswuchten nicht unbedingt erforderlich, jedoch trotzdem von Vorteil.
- Je besser eine Scheibe ausgewuchtet ist, desto besser das Schleifergebnis und desto höher die Wirtschaftlichkeit.

Es empfiehlt sich, eine derart vorbereitete Scheibe die ganze Lebensdauer auf ihrem Flansch zu belassen.



Auswuchten einer Scheibe



Abrichten und Öffnen

Die Scheibe sollte nun nach der Flanschmontage und dem Auswuchten auf völligen Rund- bzw. Planlauf des Belages abgerichtet werden.

► Diamant

Diamantscheiben werden am vorteilhaftesten mit einer „gebremsten“ Siliziumkarbidscheibe abgerichtet. Auf diese Weise wird die Bindung abgeschliffen, bis die Scheibe die gewünschte Form hat. Dazu wird die gebremste Abrichtscheibe ca. 15 Grad schräg zur Diamantscheibe auf die Magnetplatte gespannt. Während des Anfahrens muss die Abrichtscheibe von Hand mitgedreht werden, bis die Diamantscheibe greift und den Antrieb übernimmt. Die Zustellung sollte pro Hub ca. 0.01 bis 0.03 mm betragen und muss so oft wiederholt werden, bis die Diamantscheibe an der ganzen Umfang- bzw. Stirnfläche absolut Rund- bzw. Planlauf aufweist. Danach sind kunststoffgebundene Scheiben direkt verwendbar. Metallgebundene Scheiben müssen jedoch vor einem Einsatz noch mit einem feinkörnigen, weichen Abziehstein geöffnet werden.

Topf- und Tellerscheiben können auch auf einer Stahlplatte, welche mit Siliziumkarbid in der Körnung von 80 – 120 µm bestreut ist, mit mässigem Druck unter kreisender Bewegung von Hand abgerichtet und geöffnet werden. Bei diesem Verfahren ist besonders auf Parallelität des Belages zur Anlagefläche der Scheibe zu achten.

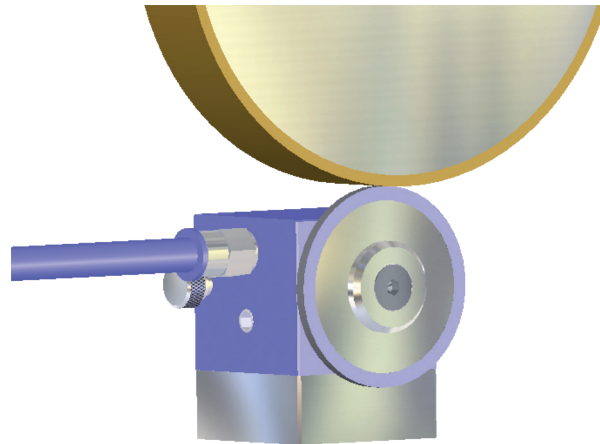

Abrichten mit einer gebremsten Siliziumkarbidscheibe

► CBN

CBN-Scheiben können auf mehrere Arten abgerichtet werden:

- Mit „gebremster“ Siliziumkarbidscheibe wie Diamantscheiben (siehe oben).
- Mit einem Diamant-Aggregat AGD 91 oder AGD 126 unter reichlicher Zufuhr von Kühlmittel. Die Zustellung sollte pro Hub ca. 0.002 mm bis 0.003 mm betragen bei hohem Abrichtvorschub.
- Mit einer angetriebenen, metallgebundenen Diamantscheibe unter reichlicher Zufuhr von Kühlmittel.
- Mit einer Stahlplatte in weichem Zustand, z. B. St 37 oder St 50. Stahlplatte auf den Magneten spannen, bei nur geringer Kühlmittelzufuhr und einer Zustellung von 0.02 mm bis 0.03 mm die Scheibe in axialer Richtung über die Stahlplatte ziehen. Diese Methode ist jedoch nur bei kunststoffgebundenen Scheiben möglich. Eine auf diese Art abgerichtete Scheibe ist auch bereits geöffnet.

Wurde eine CBN-Scheibe mit einer der drei ersten Methoden abgerichtet, ist ein nachträgliches Öffnen der Bindung unbedingt notwendig. Um sicherzugehen, dass genügend Spanraum vorhanden ist, sollte kontrolliert werden, ob sich die einzelnen Schleifkörner deutlich vom Belag abheben.

Öffnen der Bindung

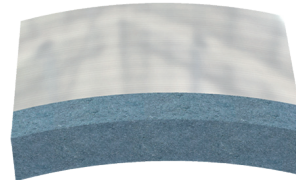

Abgerichtet, jedoch nicht geöffnet

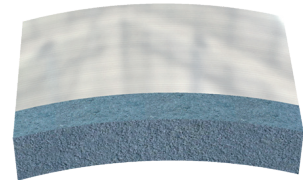

Nach dem Öffnen

Das Öffnen kann durch folgende Arten erreicht werden:

- Mit einem feinkörnigen, weichen Aluminiumoxid-Abziehstein bei Kühlmittelzufuhr. Wenn keine Kühlung vorhanden, den Abziehstein vorher 5 min in Wasser legen.
- Mit einem Polybondabziehstein ohne Kühlmittel.
- Mit weichem Stahl wie oben unter Punkt **D.** beschrieben.

Hinweis: Während des Schleifens ist darauf zu achten, dass die Scheiben nicht „zuschmieren“. Die Schleifkörnung sollte sich stets vom Belag abheben.

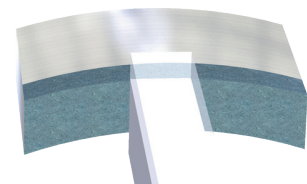



Checkliste bei Schleifproblemen

Die geschliffene Oberfläche ist zu grob

- Rund- und Planlauf des Schleifbelages prüfen
- Zustellung und Vorschub reduzieren
- Scheibe mit feinerer Körnung und/oder grösserer Belagbreite einsetzen
- Ist die Scheibe gut ausgewuchtet?

Die Standzeit ist zu gering

- Schnittgeschwindigkeit überprüfen, die angegebenen Werte einhalten
- Stabilität des Werkstückes und dessen Aufspannung prüfen
- Ist die Scheibe stabil genug?
- Erreicht das Kühlmittel wirklich die Schleifzone?
- Hat das Kühlmittel die angegebene Konzentration?
- Zustellung und Vorschub reduzieren
- Eine härtere Scheibe wählen

Die Scheibe schneidet ungenügend

- Schnittgeschwindigkeit überprüfen, die angegebenen Werte einhalten
- Das Spanvolumen (Zustellung und Vorschub) reduzieren
- Eine weichere Scheibe wählen
- Stabilität des Werkstückes und dessen Aufspannung prüfen
- Ist die Scheibe stabil genug?
- Erreicht das Kühlmittel wirklich die Schleifzone?
- Hat das Kühlmittel die angegebene Konzentration?



Werkzeugschleifen mit ► **Diamant**

Anwendungen

Spanflächen
Spanleitstufen
Freiflächen

Empfehlung der Zusammensetzung

Scheibenform	weichere Scheibe	Standard	härtere Scheibe
4A2	D 91 C 50 B	D 91 C 75 B	D 91 C 100 B
12A2-20°	D 91 C 50 B	D 91 C 75 B	D 91 C 100 B
12A2-45°	D 91 C 50 B	D 91 C 75 B	D 91 C 100 B
11V9	D 126 C 50 B	D 126 C 75 B	D 126 C 100 B

Bindung

- B für Trocken- und Nassschliff
- B3A . . . nur für Nassschliff

Weitere Bindungen → [Seite 4-7](#)

Scheibenform

Wenn es die Platzverhältnisse erlauben, sind die Topfscheiben (11V9 oder 12A2-45°) den weniger stabilen Tellerscheiben (4A2 oder 12A2-20°) vorzuziehen.

Die Stabilität einer Scheibe spielt in Bezug auf ihr Schleifverhalten eine grosse Rolle. Eine Tellerscheibe, z. B. 4A2 oder 12A2-20° ist formbedingt „weicher“ als eine vergleichbare Topfscheibe wie z. B. 11V9 oder 12A2-45°.

Für Tellerscheiben empfiehlt sich eher eine weichere Zusammensetzung.

Scheibendimension

- Durchmesser D
So gross wie möglich, unter Beachtung der empfohlenen Schnittgeschwindigkeit v.
- Breite W bzw. X
Je breiter der Belag ist, desto weicher sollte die Zusammensetzung gewählt werden. Die Belagbreite muss jedoch unbedingt schmaler sein als die Eintauchtiefe der zu schleifenden Spanfläche (→ [Seite 4-8](#)).

Schnittdaten

- Schnittgeschwindigkeit v
 - Trockenschliff: 10 – 15 m/s
 - Nassschliff: 15 – 20 m/s
- Vorschub s und Zustellung a müssen den Arbeitsbedingungen angepasst werden.

Werkzeugschleifen mit ► **CBN**

Anwendungen

Spanflächen
Spanleitstufen
Freiflächen

Empfehlung der Zusammensetzung

Scheibenform	weichere Scheibe	Standard	härtere Scheibe
4A2	B 126 C 50 B8	B 126 C 75 B8	B 126 C 100 B8
12A2-20°	B 126 C 50 B8	B 126 C 75 B8	B 126 C 100 B8
12A2-45°	B 126 C 50 B8	B 126 C 75 B8	B 126 C 100 B8
11V9	B 126 C 50 B8	B 126 C 75 B8	B 126 C 100 B8

Bindung

- B für Trocken- und Nassschliff
- B3 nur für Nassschliff
- B8 nur für Trockenschliff, sehr schleiffreudig

Weitere Bindungen → [Seite 4-7](#)

Scheibenform

Wenn es die Platzverhältnisse erlauben, sind die Topfscheiben (11V9 oder 12A2-45°) den weniger stabilen Tellerscheiben (4A2 oder 12A2-20°) vorzuziehen.

Die Stabilität einer Scheibe spielt in Bezug auf ihr Schleifverhalten eine grosse Rolle. Eine Tellerscheibe, z. B. 4A2 oder 12A2-20° ist formbedingt „weicher“ als eine vergleichbare Topfscheibe wie z. B. 11V9 oder 12A2-45°.

Für Tellerscheiben empfiehlt sich eher eine weichere Zusammensetzung.

Scheibendimension

- Durchmesser D
So gross wie möglich, unter Beachtung der empfohlenen Schnittgeschwindigkeit v.
- Breite W bzw. X
Je breiter der Belag ist, desto weicher sollte die Zusammensetzung gewählt werden. Die Belagbreite muss jedoch unbedingt schmaler sein als die Eintauchtiefe der zu schleifenden Spanfläche (→ [Seite 4-8](#)).

Schnittdaten

- Schnittgeschwindigkeit v: 25 – 35 m/s
Hinweis: niedrigere Werte ergeben einen höheren Scheibenverschleiss und eine schlechtere Oberfläche.
- Vorschub s und Zustellung a müssen den Arbeitsbedingungen angepasst werden.



Werkzeugschleifen mit Diamant oder CBN

Form 4A2

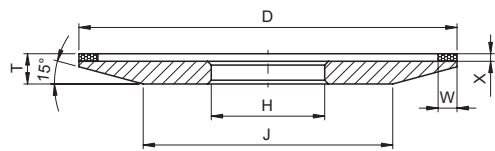

Belagstärke X [mm]: 2, 3 und 4
Bohrung H [mm]: nach Angabe

D [mm]	Abmessungen ¹⁾			J [mm]	Scheibenform
	W [mm]	T-X [mm]			
75	3 / 5	6		42	4A2
100	3 / 5	6		66	4A2
125	4 / 6	7		84	4A2
150	4 / 6	9		94	4A2

Form 11V9

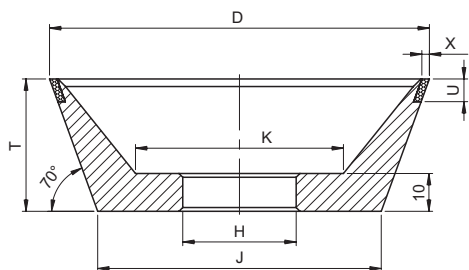

Belagstärke X [mm]: 1.5, 2 und 3
Bohrung H [mm]: nach Angabe

D [mm]	Abmessungen ¹⁾				J [mm]	Scheibenform
	U [mm]	T [mm]	K [mm]			
75	6 / 10	30	40		53	11V9
100	6 / 10	35	55		75	11V9
125	6 / 10	40	75		96	11V9
150	6 / 10	50	90		114	11V9

Form 12A2 | S = 20°

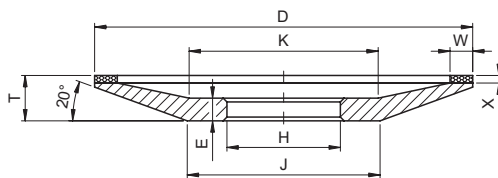

Belagstärke X [mm]: 2, 3 und 4
Bohrung H [mm]: nach Angabe

D [mm]	Abmessungen ¹⁾					
	W [mm]	T-X [mm]	E [mm]	K [mm]	J [mm]	Scheibenform
75	3 / 6 / 10	8	5	33	37	12A2-20°
100	3 / 6 / 10	10	6	50	51	12A2-20°
125	3 / 6 / 10	14	8	54	54	12A2-20°
150	3 / 6 / 10	16	9	68	68	12A2-20°
175	6 / 10	18	10	82	82	12A2-20°

Form 12A2 | S = 45°

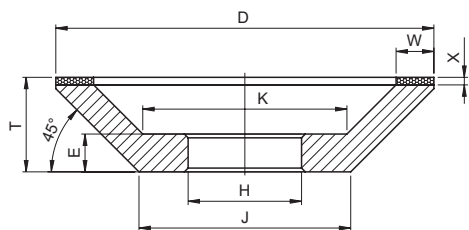

Belagstärke X [mm]: 2, 3 und 4
Bohrung H [mm]: nach Angabe

D [mm]	Abmessungen ¹⁾					
	W [mm]	T-X [mm]	E [mm]	K [mm]	J [mm]	Scheibenform
75	3 / 6 / 10	20	9	37	41	12A2-45°
100	3 / 6 / 10	23	10	54	56	12A2-45°
125	6 / 10 / 15	23	10	79	81	12A2-45°
150	6 / 10 / 15	23	10	94	106	12A2-45°
175	6 / 10 / 15	25	12	123	131	12A2-45°

Bestellbeispiele

■ CBN-Scheibe 4A2
125-6-3-20
B 126 C 100 B8

■ Diamantscheibe 11V9
100-1.5-10-20
D 126 C 75 B

■ CBN-Scheibe 12A2-20°
125-6-4-20
B 91 C 75 B

■ Diamantscheibe 12A2-45°
100-10-4-20
D 91 C 75 B

¹⁾ Weitere Abmessungen auf Anfrage



Werkzeugschleifen mit ► **Diamant**

Anwendungen

Freiflächen
Spanleitstufen

Empfehlung der Zusammensetzung

Belagbreite [mm]	weichere Scheibe	Standard	härtere Scheibe
≤ 3	D 126 C 50 B	D 126 C 75 B	DK 126 C 100 B
4 bis 8	D 126 C 50 B	D 126 C 75 B	DK 126 C 100 B
> 8	D 126 C 50 B	D 126 C 75 B	DK 126 C 100 B

Für Freihandschliff ist die Zusammensetzung DG 126 C 75 M 27 zu empfehlen.

Bei kleiner Kontaktfläche zwischen Scheibe und Werkstück bringt eine harte Scheibe eine gute Standzeit. Entsprechend ist für eine grosse Kontaktfläche eine weichere Scheibe besser. Jede beliebige Zusammensetzung ergibt durch die Wahl einer niedrigeren Konzentration einen weichen Schliff.

Bindung

- B für Trocken- und Nassschliff
- B3A . . . nur für Nassschliff
- M27 . . . für Freihand bis Nassschliff

Weitere Bindungen → [Seite 4-7](#)

Scheibendimension

- Durchmesser D
So gross wie möglich, unter Beachtung der empfohlenen Schnittgeschwindigkeit v.
- Breite W bzw. X
Je breiter der Belag ist, desto weicher sollte die Zusammensetzung gewählt werden. Die Belagbreite muss jedoch unbedingt schmaler sein als die Eintauchtiefe der zu schleifenden Spanfläche (→ [Seite 4-8](#)).

Schnittdaten

- Schnittgeschwindigkeit v
 - Trockenschliff: 10 – 15 m/s
 - Nassschliff: 15 – 20 m/s
- Vorschub s und Zustellung a müssen den Arbeitsbedingungen angepasst werden.

Werkzeugschleifen mit ► **CBN**

Anwendungen

Freiflächen
Spanleitstufen

Empfehlung der Zusammensetzung

Belagbreite [mm]	weichere Scheibe	Standard	härtere Scheibe
≤ 3	B 126 C 50 B	B 126 C 75 B	B 126 C 100 B3
4 bis 8	B 126 C 50 B	B 126 C 75 B8	B 126 C 100 B3
> 8	B 126 C 50 B	B 126 C 75 B8	B 126 C 100 B3

Bei kleiner Kontaktfläche zwischen Scheibe und Werkstück bringt eine harte Scheibe eine gute Standzeit. Entsprechend ist für eine grosse Kontaktfläche eine weichere Scheibe besser. Jede beliebige Zusammensetzung ergibt durch die Wahl einer niedrigeren Konzentration einen weichen Schliff.

Bindung

- B für Trocken- und Nassschliff
- B3 nur für Nassschliff
- B8 nur für Trockenschliff, sehr schleiffreudig

Weitere Bindungen → [Seite 4-7](#)

Scheibendimension

- Durchmesser D
So gross wie möglich, unter Beachtung der empfohlenen Schnittgeschwindigkeit v.
- Breite W bzw. X
Je breiter der Belag ist, desto weicher sollte die Zusammensetzung gewählt werden. Die Belagbreite muss jedoch unbedingt schmaler sein als die Eintauchtiefe der zu schleifenden Spanfläche (→ [Seite 4-8](#)).

Schnittdaten

- Schnittgeschwindigkeit v: 25 – 35 m/s
Hinweis: niedrigere Werte ergeben einen höheren Scheibenverschleiss und eine schlechtere Oberfläche.
- Vorschub s und Zustellung a müssen den Arbeitsbedingungen angepasst werden.



Werkzeugschleifen mit Diamant oder CBN

Form 6A2

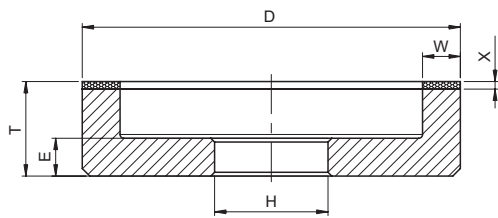

Belagstärke X [mm]: 2, 3, 4 und 6
Bohrung H [mm]: nach Angabe

D [mm]	Abmessungen ¹⁾			Scheibenform
	W [mm]	T-X [mm]	E [mm]	
50	3 / 5	20	10	6A2
75	3 / 5 / 10	20	10	6A2
100	5 / 10 / 12 / 15	23	10	6A2
125	6 / 10 / 12 / 15	23	10	6A2
150	6 / 10 / 12 / 15 / 20 / 25	23	10	6A2
175	6 / 10 / 15 / 20 / 25	25	13	6A2
200	10 / 15 / 20 / 25	25	13	6A2
250	10 / 15 / 20 / 25	25	13	6A2
300	20 / 25	30	15	6A2
350	25	35	18	6A2

Form 9A3

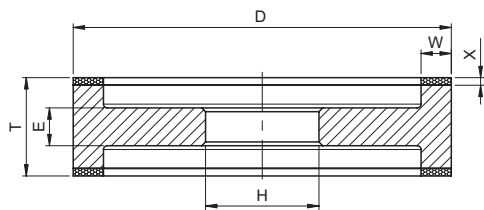

Belagstärke X [mm]: 2, 3 und 4
Bohrung H [mm]: nach Angabe

D [mm]	Abmessungen ¹⁾			Scheibenform
	W [mm]	T-2X [mm]	E [mm]	
100	6 / 8 / 10	22	10	9A3
125	6 / 8 / 10	22	10	9A3
150	6 / 8 / 10 / 12 / 15	25 / 35	14	9A3
175	6 / 8 / 10 / 12 / 15	25 / 35	14	9A3
200	8 / 10 / 12 / 15	30	18	9A3

Form 6A9 – Belag innen abgestützt

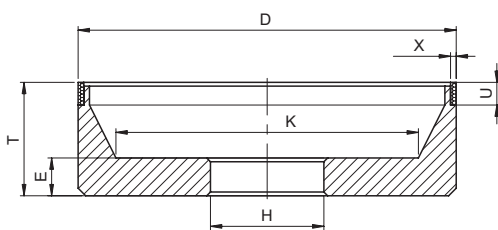

Belagstärke X [mm]: 1.5 und 3
Bohrung H [mm]: nach Angabe

D [mm]	Abmessungen ¹⁾				Scheibenform
	U [mm]	T [mm]	E [mm]	K [mm]	
75	6 / 10	25	10	60	6A9
100	6 / 10	30	10	80	6A9
125	6 / 10	30	10	110	6A9
150	6 / 10	35	10	135	6A9
200	6 / 10	35	13	175	6A9
250	6 / 10	50	20	225	6A9

Form 11A2

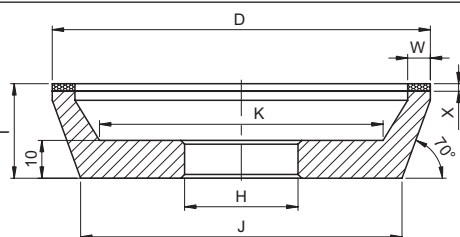

Belagstärke X [mm]: 2, 3 und 4
Bohrung H [mm]: nach Angabe

D [mm]	Abmessungen ¹⁾				Scheibenform
	W [mm]	T-X [mm]	K [mm]	J [mm]	
75	3 / 6 / 10	20	48	63	11A2
100	6 / 10 / 15	23	55	68	11A2
125	6 / 10 / 15	23	98	110	11A2
150	6 / 10 / 15	23	110	135	11A2

Bestellbeispiele

■ **Diamantscheibe 6A2**
150-20-6-40
D 126 C 75 B

■ **Diamantscheibe 9A3**
175-6-4-20
D 126 C 75 B

■ **CBN-Scheibe 6A9**
200-1.5-10-51
B 151 C 100 B3

■ **Diamantscheibe 11A2**
100-10-4-20
D 126 C 75 B

¹⁾ Weitere Abmessungen auf Anfrage



Werkzeugschleifen mit ► **Diamant**

Anwendungen

Spanflächen

Empfehlung der Zusammensetzung

Scheibenform	weichere Scheibe	Standard	härtere Scheibe
4ET9	D 91 C 75 B	D 91 C 100 B	DK 91 C 100 B
4BT9	D 91 C 75 B	D 91 C 100 B	DK 91 C 100 B
12V9	D 126 C 75 B	D 126 C 100 B	DK 126 C 100 B
12V2	D 126 C 75 B	D 126 C 100 B	DK 126 C 100 B

Bindung

■ B für Trocken- und Nassschliff

■ B3A . . . nur für Nassschliff

Weitere Bindungen → [Seite 4-7](#)

Scheibenform

Die Tellerscheiben (4ET9 und 4BT9) sollten eher in einer weicheren Zusammensetzung eingesetzt werden.

Scheibendimension

■ Durchmesser D

So gross wie möglich, unter Beachtung der empfohlenen Schnittgeschwindigkeit v.

■ Breite W bzw. X

Je breiter der Belag ist, desto weicher sollte die Zusammensetzung gewählt werden. Die Belagbreite muss jedoch unbedingt schmaler sein als die Eintauchtiefe der zu schleifenden Spanfläche (→ [Seite 4-8](#)).

Schnittdaten

■ Schnittgeschwindigkeit v

■ Trockenschliff: 10 – 15 m/s

■ Nassschliff: 15 – 20 m/s

■ Vorschub s und Zustellung a müssen den Arbeitsbedingungen angepasst werden.

Werkzeugschleifen mit ► **CBN**

Anwendungen

Spanflächen

Empfehlung der Zusammensetzung

Scheibenform	weichere Scheibe	Standard	härtere Scheibe
4ET9	B 126 C 50 B	B 126 C 75 B	B 126 C 100 B
4BT9	B 126 C 50 B	B 126 C 75 B	B 126 C 100 B
12V9	B 126 C 50 B8	B 126 C 75 B8	B 126 C 100 B8
12V2	B 126 C 75 B	B 126 C 75 B	B 126 C 100 B

Bindung

■ B für Trocken- und Nassschliff

■ B3 nur für Nassschliff

■ B8 nur für Trockenschliff, sehr schleiffreudig

Weitere Bindungen → [Seite 4-7](#)

Scheibenform

Die Tellerscheiben (4ET9 und 4BT9) sollten eher in einer weicheren Zusammensetzung eingesetzt werden.

Scheibendimension

■ Durchmesser D

So gross wie möglich, unter Beachtung der empfohlenen Schnittgeschwindigkeit v.

■ Breite W bzw. X

Je breiter der Belag ist, desto weicher sollte die Zusammensetzung gewählt werden. Die Belagbreite muss jedoch unbedingt schmaler sein als die Eintauchtiefe der zu schleifenden Spanfläche (→ [Seite 4-8](#)).

Schnittdaten

■ Schnittgeschwindigkeit v: 25 – 35 m/s

Hinweis: niedrigere Werte ergeben einen höheren Scheibenverschleiss und eine schlechtere Oberfläche.

■ Vorschub s und Zustellung a müssen den Arbeitsbedingungen angepasst werden.



Werkzeugschleifen mit Diamant oder CBN

Form 4BT9

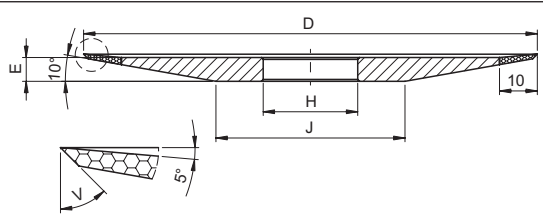

Bohrung H [mm]: nach Angabe
Winkel V: nach Angabe

D [mm]	Abmessungen ¹⁾			Scheibenform
	E [mm]	J [mm]		
75	8	37		4BT9
100	10	50		4BT9
125	12	65		4BT9

Form 4ET9

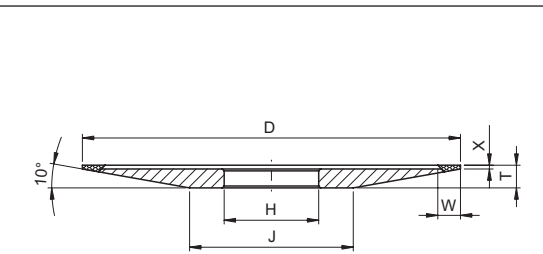

Bohrung H [mm]: nach Angabe

D [mm]	Abmessungen ¹⁾					Scheibenform
	W [mm]	X [mm]	T [mm]	J [mm]		
50	4 / 6	1	6	25	4ET9	
75	4 / 6	1	6	30	4ET9	
100	4 / 6	1	6	43	4ET9	
125	6 / 10	2	8	57	4ET9	
150	6 / 10	2	10	59	4ET9	
175	6 / 10	2	12	62	4ET9	

Form 12V2

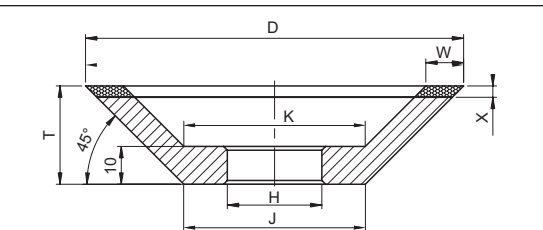

Belagstärke X [mm]: 2, 3 und 4
Bohrung H [mm]: nach Angabe

D [mm]	Abmessungen ¹⁾					Scheibenform
	W [mm]	T-X [mm]	K [mm]	J [mm]		
75	5	20	27	45	12V2	
100	5 / 8 / 10	23	48	48	12V2	
125	5 / 8 / 10	23	68	73	12V2	
150	8 / 10	23	82	98	12V2	

Form 12V9

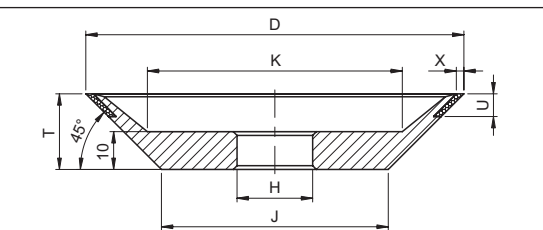

Belagstärke X [mm]: 1.5, 2 und 3
Bohrung H [mm]: nach Angabe

D [mm]	Abmessungen ¹⁾					Scheibenform
	U [mm]	T [mm]	K [mm]	J [mm]		
75	6 / 10	20	45	35	12V9	
100	6 / 10	20	65	60	12V9	
125	6 / 10	25	80	75	12V9	
150	6 / 10	25	105	105	12V9	

Bestellbeispiele

■ **Diamantscheibe 4BT9**
100-10-1-20
D 91 C 100 B

■ **Diamantscheibe 4ET9**
150-10-2-20
D 91 C 100 B

■ **Diamantscheibe 12V2**
125-8-4-20
D 126 C 100 B

■ **CBN-Scheibe 12V9**
100-1.5-10-20
D 126 C 100 B

¹⁾ Weitere Abmessungen auf Anfrage



Flatschleifen mit ► **Diamant**

Empfehlung der Zusammensetzung

Belagbreite [mm]	weichere Scheibe	Standard	härtere Scheibe
≤ 3	D 126 C 75 B3A	DN 126 C 75 B3A	DN 126 C 100 B6
4 bis 8	D 126 C 75 B3A	DN 126 C 75 B3A	DN 126 C 100 B3A
> 8	D 126 C 75 B	DN 126 C 75 B	DN 126 C 75 B3A

Bindung

- B3A . . . nur für Nassschliff
 - B für Trocken- und Nassschliff
- Weitere Bindungen → [Seite 4-7](#)

Scheibenform

Bei wärmeempfindlichen Werkstoffen empfiehlt sich Form 6A9.

Aufgrund der grösseren Belagbreite von Form 6A2 ist die Kühlmittelzufuhr zwischen Scheibe und Werkstück häufig unzureichend.

Bei hohen Anforderungen an die Oberflächengüte oder bei ungenügender Maschinenstabilität ist Form 6A2 von Vorteil.

Scheibendimension

- Durchmesser D
So gross wie möglich, unter Beachtung der empfohlenen Schnittgeschwindigkeit v.
- Belagbreite
Die Belagbreite bei 6A2 = W so schmal wie möglich und bei 6A9 = U so breit wie möglich.

Schnittdaten

- Schnittgeschwindigkeit v
 - Trockenschliff: 10 – 12 m/s
 - Nassschliff: 12 – 15 m/s
- Vorschub s und Zustellung a müssen den Arbeitsbedingungen angepasst werden.

Flatschleifen mit ► **CBN**

Empfehlung der Zusammensetzung

Belagbreite [mm]	weichere Scheibe	Standard	härtere Scheibe
≤ 3	B 126 C 75 B	B 126 C 75 B3	B 126 C 100 B6
4 bis 8	B 126 C 50 B	B 126 C 75 B3	B 126 C 100 B6
> 8	B 126 C 75 B8	B 126 C 75 B3	B 126 C 75 B6

Bindung

- B8 nur für Trockenschliff, sehr schleiffreudig
 - B für Trocken- und Nassschliff
 - B3 und B6 . . nur für Nassschliff
- Weitere Bindungen → [Seite 4-7](#)

Scheibenform

Bei wärmeempfindlichen Werkstoffen empfiehlt sich Form 6A9.

Auf Grund der grösseren Belagbreite von Form 6A2 ist die Kühlmittelzufuhr zwischen Scheibe und Werkstück häufig unzureichend.

Bei hohen Anforderungen an die Oberflächengüte oder bei ungenügender Maschinenstabilität ist Form 6A2 von Vorteil.

Scheibendimension

- Durchmesser D
So gross wie möglich, unter Beachtung der empfohlenen Schnittgeschwindigkeit v.
- Belagbreite
Die Belagbreite bei 6A2 = W so schmal wie möglich und bei 6A9 = U so breit wie möglich.

Schnittdaten

- Schnittgeschwindigkeit v
 - Trockenschliff: 20 – 30 m/s
 - Nassschliff: 25 – 40 m/s
- Schnittgeschwindigkeit v: mindestens 25 m/s
Eine grössere Schnittgeschwindigkeit erhöht die Standzeit der Scheibe. Wenn eine gute Kühlung gegeben ist, kann mit Schnittgeschwindigkeiten bis 100 m/s gefahren werden.
- Vorschub s und Zustellung a müssen den Arbeitsbedingungen angepasst werden.



Flachscheifen mit Diamant oder CBN

Form 6A2

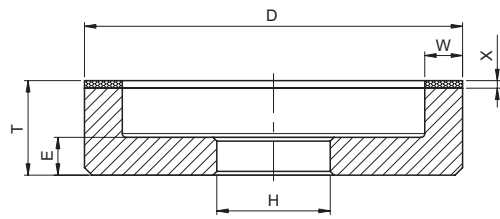

Belagstärke X [mm]: 2, 3, 4 und 6
 Bohrung H [mm]: nach Angabe
 Scheiben-Ø D <175 mm → Form 6A2 für Werkzeugschleifen

D [mm]	Abmessungen ¹⁾			E [mm]	Scheibenform
	W [mm]	T-X [mm]			
175	6 / 10 / 15 / 20 / 25	25		13	6A2
200	10 / 15 / 20 / 25	25		13	6A2
250	10 / 15 / 20 / 25	25		13	6A2
300	20 / 25	30		15	6A2
350	25	35		18	6A2

Form 6A9 – Belag innen abgestützt

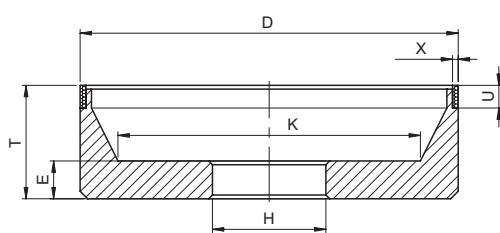

Belagstärke X [mm]: 1.5, und 3
 Bohrung H [mm]: nach Angabe

D [mm]	Abmessungen ¹⁾				Scheibenform
	U [mm]	T [mm]	E [mm]	K [mm]	
75	6 / 10	25	10	60	6A9
100	6 / 10	30	10	80	6A9
125	6 / 10	30	10	110	6A9
150	6 / 10	35	10	135	6A9
200	6 / 10	35	13	175	6A9
250	6 / 10	50	20	225	6A9

Bestellbeispiele

- **Diamantscheibe 6A2**
250-20-6-51
D 126 C 75 B3
- **CBN-Scheibe 6A9**
200-1.5-10-51
B 151 C 100 B3

¹⁾ Weitere Abmessungen auf Anfrage



Flachschleifen mit ► **Diamant**

Empfehlung der Zusammensetzung

Scheiben- durchmesser D [mm]	weichere Scheibe	Standard	härtere Scheibe
bis 250	D 126 C 75 B	D 126 C 75 B2A	DN 126 C 100 B2A
250 bis 500	D 126 C 75 B2A	DN 126 C 75 B2A	DN 126 C 100 B2A

Bindung

- B für Trocken- und Nassschliff
- B2A . . . nur für Nassschliff

Weitere Bindungen → [Seite 4-7](#)

Scheibendimension

- Durchmesser D
So gross wie möglich, unter Beachtung der empfohlenen Schnittgeschwindigkeit v.
- Breite T
So gross wie möglich, jedoch Leistung und Stabilität der Maschine berücksichtigen.

Schnittdaten

- Schnittgeschwindigkeit v
 - Trockenschliff: 10 – 15 m/s
 - Nassschliff: 20 m/s
- Tischvorschub u: 6 – 8 m/min
- Quervorschub s: 1/3 – 2/3 der Scheibenbreite pro Hub
- Zustellung a: 0.01 mm pro Querhub

Weitere Kombinationen von Vorschub und Zustellung, welche das gleiche Spanvolumen ergeben, können auch angewendet werden.

Flachschleifen mit ► **CBN**

Empfehlung der Zusammensetzung

Scheiben- durchmesser D [mm]	weichere Scheibe	Standard	härtere Scheibe
bis 250	B 126 C 75 B	B 126 C 75 B3A	B 126 C 100 B3
250 bis 500	B 126 C 50 B	B 126 C 50 B3	B 126 C 75 B3

Bindung

- B für Trocken- und Nassschliff
- B3 nur für Nassschliff

Weitere Bindungen → [Seite 4-7](#)

Das verwendete Kühlmittel sollte eine 5- bis 10-prozentige Emulsion eines HD-Konzentrates sein.

Scheibendimension

- Durchmesser D
So gross wie möglich, unter Beachtung der empfohlenen Schnittgeschwindigkeit v.
- Breite T
So gross wie möglich, jedoch Leistung und Stabilität der Maschine berücksichtigen.

Schnittdaten

- Schnittgeschwindigkeit v
 - Trockenschliff: 20 – 25 m/s
 - Nassschliff: 35 m/s (mind. 25 m/s)
Eine grössere Schnittgeschwindigkeit erhöht die Standzeit der Scheibe. Wenn eine gute Kühlung gegeben ist, kann mit Schnittgeschwindigkeit bis 100 m/s gefahren werden.
- Tischvorschub u: 20 – 30 m/min
- Quervorschub s: 1/3 – 2/3 der Scheibenbreite pro Hub
- Zustellung a: 0.01 mm pro Querhub

Weitere Kombinationen von Vorschub und Zustellung, welche das gleiche Spanvolumen ergeben, können auch angewendet werden.



Flachscheifen mit Diamant oder CBN

Form 1A1

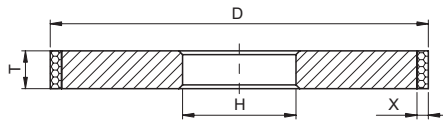

Belagstärke X [mm]: 2, 3 und 6
 Bohrung H [mm]: nach Angabe
 Scheiben-Ø D <100 mm → Form 1A1 für Innenschleifen

D [mm]	Abmessungen ¹⁾		Scheibenform
	T [mm]		
100	4 / 5 / 6 / 8 / 10 / 12 / 15		1A1
125	4 / 5 / 6 / 8 / 10 / 12 / 15		1A1
150	4 / 5 / 6 / 8 / 10 / 12 / 15		1A1
175	6 / 10 / 12 / 15 / 20		1A1
200	6 / 10 / 12 / 15 / 20		1A1
225	12 / 15 / 20 / 25		1A1
250	6 / 10 / 12 / 15 / 20 / 25 / 30 / 40 / 60		1A1
300	10 / 12 / 15 / 20 / 40 / 60		1A1
350	12 / 15 / 20 / 40 / 60 / 100		1A1
400	12 / 15 / 20 / 40 / 60 / 100		1A1
500	12 / 15 / 20 / 40 / 60 / 100		1A1
600	12 / 15 / 20 / 40 / 60 / 100		1A1

Form 14A1

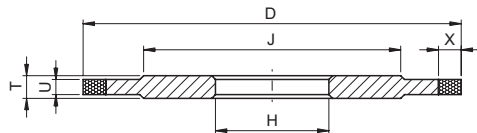

Belagstärke X [mm]: 2, 3 und 6
 Bohrung H [mm]: nach Angabe

D [mm]	Abmessungen ¹⁾			Scheibenform
	U [mm]	T [mm]	J [mm]	
75	1 / 2 / 3	6	50	14A1
100	1 / 2 / 3	6	70	14A1
125	1 / 2 / 3	6	100	14A1
150	1 / 2 / 3	10	120	14A1
175	3 / 6	10	140	14A1
200	3 / 6	12	160	14A1
250	6 / 10	15	200	14A1
300	6 / 10	15	250	14A1
350	6 / 10	15	300	14A1
400	6 / 10 / 15	20	350	14A1
500	10 / 15	20	400	14A1
600	10 / 15	20	500	14A1

Bestellbeispiele

■ **Diamantscheibe 1A1**
 300-20-4-127
 D 126 C 75 B2A

■ **Diamantscheibe 14A1**
 200-3-6-51
 D 126 C 100 B2A

¹⁾ Weitere Abmessungen auf Anfrage



Profilschleifen mit ► **Diamant**

Empfehlung der Zusammensetzung

Scheibenform	Profiltiefe (P) Radius (R) [mm]	Trockenschliff	Nassschliff Tiefschliff
14V1/14EE1	$P \leq 5$	DK 107 C 125 B	DG 126 C 125 M27
14V1/14EE1	$P > 5$	DK 126 C 100 B	DM 126 C 100 B6
1FF1/14F1	$R \leq 5$	DK 107 C 125 B	DG 126 C 125 M27
1FF1/14F1	$R > 5$	DK 126 C 100 B	DM 126 C 100 B6

Wenn bei Scheiben vom Form 14V1 und 14EE1 ein Spitzenradius < 0.5 mm erforderlich ist, empfiehlt sich eine feinere Körnung oder eine höhere Konzentration.

Bindung

- M27 und B6. . . nur für Nassschliff
- B für Trocken- und Nassschliff

Weitere Bindungen → [Seite 4-7](#)

Scheibendimension

- Durchmesser D
So gross wie möglich, unter Beachtung der empfohlenen Schnittgeschwindigkeit v. Beim Tiefschleifen kann die Kühlung problematisch werden, insbesondere bei wärmeempfindlichen Werkstoffen. Hier sollte der Durchmesser D oder Schnittgeschwindigkeit v reduziert werden..

Schnittdaten

- Schnittgeschwindigkeit v
 - Trockenschliff: 10 – 12 m/s
 - Nassschliff/Tiefschliff: 12 – 15 m/s
- Umfangsgeschwindigkeit des Werkstücks uw
 - Normalschliff: 15 – 20 m/min
 - Tiefschliff: 0.5 – 1 m/min

Profilschleifen mit ► **CBN**

Empfehlung der Zusammensetzung

Scheibenform	Profiltiefe (P) Radius (R) [mm]	Trockenschliff	Nassschliff Tiefschliff
14V1/14EE1	$P \leq 5$	B 107 C 100 B	BM 107 C 100 M27
14V1/14EE1	$P > 5$	B 126 C 100 B8	B 126 C 100 B6
1FF1/14F1	$R \leq 5$	B 107 C 100 B	BM 107 C 100 M27
1FF1/14F1	$R > 5$	B 126 C 100 B8	B 126 C 100 B6

Wenn bei Scheiben vom Form 14V1 und 14EE1 ein Spitzenradius < 0.5 mm erforderlich ist, empfiehlt sich eine feinere Körnung oder eine höhere Konzentration.

Bindung

- B für Trocken- und Nassschliff
- B8 nur für Trockenschliff, sehr schleiffreudig
- M27 und B6. . . nur für Nassschliff

Weitere Bindungen → [Seite 4-7](#)

Das verwendete Kühlmittel sollte eine 5- bis 10-prozentige Emulsion eines HD- Konzentrates sein. Wesentlich besser ist Schneidöl.

Scheibendimension

- Durchmesser D
So gross wie möglich, unter Beachtung der empfohlenen Schnittgeschwindigkeit v. Beim Tiefschleifen kann die Kühlung problematisch werden, insbesondere bei wärmeempfindlichen Werkstoffen. Hier sollte der Durchmesser D oder die Schnittgeschwindigkeit v reduziert werden.

Schnittdaten

- Schnittgeschwindigkeit v
 - Trockenschliff: 20 – 30 m/s
 - Nassschliff/Tiefschliff: 25 – 40 m/s
- Umfangsgeschwindigkeit der Werkstücks uw
 - Normalschliff: 25 – 30 m/min
 - Tiefschliff: 0.5 – 1 m/min



Profilschleifen mit Diamant oder CBN

Form 1FF1

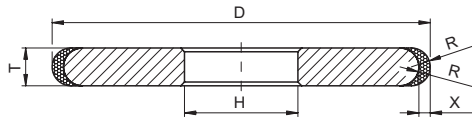

Belagstärke X [mm]: 2, 3 und 4
Bohrung H [mm]: nach Angabe
Scheibenbreite T [mm]: min. 4, max. 20
Radius R [mm]: min. 2, max. 10

Abmessung ¹⁾		Scheibenform
D	D [mm]	
	50	1FF1
	75	1FF1
	100	1FF1
	125	1FF1
	150	1FF1

Form 14V1

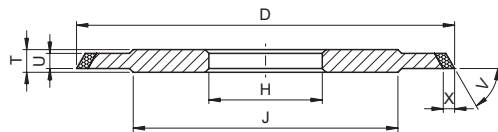

Belagstärke X [mm]: 2, 3 und 4
Bohrung H [mm]: nach Angabe
Winkel V: nach Angabe (zwischen 30° und 89°)

Abmessungen ¹⁾					Scheibenform
D [mm]	U [mm]	T [mm]	J [mm]		
75	4 / 6 ²⁾ / 8 ²⁾ / 10 ²⁾	6	50		14V1
100	4 / 6 ²⁾ / 8 ²⁾ / 10 ²⁾	6	70		14V1
125	6 / 8 ²⁾ / 10 ²⁾ / 15 ²⁾	8	100		14V1
150	6 / 8 ²⁾ / 10 ²⁾ / 15 ²⁾	8	120		14V1
175	6 / 8 / 10 ²⁾ / 15 ²⁾ / 20 ²⁾	10	140		14V1
200	6 / 8 / 10 / 12 ²⁾ / 15 ²⁾ / 20 ²⁾	12	160		14V1
250	15 ²⁾ / 20 ²⁾	15	180		14V1

²⁾ Ohne Verstärkung des Scheibenkörpers Form 1V1, in diesem Fall ist U = T

Form 14EE1

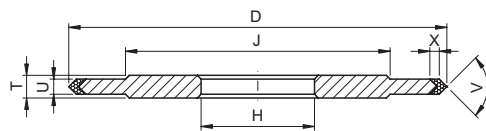

Belagstärke X [mm]: 2.5 und 5 bei V 45°
2 und 4 bei V 60°
1.5 und 3 bei V 90°
Bohrung H [mm]: nach Angabe

Abmessungen ¹⁾					Scheibenform
D [mm]	U [mm]	V	T [mm]	J [mm]	
50	3	45° / 60° / 90°	3	–	14EE1
75	3	45° / 60° / 90°	3	–	14EE1
100	3 / 4	45° / 60° / 90°	6	70	14EE1
125	3 / 4	45° / 60° / 90°	6	100	14EE1
150	3 / 4	45° / 60° / 90°	6	120	14EE1
175	4 / 5	45° / 60° / 90°	8	140	14EE1
200	4 / 5	45° / 60° / 90°	10	160	14EE1
250	4 / 5	45° / 60° / 90°	15	200	14EE1

Form 14F1

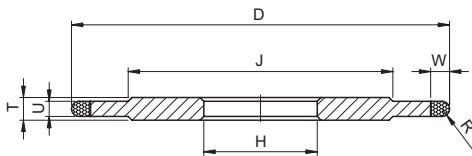

Bohrung H [mm]: nach Angabe

Abmessungen ¹⁾					Scheibenform
D [mm]	U [mm]	R [mm]	T [mm]	J [mm]	
50	2 / 3 / 4	1 / 1.5 / 2	6	30	14F1
75	2 / 3 / 4	1 / 1.5 / 2	6	50	14F1
100	2 / 3 / 4	1 / 1.5 / 2	6	70	14F1
125	2 / 3 / 4	1 / 1.5 / 2	8	100	14F1
150	2 / 3 / 4	1 / 1.5 / 2	8	120	14F1

Bestellbeispiele

■ **Diamantscheibe 1FF1**
100-10-R5-3-20
DK 126 C 100 B2

■ **Diamantscheibe 1V1/14V1**
175-10-3-V60°-32
DK 126 C 100 B2

■ **Diamantscheibe 14EE1**
150-4-4-V60°-20
D 126 C 100 B2

■ **CBN-Scheibe 14F1**
125-4-R2-5-20
B 151 C 125 B6

¹⁾ Weitere Abmessungen auf Anfrage



Innenschleifen mit **Diamant**

Empfehlung der Zusammensetzung

Scheibendurchmesser D [mm]	weichere Scheibe	Standard	härtere Scheibe
≤ 50	D 126 C 75 B	D 126 C 100 B2A	DN 126 C 100 B2A
50 bis 100	D 126 C 75 B	DN 126 C 75 B2A	DN 126 C 100 B2A

Bindung

- B für Trocken- und Nassschliff (Trockenschliff möglichst vermeiden)
- B2A . . . nur für Nassschliff

Weitere Bindungen → [Seite 4-7](#)

Scheibendimension

- Durchmesser D
So gross wie möglich bis Bohrungsdurchmesser 40 mm. Bei grösseren Bohrungen soll der Scheibendurchmesser ca. 75 % des Bohrungsdurchmessers betragen.
- Breite T
Eine grössere Scheibenbreite ergibt im Allgemeinen eine bessere Oberfläche, jedoch auch einen höheren Schleifdruck. Daher Schleifspindeldimension berücksichtigen.

Schnittdaten

- Schnittgeschwindigkeit v: 12 – 16 m/s
- Umfangsgeschwindigkeit des Werkstücks uw: 20 – 30 m/min
- Vorschub s: 1/4 – 3/4 der Scheibenbreite pro Werkstückumdrehung.

Kühlung

Durch die relativ grosse Kontaktfläche zwischen Scheibe und Bohrungswand entsteht beim Innenschleifen viel Wärme, die durch eine effektive Kühlung abgeleitet werden soll.

Innenschleifen mit **CBN**

Empfehlung der Zusammensetzung

Scheibendurchmesser D [mm]	weichere Scheibe	Standard	härtere Scheibe
bis 100	B 126 C 75 B3	B126 C 100 B3	B 126 C 100 B6

Zum Schleifen gehärteter Konstruktionsstähle, z. B. Kugellagerstahl, können auch keramisch gebundene CBN-Scheiben eingesetzt werden. Für Bohrung ≤ Ø40 mm empfehlen wir B 151 C 150 V.

Bindung

- B3 und B6 . . nur für Nassschliff

Weitere Bindungen → [Seite 4-7](#)

Scheibendimension

- Durchmesser D
So gross wie möglich bis Bohrungsdurchmesser 40 mm. Bei grösseren Bohrungen soll der Scheibendurchmesser ca. 75 % des Bohrungsdurchmessers betragen.
- Breite T
Eine grössere Scheibenbreite ergibt im Allgemeinen eine bessere Oberfläche, jedoch auch einen höheren Schleifdruck. Daher Schleifspindeldimension berücksichtigen.

Schnittdaten

- Schnittgeschwindigkeit v: mindestens 25 m/s
Eine grössere Schnittgeschwindigkeit erhöht die Standzeit der Scheibe. Wenn eine gute Kühlung gegeben ist, kann mit Schnittgeschwindigkeit bis 100 m/s gefahren werden.
- Umfangsgeschwindigkeit des Werkstücks uw: 20 m/min – 30 m/min
- Vorschub s: 1/4 – 3/4 der Scheibenbreite pro Werkstückumdrehung.

Kühlung

Durch die relativ grosse Kontaktfläche zwischen Scheibe und Bohrungswand entsteht beim Innenschleifen viel Wärme, die durch eine effektive Kühlung abgeleitet werden soll.



Innenschleifen mit Diamant oder CBN

Form 1A1

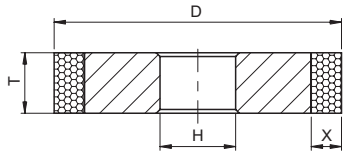

Belagstärke X [mm]: 2, 3, 4 und 6
 Bohrung H [mm]: nach Angabe
 Scheiben-Ø D >75 mm → Form 1A1 für Aussen-
 rundscheifen

D [mm]	Abmessungen ¹⁾		Scheibenform
	T [mm]		
20	4 / 6 / 8 / 10 / 12		1A1
25	4 / 6 / 8 / 10 / 12		1A1
30	4 / 6 / 8 / 10 / 12		1A1
40	4 / 6 / 8 / 10 / 12		1A1
50	4 / 6 / 8 / 10 / 12		1A1
75	3 / 4 / 5 / 6 / 8 / 10 / 12		1A1

Bestellbeispiele

■ CBN-Scheibe 1A1
 40-10-3-12
 B 151 C 100 B3

¹⁾ Weitere Abmessungen auf Anfrage



Schleifstifte mit ► **Diamant**

Empfehlung der Zusammensetzung

Bindung	Standard
Kunststoff	D 126 C 100 B2A
Metall	DG 126 C 100 M27
galvanisch	D 126

Scheibendimension

- Durchmesser D
So gross wie möglich bis Bohrungsdurchmesser 40 mm. Bei grösseren Bohrungen soll der Scheibendurchmesser ca. 75 % des Bohrungsdurchmessers betragen.
- Breite T
Eine grössere Scheibenbreite ergibt im Allgemeinen eine bessere Oberfläche, jedoch auch einen höheren Schleifdruck. Daher Schleifspindeldimension berücksichtigen.

Schnittdaten

- Schnittgeschwindigkeit v
 - Allgemein: 12 – 16 m/s
 - Galvanisch: 10 – 24 m/s
- Umfangsgeschwindigkeit des Werkstücks uw:
20 – 30 m/min
- Vorschub s: 1/4 – 3/4 der Scheibenbreite pro Werkstückumdrehung.

Kühlung

Durch die relativ grosse Kontaktfläche zwischen Scheibe und Bohrungswand entsteht beim Innenschleifen viel Wärme, die durch eine effektive Kühlung abgeleitet werden soll. Ein Trockenschliff sollte möglichst vermieden werden.

Schleifstifte mit ► **CBN**

Empfehlung der Zusammensetzung

Bindung	Standard
Kunststoff	D 126 C 100 B
Metall	BM 126 C 100 M27
galvanisch	B 151

Scheibendimension

- Durchmesser D
So gross wie möglich bis Bohrungsdurchmesser 40 mm. Bei grösseren Bohrungen soll der Scheibendurchmesser ca. 75 % des Bohrungsdurchmessers betragen.
- Breite T
Eine grössere Scheibenbreite ergibt im Allgemeinen eine bessere Oberfläche, jedoch auch einen höheren Schleifdruck. Daher Schleifspindeldimension berücksichtigen.

Schnittdaten

- Schnittgeschwindigkeit v
 - Allgemein: mind. 25 m/s
 - Galvanisch: 10 – 24 m/s
- Umfangsgeschwindigkeit des Werkstücks uw:
20 – 30 m/min
- Vorschub s: 1/4 – 3/4 der Scheibenbreite pro Werkstückumdrehung.

Kühlung

Durch die relativ grosse Kontaktfläche zwischen Scheibe und Bohrungswand entsteht beim Innenschleifen viel Wärme, die durch eine effektive Kühlung abgeleitet werden soll. Ein Trockenschliff sollte möglichst vermieden werden.



Schleifstifte mit Diamant oder CBN

Form 1A1W – Schleifstifte in Kunststoff- und Metallbindung

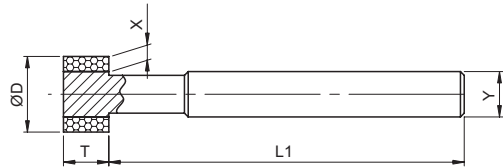

ØD [mm]	Abmessungen ¹⁾				Scheibenform
	T [mm]	X [mm]	L ₁ [mm]	Y [mm]	
3	6	0.75	60	3	1A1W
4	6	1	60	3	1A1W
5	6	1.5	60	3	1A1W
6	6 / 8	1.5	60	6	1A1W
7	6	2	60	6	1A1W
8	6 / 10	2	60	6	1A1W
9	6	2	60	6	1A1W
10	6 / 10	2	60	6	1A1W
12	6 / 10	2	60	6	1A1W
15	6 / 10	2	60	6	1A1W
18	6 / 10	2	60	6	1A1W
20	6 / 10	2	60	6	1A1W

Form 1A1W – Schleifstifte in galvanischer Bindung

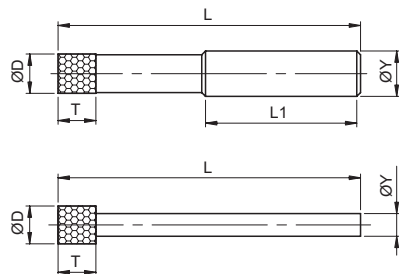

ØD [mm]	T [mm]	L [mm]	Abmessungen ¹⁾		Korngrösse	Scheibenform
			L ₁ [mm]	ØY [mm]		
0.5	2	40	33	3	B/D 91	1A1W
0.6	3	40	33	3	B/D 91	1A1W
0.7	3	40	33	3	B/D 91	1A1W
0.8	3	40	31	3	B/D 91 und 126	1A1W
0.9	3	40	31	3	B/D 91 und 126	1A1W
1.0	3	40	27	3	B/D 91 / 126 und 151	1A1W
1.2	3	40	27	3	B/D 91 / 126 und 151	1A1W
1.5	3	40	27	3	B/D 91 / 126 und 151	1A1W
1.7	4	40	27	3	B/D 91 / 126 und 151	1A1W
2.0	5	40	27	3	B/D 91 / 126 und 151	1A1W
2.5	5	40	27	3	B/D 91 / 126 und 151	1A1W
3.0	5	40	27	3	B/D 91 / 126 und 151	1A1W
3.5	5	40	–	3	B/D 91 / 126 und 151	1A1W
4.0	5	40	–	3	B/D 91 / 126 und 151	1A1W
4.5	5	40	–	3	B/D 91 / 126 und 151	1A1W
5.0	6	40	–	3	B/D 91 / 126 und 151	1A1W
6.0	10	60	40	6	B/D 91 / 126 und 151	1A1W
7.0	10	60	–	6	B/D 91 / 126 und 151	1A1W
8.0	10	80	–	6	B/D 91 / 126 und 151	1A1W
10.0	10	80	–	6	B/D 91 / 126 und 151	1A1W
12.0	15	80	–	6	B/D 91 / 126 und 151	1A1W
15.0	15	80	–	6	B/D 91 / 126 und 151	1A1W
16.0	15	80	–	6	B/D 91 / 126 und 151	1A1W
18.0	15	80	–	6	B/D 91 / 126 und 151	1A1W
20.0	15	80	–	8	B/D 91 / 126 und 151	1A1W

Bestellbeispiele

■ **Diamant-Schleifstift 1A1W**
10–10–2
D 126 C 100 B2A

■ **Diamant-Schleifstift 1A1W**
6–7
D 126 galvanische Bindung

Hinweis:
Schleifstifte sind auch mit Hartmetallschaft lieferbar.
Preis und Lieferzeit bitte anfragen.

¹⁾ Weitere Abmessungen auf Anfrage



Aussenrundscheifen mit ► **Diamant**

Empfehlung der Zusammensetzung

Scheiben- durchmesser D [mm]	weichere Scheibe	Standard	härtere Scheibe
bis 200	D 126 C 75 B	D 126 C 100 B2A	DN 126 C 100 B2A
200 bis 600	D 126 C 75 B2A	DN 126 C 75 B2A	DN 126 C 100 B2A

Bindung

- B für Trocken- und Nassschliff
- B2A . . . nur für Nassschliff

Weitere Bindungen → [Seite 4-7](#)

Scheibendimension

- Durchmesser D
So gross wie möglich, unter Beachtung der empfohlenen Schnittgeschwindigkeit v.
- Breite T
So gross wie möglich, jedoch Leistung und Stabilität der Maschine berücksichtigen.

Schnittdaten

- Schnittgeschwindigkeit v
 - Trockenschliff: 10 – 15 m/s
 - Nassschliff: 20 m/s
- Umfangsgeschwindigkeit des Werkstücks uw:
15 – 20 m/min
- Vorschub s: 1/3 – 2/3 der Scheibenbreite pro Werkstück-umdrehung.
- Zustellung a: 0.005 – 0.02 mm pro Hub.

Aussenrundscheifen mit ► **CBN**

Empfehlung der Zusammensetzung

Scheiben- durchmesser D [mm]	weichere Scheibe	Standard	härtere Scheibe
bis 200	B 126 C 75 B	B 126 C 75 B3	B 126 C 100 B3
200 bis 600	B 126 C 50 B	B 126 C 50 B3	B 126 C 75 B3

Bindung

- B für Trocken- und Nassschliff
- B3 nur für Nassschliff

Weitere Bindungen → [Seite 4-7](#)

Das verwendete Kühlmittel sollte eine 5- bis 10-prozentige Emulsion eines HD-Konzentrates sein.

Scheibendimension

- Durchmesser D
So gross wie möglich, unter Beachtung der empfohlenen Schnittgeschwindigkeit v.
- Breite T
So gross wie möglich, jedoch Leistung und Stabilität der Maschine berücksichtigen.

Schnittdaten

- Schnittgeschwindigkeit v
 - Trockenschliff: 20 – 30 m/s
 - Nassschliff: 25 – 40 m/s (mind. 25 m/s)
Eine grössere Schnittgeschwindigkeit erhöht die Standzeit der Scheibe. Wenn eine gute Kühlung gegeben ist, kann mit Schnittgeschwindigkeit bis 100 m/s gefahren werden.
- Umfangsgeschwindigkeit des Werkstücks uw:
25 – 30 m/min
- Vorschub: 1/3 – 2/3 der Scheibenbreite pro Werkstück-umdrehung.
- Zustellung a: 0.005 – 0.02 mm pro Hub



Aussenrundscheifen mit Diamant oder CBN

Form 1A1

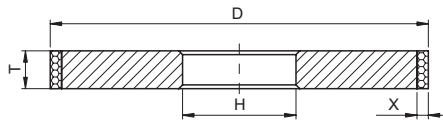

Belagstärke X [mm]: 2, 3 und 6
 Bohrung H [mm]: nach Angabe
 Scheiben-Ø D <100 mm → Form 1A1 für Innenschleifen

D [mm]	Abmessungen ¹⁾		Scheibenform
	T [mm]		
100	4 / 5 / 6 / 8 / 10 / 12 / 15		1A1
125	4 / 5 / 6 / 8 / 10 / 12 / 15		1A1
150	4 / 5 / 6 / 8 / 10 / 12 / 15		1A1
175	6 / 10 / 12 / 15 / 20		1A1
200	6 / 10 / 12 / 15 / 20		1A1
225	12 / 15 / 20 / 25		1A1
250	6 / 10 / 12 / 15 / 20 / 25 / 30 / 40 / 60		1A1
300	10 / 12 / 15 / 20 / 40 / 60		1A1
350	12 / 15 / 20 / 40 / 60 / 100		1A1
400	12 / 15 / 20 / 40 / 60 / 100		1A1
500	12 / 15 / 20 / 40 / 60 / 100		1A1
600	12 / 15 / 20 / 40 / 60 / 100		1A1

Form 14A1

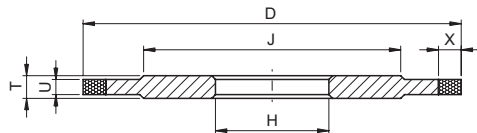

Belagstärke X [mm]: 2, 3 und 6
 Bohrung H [mm]: nach Angabe

D [mm]	Abmessungen ¹⁾			Scheibenform
	U [mm]	T [mm]	J [mm]	
75	1 / 2 / 3	6	50	14A1
100	1 / 2 / 3	6	70	14A1
125	1 / 2 / 3	6	100	14A1
150	1 / 2 / 3	10	120	14A1
175	3 / 6	10	140	14A1
200	3 / 6	12	160	14A1
250	6 / 10	15	200	14A1
300	6 / 10	15	250	14A1
350	6 / 10	15	300	14A1
400	6 / 10 / 15	20	350	14A1
500	10 / 15	20	400	14A1
600	10 / 15	20	500	14A1

Bestellbeispiele

■ **Diamantscheibe 1A1**
 300-20-4-127
 D 126 C 75 B2A

■ **Diamantscheibe 14A1**
 200-3-6-51
 D 126 C 100 B2A

¹⁾ Weitere Abmessungen auf Anfrage



Trennschleifen mit **Diamant**

Empfehlung der Zusammensetzung

Kontaktfläche	Trockenschliff	Nassschliff
klein	D 107 C 100 B	D 107 C 100 B4
gross	–	D 107 C 100 B4

Bindung

- B4 für Nassschliff
- B für Trockenschliff (wenn möglich vermeiden)

Scheibendimension

- Durchmesser D
So gross wie möglich, unter Beachtung der empfohlenen Schnittgeschwindigkeit v.

Schnittdaten

- Schnittgeschwindigkeit v
 - Nassschliff: 18 – 20 m/s
 - Trockenschliff: 10 – 12 m/s

Es ist sehr wichtig, die empfohlene Schnittgeschwindigkeit v nicht zu überschreiten. Höhere Wärmeentwicklung zerstört die Scheibe.

Trennschleifen mit **CBN**

Empfehlung der Zusammensetzung

Kontaktfläche	Trockenschliff	Nassschliff
klein	D 107 C 100 B	B 107 C 100 B3
gross	–	B 107 C 100 B

Trockenschliff sollte möglichst vermieden werden. Das verwendete Kühlmittel sollte eine 5- bis 10-prozentige Emulsion eines HD-Konzentrates sein.

Bindung

- B3 für Nassschliff
- B für Trockenschliff (wenn möglich vermeiden)

Scheibendimension

- Durchmesser D
So gross wie möglich, unter Beachtung der empfohlenen Schnittgeschwindigkeit v.

Schnittdaten

- Schnittgeschwindigkeit v
 - Nassschliff: 25 – 40 m/s
 - Trockenschliff: 20 – 30 m/s



Trennschleifen mit Diamant oder CBN

Form 1A1R

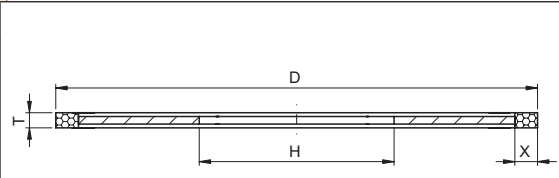
 Bohrung H [mm]: nach Angabe	Abmessungen ¹⁾			Scheibenform
	D [mm]	T [mm]	X [mm]	
	75	1	3	1A1R
	100	1	3	1A1R
	125	1	3	1A1R
	150	1	3	1A1R

Form 3A1

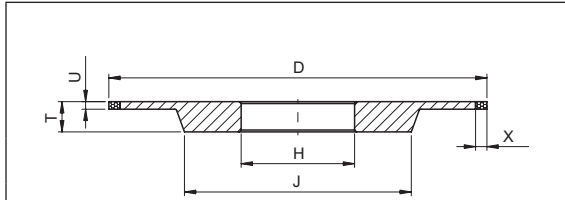
 Bohrung H [mm]: nach Angabe Innenring J [mm]: nach Angabe	Abmessungen ¹⁾			Scheibenform	
	D [mm]	U [mm]	X [mm]		T [mm]
	175	2 / 3	3	8	3A1
	200	2 / 3	3	10	3A1
	250	3 / 5	3	10	3A1
	300	5 / 8	1.5 / 3	10	3A1
	350	5 / 8	1.5 / 3	10	3A1

Bestellbeispiele

- | | |
|---|---|
| <ul style="list-style-type: none"> ■ Diamantscheibe 1A1R
100-1-3-20
B 107 C 100 B | <ul style="list-style-type: none"> ■ Diamantscheibe 3A1
200-3-3-51
D 107 C 100 B4 |
|---|---|

¹⁾ Weitere Abmessungen auf Anfrage



Nutenschleifen mit ► **Diamant**

Empfehlung der Zusammensetzung

Nutentiefe [mm]	weichere Scheibe	Standard
≤ 5	DN 126 C 100 B2A	DG 126 C 100 M27
> 5	DN 126 C 75 B2A	DG 126 C 75 M27

Trockenschliff sollte möglichst vermieden werden. Die weichere Scheibe empfiehlt sich zum Einsatz bei sehr spröden und risseempfindlichen Werkstoffen oder bei unzureichender Kühlung.

Bindung

- B2A . . . für Nassschliff
- M27 . . . für Nassschliff

Schnittdaten

- Schnittgeschwindigkeit v: 15 – 20 m/s
Je grösser die Schnitttiefe, desto niedriger die Schnittgeschwindigkeit.
- Tischvorschub u: 6 – 8 m/min
- Zustellung a: 0.01 – 0.02 mm pro Hub

Beim Tiefschleifen den Tischvorschub soweit reduzieren, dass das Spanvolumen den oben angeführten Werten entspricht.

Nutenschleifen mit ► **CBN**

Empfehlung der Zusammensetzung

Nutentiefe [mm]	weichere Scheibe	Standard
≤ 5	B 126 C 100 B3	BM 126 C 100 M27
> 5	B 126 C 75 B3	BM 126 C 75 M27

Trockenschliff sollte möglichst vermieden werden. Die weichere Scheibe empfiehlt sich zum Einsatz bei sehr spröden und risseempfindlichen Werkstoffen oder bei unzureichender Kühlung.

Bindung

- B3 . . . für Nassschliff
- M27 . . . für Nassschliff

Schnittdaten

- Schnittgeschwindigkeit v: 25 – 40 m/s
- Tischvorschub u: 20 – 30 m/min
- Zustellung a: 0.01 – 0.02 mm pro Hub

Beim Tiefschleifen den Tischvorschub soweit reduzieren, dass das Spanvolumen den oben angeführten Werten entspricht.



Nutenschleifen mit Diamant oder CBN

Form 1A1R

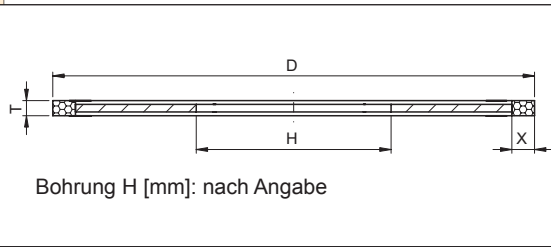

D [mm]	Abmessungen ¹⁾			Scheibenform
	T [mm]	X [mm]		
75	1	3		1A1R
100	1	3		1A1R
125	1	3		1A1R
150	1	3		1A1R

Form 14A1

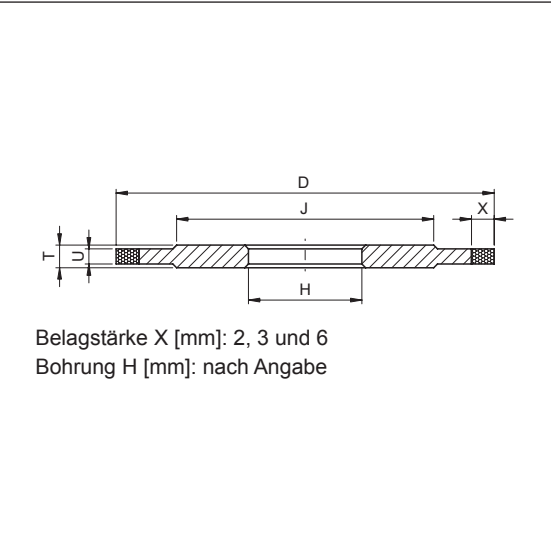

D [mm]	Abmessungen ¹⁾			Scheibenform
	U [mm]	T [mm]	J [mm]	
75	1 / 2 / 3	6	50	14A1
100	1 / 2 / 3	6	70	14A1
125	1 / 2 / 3	6	100	14A1
150	1 / 2 / 3	10	120	14A1
175	3 / 6	10	140	14A1
200	3 / 6	12	160	14A1
250	6 / 10	15	200	14A1
300	6 / 10	15	250	14A1
350	6 / 10	15	300	14A1
400	6 / 10 / 15	20	350	14A1
500	10 / 15	20	400	14A1
600	10 / 15	20	500	14A1

Form 3A1

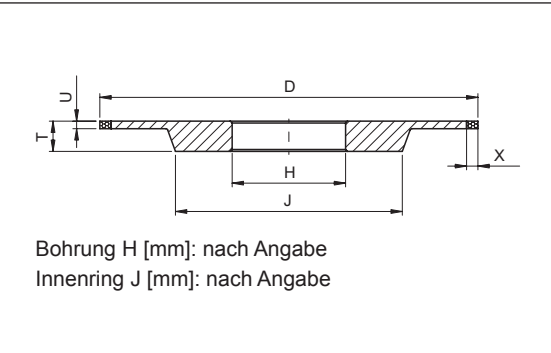

D [mm]	Abmessungen ¹⁾			Scheibenform
	U [mm]	X [mm]	T [mm]	
175	2 / 3	3	8	3A1
200	2 / 3	3	10	3A1
250	3 / 5	3	10	3A1
300	5 / 8	1.5 / 3	10	3A1
350	5 / 8	1.5 / 3	10	3A1

Bestellbeispiele

■ **Diamantscheibe 1A1R**
100-1-3-20
D 107 C 100 B

■ **Diamantscheibe 14A1**
200-3-6-51
D 126 C 100 B2

■ **Diamantscheibe 3A1**
200-3-3-51
D 107 C 100 B4

¹⁾ Weitere Abmessungen auf Anfrage



Sonderausführungen

Form 4A9

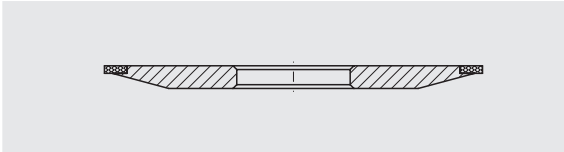

Form 4F9

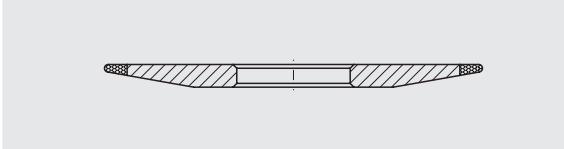

Form 4V5

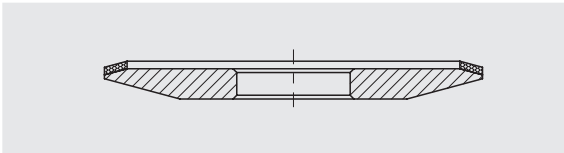

Form 4Y9

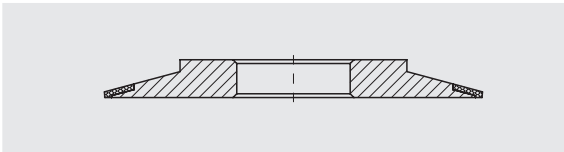

Form 6A2B

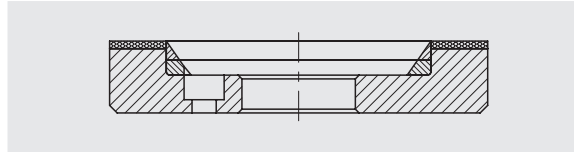

Form 12C9

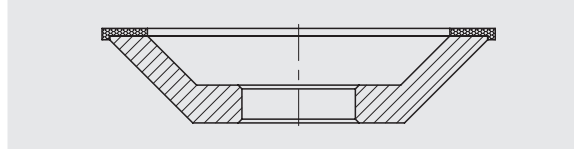

Form 14A1R

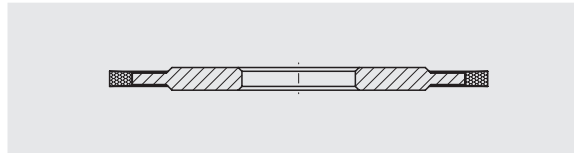

Form 14U1

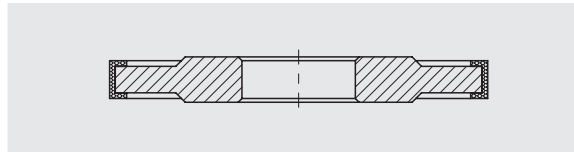

Bestellinformation

- Für Sonderausführungen bitte nebenstehenden Fragebogen verwenden. Ggf. bitte Skizze beifügen.



Fragebogen zur Bestimmung von Diamant- und CBN-Scheiben

Hinweis: vor dem Ausfüllen bitte den Fragebogen kopieren.

Den ausgefüllten Fragebogen mailen Sie an folgende Adresse: info@weiss-diamant.com

Kann eine Schleifscheibe nicht selbst bestimmt werden, bitten wir Sie, soweit wie möglich, folgende Angaben zu machen:

Allgemeine Angaben

Scheibenform (evtl. Skizze)..... Scheibendurchmesser.....

BelagbreiteBelagstärke..... Bohrungsdurchmesser

Kornart und Körnung Konzentration

BindungWinkel..... Radius

Trockenschliff

Nassschliff

Schleifangaben

Werkzeugschleifen allgemein

Fräser/Reibahlen/Senker

Aussenrundscheifen

Drehstähle

Freifläche

Innenschleifen

Freifläche

Spanfläche

Profilschleifen

Spanfläche

Flachschliff

Trennschleifen

Spanleitstufe

Umfangscheibe

Nutenschleifen

Topfscheibe

Tiefschleifen

Sonstige Angaben

Werkstück

Bezeichnung..... Abmessungen.....

Werkstückwerkstoff Nr.

eingesetzt

vergütet

geblüht

Härte.....

Schleifzugabe..... Gewünschte Oberfläche.....

Maschine

Fabrikat..... Typ.....

Drehzahl der Schleifspindel..... 1/min..... Vorschub..... m/min

Zustellung..... mm/Hub



Produktspektrum

Produktion
Formen und Profile
Sicherheit
Schleifanwendungen
Spezifikation
Lagerprogramm Deutschland

→ Seite 4-37
→ Seite 4-38
→ Seite 4-42
→ Seite 4-43
→ Seite 4-46
→ Seite 4-48

Vorteile im Überblick

- Einsatz von hochwertigen Rohstoffen
- Hoher Qualitätsstandard
- Express-Auftrag in zehn Arbeitstagen

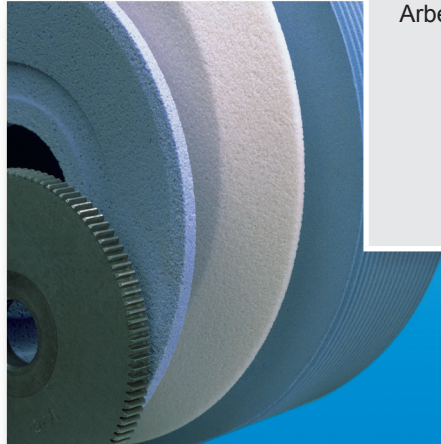
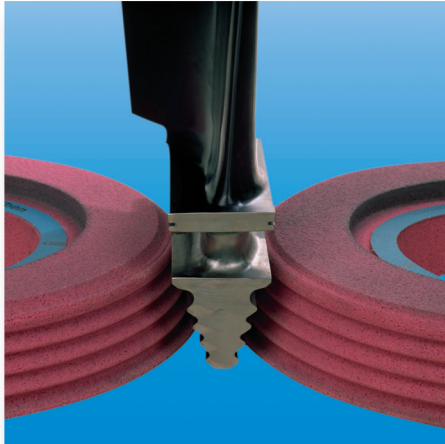

Produktmerkmale

- Herstellung von Schleifkörpern in allen Abmessungen und Formen
- Auf die Anwendung abgestimmte Form und Zusammensetzung

Anwendungsbereiche

- Flachsleifen
- Rundschleifen
- Werkzeugschleifen
- Zahnflankenschleifen
- Gewindeschleifen
- Federendenschleifen und weitere Sonderschleifverfahren

Einsatzbedingungen

- Beachten Sie unsere Hinweise auf den Schleifscheiben und die Sicherheitsempfehlungen in diesem Katalog
→ Seite 4-42



Produktion

1. Mischen

- Eine wesentliche Bedingung für die gleichbleibende Qualität von Schleifkörpern ist die exakte Einhaltung der vorgegebenen Rohstoffmengen. Der Einsatz von elektronischen Wägesystemen garantiert die korrekten Abfüllgewichte innerhalb enger Toleranzen.



2. Pressen

- Zur Gewährleistung der Homogenität der Schleifkörper werden spezielle Zuführeinrichtungen beim Füllen verwendet sowie elektronisch gesteuerte Verteilerrechen. NC-gesteuerte Pressen mit Online-Datenaufzeichnung in der Arbeitsvorbereitung sind eine weitere Voraussetzung für eine reproduzierbare Scheibenstruktur.

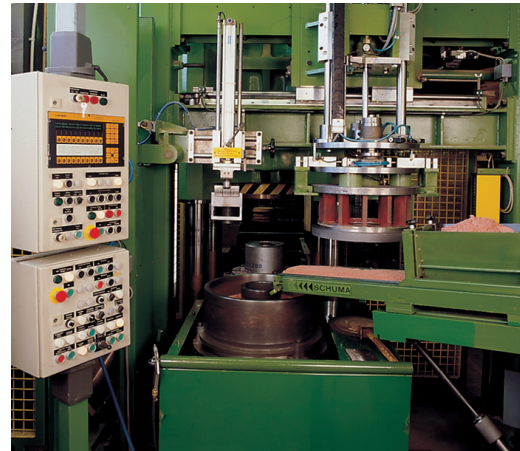

3. Nachbearbeitung

- Durch die Nachbearbeitung erhält der Schleifkörper seine endgültige Form. Hier steht ein vielfältiger Maschinenpark zur Verfügung. So sind selbst anspruchsvolle Geometrien mit entsprechenden Toleranzen bei gleichzeitig hoher Produktivität möglich.

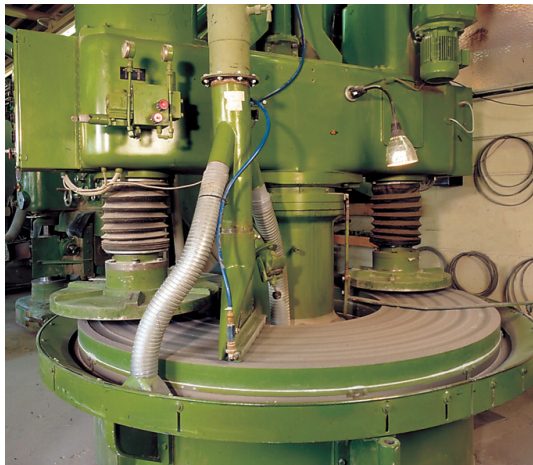

4. Ofen

- Die Brenntemperatur keramischer Schleifkörper liegt zwischen 1000 °C und 1300 °C. Eine elektronische Steuerung des Brennverlaufs verhindert die Abweichung von den festgelegten Brennkurven. Gleichzeitig wird der Brennzyklus auftragsbezogen dokumentiert.





Formen und Profile – ISO-Formen

Es werden Schleifkörper in allen Abmessungen und Formen produziert. Die gängigsten sind hier mit ihren ISO-Formnummern und Randformen aufgeführt.

Davon abweichende Scheiben können nach Zeichnung angefragt und bestellt werden.

	Bezeichnung	Abmessungen	ISO-Form-Nr.
	Gerade Schleifscheibe	$D \times H \times T$	1
	Schleifzylinder mit Tragscheibe verklebt	$D \times T - W$	2
	Gerade Schleifscheibe zweiseitig konisch	$D/J \times T/U \times H$	4
	Gerade Schleifscheibe einseitig ausgespart	$D \times T \times H - P \times F$	5
	Zylindrischer Schleiftopf	$D \times T \times H - W..E..$	6
	Gerade Schleifscheibe zweiseitig ausgespart	$D \times T \times H - P \times F / G$	7
	Kegeliger Schleiftopf	$D/J \times T \times H - W..E..K$	11
	Schleifteller	$D/J \times T/U \times H - W..E..K$	12

Fortsetzung siehe nächste Seite

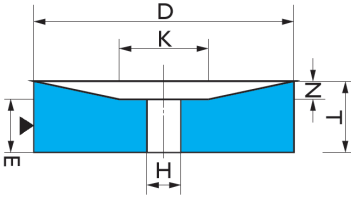
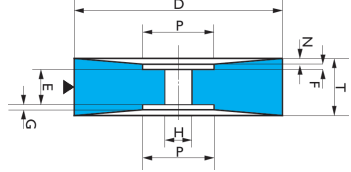
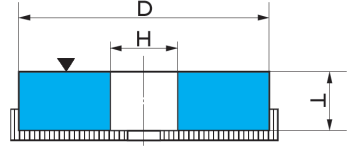
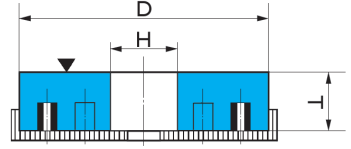
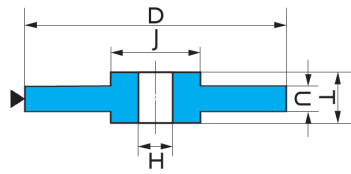
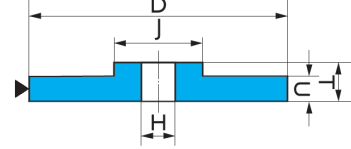
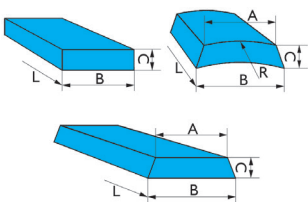

	Bezeichnung	Abmessungen	ISO-Form-Nr.
	Gerade Schleifscheibe einseitig verjüngt	D/J x T/U x H - W..E..K	20
	Gerade Schleifscheibe zweiseitig ausgespart und zweiseitig verjüngt	D x T/N x H - P x F/G	26
	Gerade Schleifscheibe mit Tragscheibe verklebt	D x T x H	35
	Gerade Schleifscheibe mit Tragscheibe verschraubt	D x T x H Gewindebuchsen	36
	Gerade Schleifscheibe zweiseitig abgesetzt	D/J x T/U x H	39
	Gerade Schleifscheibe einseitig abgesetzt	D/J x T/U x H	38
	Schleifsegmente	B x C x L und B/A x C x L R nach Angabe	31



Formen und Profile – Randformen





Formen und Profile – Schleifstifte

Standardformen nach DIN-Norm

- Die DIN-Norm kennt sieben Schleifstiftformen.
- Die Abmessung wird mit acht Zeichen festgelegt.
Beispiel in folgender Tabelle: ZY 40 20 06

Zeichen	Beschreibung	Beispiel / Legende	
1 und 2	Kurzbezeichnung der Form	ZY	
3 und 4	Grösster Durchmesser D in mm	40	
5 und 6	Grösste Länge T in mm ¹⁾	20	
7 und 8	Schaftdurchmesser S in mm	06	

¹⁾ entfällt bei Form KU

Darüber hinaus wird zwischen der W-Reihe (zylindrische Stifte) und der A- und B-Reihe (Formstifte) unterschieden. Wegen der Vielfalt der Formen können wir diese hier nicht auführen.

Fragen Sie diese bitte mit einer Skizze an. Wir können Sie in den meisten Fällen ab Lager beliefern.

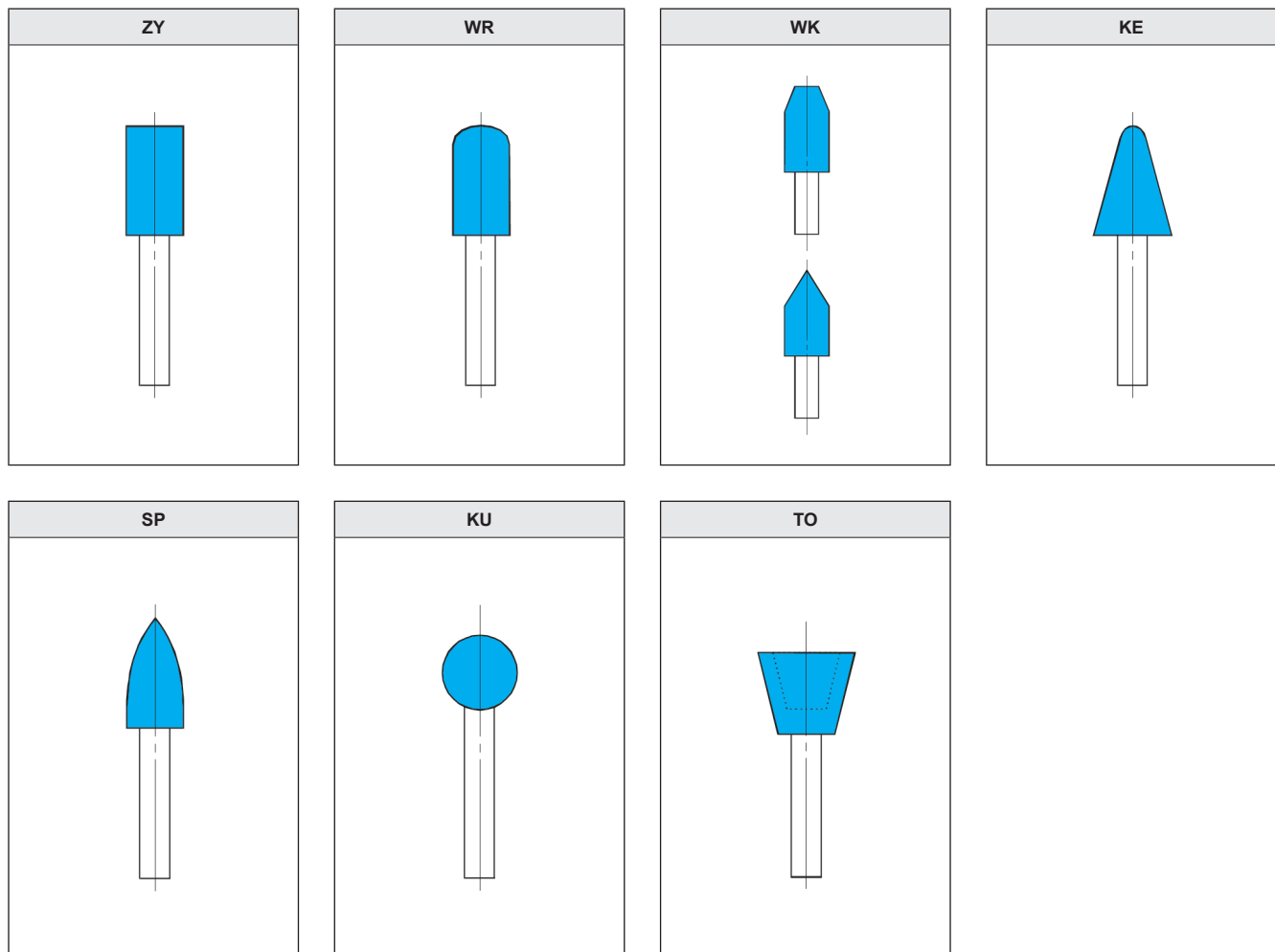



Sicherheitsempfehlungen

Die heute verfügbaren Schleifwerkzeuge sind sichere Arbeitsmittel. Beschädigte, falsch aufgespannte oder eingesetzte Schleifkörper sind jedoch gefährliche Werkzeuge, deren Verwendung zu schwerwiegenden Verletzungen und

Beschädigungen führen kann. Die folgende Aufstellung enthält nur die wichtigsten Sicherheitshinweise in Kurzform. Es sind folgende Sicherheitshinweise zu beachten:

Allgemeine Sicherheitsempfehlungen



Augenschutz



Handschuhe benutzen



Staubmaske benutzen



Gehörschutz benutzen

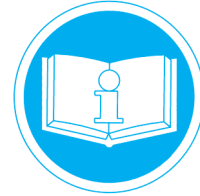

Sicherheitsempfehlung beachten

1. Handhabung, Transport und Lagerung

- Verpackung und Inhalt bei Anlieferung auf Beschädigung prüfen
- Schleifkörper sind bruchempfindlich: nicht fallenlassen, stossen, etc.
- Lagerung ohne mechanische Beschädigung, Frost, Feuchtigkeit, einseitige Erwärmung, aggressive Medien
- Schleifkörper in Kunstharzbindung nicht über zwei Jahre lagern

2. Auswahl des Schleifkörpers und Aufspannen

- Überprüfen, ob die maximale Spindeldrehzahl der Maschine die auf dem Etikett oder dem Schleifkörper angegebene maximale Drehzahl nicht übersteigt
- Verwendungseinschränkungen und Hinweise (siehe Piktogramme) beachten
- Sichtprüfung auf Risse, Ausbrüche, etc.
- Klangprobe, besonders bei keramisch gebundenen Schleifkörpern ab 80 mm Aussendurchmesser

- Aufspannen nur durch sachkundige Personen
- Die Spannflansche müssen sauber, plan, hinterdreht und gleich geformt sein. Im Allgemeinen müssen sie ein Drittel des Schleifscheibendurchmessers abdecken
- Zwischen Schleifkörper und Spannflansch sind Zwischenlagen aus einem weichen oder elastischen Stoff (Kunststoff, Papier, Gummi) zu legen
- Soweit vorhanden mit der Auswuchtvorrichtung die Unwucht minimieren
- Schutzhaube überprüfen
- Persönliche Schutzausrüstung der Arbeit anpassen (Augen- und Gehörschutz, Schürze, Sicherheitsschuhe, etc.)

3. Inbetriebnahme

- Probelauf bei gesichertem Arbeitsbereich
- Unter Umständen abrichten
- Kühlschmierstoffzufuhr erst nach dem Anlaufen einschalten und vor dem Abschalten der Maschine sperren
- Arbeitsplatz sichern (Funken, Stäube, Dämpfe, Aerosole)

FEPA Sicherheitsempfehlungen



Nicht zulässig für Seitenschleifen



Nicht zulässig für Nassschleifen



Nicht zulässig für Freihandschleifen und Freihandtrennschleifen



Beispielanwendungen für Flachsleifen

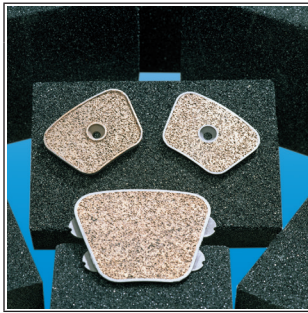

Flugzeugbremsbeläge

Segmente erlauben die Bearbeitung grosser Flächen bei entsprechend hoher Produktivität. Die Aufspannung auf die Maschine erfolgt ringförmig mit Zwischenabständen, was ermöglicht, sowohl einzelne grosse Werkstücke wie auch Serien kleinerer Teile zu bearbeiten.

Die abgebildeten Flugzeugbremsbeläge werden mit Segmenten aus schwarzem Siliziumkarbid auf das Fertigmass für den Einbau plangeschliffen.

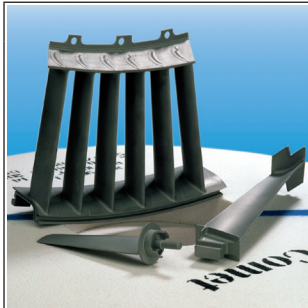

Flugzeugturbinen

Für die Bearbeitung von hochlegierten Werkstoffen wie diesem hochwarmfesten Stahl einer Flugzeugturbine empfehlen wir hochporöse Schleifscheiben in Edelmetallkorund. Der hohe Porenanteil und die geringe Härte ermöglichen extreme Schnitfähigkeit und optimales Zeitspanvolumen selbst bei zähen Materialien.

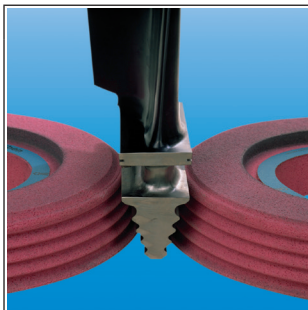

Turbinenschaufelfuss

Beim Flachsleifen kommen weiche und hochporöse Schleifscheiben zum Einsatz. Ein Turbinenschaufelfuss wird hier im Vollschnittverfahren in einem Durchgang auf Fertigmass geschliffen. Ziel ist, das Werkstück auch bei sehr hoher Zerspanung nur gering zu belasten, um thermische Schädigung zu vermeiden.



Zangenrohlinge

Ebenfalls in einem Durchgang fertiggeschliffen werden die Köpfe dieser im Gesenk geschmiedeten Zangenrohlinge. Die Profilierung der Schleifscheibe erfolgt durch Diamantabrichtrollen, die entweder kontinuierlich im CD-Verfahren (continuous dressing) oder zyklisch im Einsatz sind. Neben dem Porenvolumen und dessen homogener Verteilung ist die richtige Auswahl des Bindemitteltyps für den Erfolg ausschlaggebend. Hier verfügen wir dank besonderer Fertigungsmethoden und Rohstoffe über ein ausgezeichnetes Know-How.



Kugellager planschleifen

Die beidseitige Präzisionsbearbeitung erfolgt mit dem Ziel hoher Planparallelität und Oberflächengüte. Beim Seitenschleifen laufen meist kunstharzgebundene Schleifscheiben im Satz und erreichen hohe Produktivität. Zur Montage auf die Maschine, z. B. Typ Diskus oder Gardner, werden sie entweder geklebt oder mit Hilfe eingelassener Muttern geschraubt.



Beispielanwendungen für Rundschleifen



Turboladerturbine

Bei dieser anspruchsvollen Schleifaufgabe, der Fertigung einer Turboladerturbine, werden fünf Aussenrund-Schleifoperationen durchgeführt. Das Werkstück besteht aus einem hochwarmfesten, stark legierten Gusskopf, der durch Reibschweißen mit dem Stiel aus sehr zähem Material verbunden wurde. Mit einer Zweischichtscheibe wird im Schrägeinstechschleifen die Planfläche des Kopfes, die Schweissstelle und der Stiel über die gesamte Länge in einem Durchgang geschliffen, um die geforderte Geometrie herzustellen. Dabei wird mit der zweiten Schicht in weissem Edelkorund dem vom Stiel abweichenden Material und der Gefahr von Überhitzung Rechnung getragen.



Bremszylinder

Werkstücke mit konstantem Durchmesser können im Spitzenlos-Durchgangsschleifen bearbeitet werden. Dieser Bremszylinder wird über ein Lineal kontinuierlich der Schleifzone zugeführt. Zwischen einer gummi gebundenen Regelscheibe und einer keramisch oder kunstharz gebundenen Arbeitsscheibe wird hier der geforderte Abtrag erzielt. Je nach Länge der Schleifzone und der geforderten Abtragsleistung wird mit unterschiedlichen Körnungen gleichzeitig vor- und fertiggeschliffen.



Sonderteile

Aufgrund ihrer Geometrie können diese Teile nicht zwischen Spitzen gespannt und somit nicht im Durchgangsschleifen bearbeitet werden. Sie durchlaufen das Spitzenlos-Einstechschleifen. Auch hier werden die Werkstücke durch eine Regelscheibe in Rotation versetzt und mit Hilfe eines Lineals geführt. Die Arbeitsscheibe hat jedoch im Vergleich zum Durchgangsschleifen eine höhere Härte, um eine bessere Profilhaltigkeit zu erreichen.

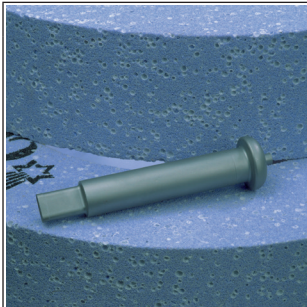

Spritzgussform

Beim Aussenrundschleifen empfehlen wir selten hochporöse Schleifscheiben. In diesem konkreten Anwendungsfall ist ihr Einsatz jedoch sinnvoll, da die zu bearbeitende Spritzgussform hochlegiert und sehr hart ist. Die Porosität wird hier nicht durch Ausbrennstoffe sondern durch Kugelkorund erzeugt.



Kugellager

Neben anderen schleifintensiven Produktionsschritten werden in der Wälzlagerindustrie u. a. die Aussenringe der Kugellager innenrundgeschliffen. Da in der Regel ähnliche Stähle Verwendung finden, meist 100 Cr 6 mit 62 – 65 HRC, werden Schleifscheiben in Halbkorund oder in Edelkorund eingesetzt.



Beispielanwendungen für Werkzeugschleifen

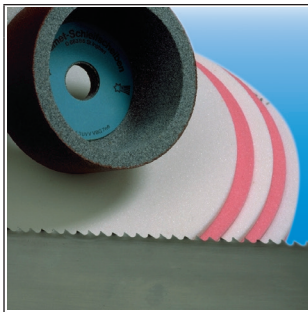

Sägen

Sägen sind ein typisches und variantenreiches Beispiel des Werkzeugschleifens. Es wird unterschieden zwischen Produktionsschleifen und Schärfen, zwischen den Anwendungen (Holz oder Metall) und der Form der Säge (Bügel-, Kreis-, Gatter- oder Bandsäge).

Beispielanwendungen für Sonderschleifverfahren

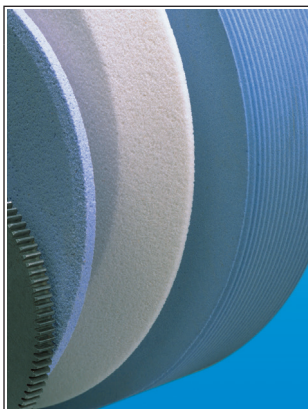

Zahnflanken

Das Zahnflankenschleifen ist eine sehr anspruchsvolle Aufgabe, da hier einige für den Schleifprozess ungünstige und sich widersprechende Anforderungen aufeinandertreffen:

- die Stähle sind meist hochlegiert und gehärtet
- Oberfläche und Geometrie bewegen sich in sehr engen Toleranzen
- es dürfen keine Oberflächenfehler und Überhitzungen auftreten
- die Kontaktfläche mit dem Werkstoff ist sehr gross

Drei Schleifverfahren können unterschieden werden:

- Maag: zwei Tellerschleifscheiben, Trockenschliff
- Höfler, Niles: beidseitig am Umfang 20° abgeschrägte Schleifscheiben
- Reishauer: Schleifscheiben mit ein- oder zweigängigem Schraubenprofil



Gewinde

Gewinde und Bohrnuten werden heute meist im Vollschnittverfahren (z. B. Gühring) erzeugt. Die Wahl der Körnung und Härte ergibt sich hier durch Steigung und Feinheit des Profils. Der abgebildete Gewindebohrer wird mit einer keramischen Schleifscheibe in weissem Edelkorund bei einer Umfangsgeschwindigkeit von 80 m/s hergestellt.



Federn

Beim Federnendenschleifen ist die schwer zu realisierende Kühlung die technische Herausforderung. Der sehr schnittige Sinterkorund hat daher in letzter Zeit grosse Verbreitung gefunden.

Die Zusammensetzung der Schleifscheibe wird festgelegt gemäß

- Stahlqualität und Wärmebehandlung
- Durchmesser des Drahtes und der Feder
- geforderter Geometrie

Daraus ergibt sich stark vereinfacht:





- kleine Federn bzw. dünner Draht: formhaltige relativ harte Scheiben in Keramikbindung
- grosse Federn bzw. dicker Draht: grobkörnige, poröse, weiche Scheiben in Kunstharzbindung







Spezifikation und Qualitätsbezeichnungen von Schleifscheiben

Nach DIN 69100 wird die Qualität einer Schleifscheibe durch fünf Komponenten bestimmt, die im Folgenden näher beschrieben werden.

1. Schleifmittel

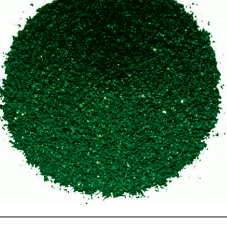
	Schleifmittel	Typ
	Normalkorund	10A
	Spezialkorund	20A
	Einkristallkorund	30A
	Edelkorund weiss	40A
	Edelkorund rosa	50A

	Schleifmittel	Typ
	Rubina	60A
	Kugelkorund	70A
	Sinterkorund	80A
	Siliziumkarbid grün	10C
	Siliziumkarbid schwarz	20C
–	Schleifmittelmischungen	41A, 21C, etc.

Fortsetzung und Bestellbeispiel siehe nächste Seite



2. Körnung

Bezeichnung	Körnung
grob	6, 8, 10, 12, 14, 16, 20, 24
mittel	30, 36, 46, 60
fein	80, 100, 120, 150, 180
sehr fein	220, 240, 280, 320, ...

3. Härte

Bezeichnung	Härte
sehr weich	D, E, F, G
weich	H, I, J, K
mittel	L, M, N, O
hart	P, Q, R, S
sehr hart	T, U, V, W

4. Gefüge

		Gefüge	Typ
	geschlossen	1	
		2	
		3	
		4	
		5	
		6	
		7	
		8	
		9	
		10	
		11	
		12	
		13	
	offen	14	

5. Bindung

Bezeichnung	Bindung
V	Keramische Verbindung
B	Kunstharzbindung
BF	Kunstharzbindung faserverstärkt
R	Gummibindung

Bestellbeispiel

Bestellbeispiel für:

Schleifbockscheibe gerade, Durchmesser x Breite x Bohrungsdurchmesser,
 Normalkorund, Körnung mittel, Härte hart, Gefüge, keramische Bindung

■ Schleifbockscheibe Form 1 150x20x32 10A 36 P 7 V



Schleifbockscheiben

- Gerade (ISO-Form 1) und ausgespart (ISO-Form 5)
- Die Bohrung kann jeder Maschine angepasst werden

Schleifmittel

- 10A-Normalkorund: Baustähle und weiche, niedriglegierte Stähle
- 50A-Edelkorund rosa: legierte, gehärtete HSS-Stähle
- 10C-Siliziumkarbid: Hartmetall

Scheiben-Durchmesser 100 mm

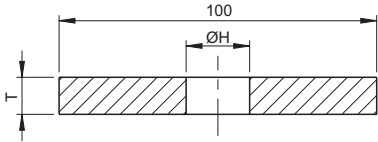
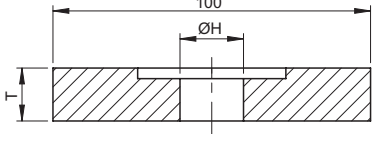
 ISO-Form 1	Abmessungen		Schleifmittel	Spezifikation
	T [mm]	ØH [mm]		
 ISO-Form 5	20	20	10A	10A 60 M 7 V
			50A	50A 60 M 7 V
	10C	10C 60 K 7 V		
		10C 100 J 7 V		

Scheiben-Durchmesser 125 mm

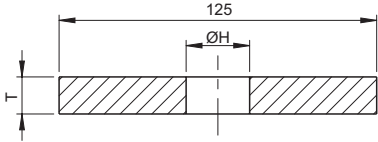
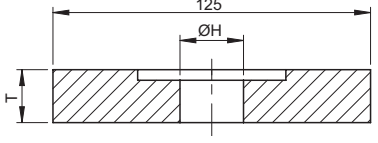
 ISO-Form 1	Abmessungen		Schleifmittel	Spezifikation
	T [mm]	ØH [mm]		
 ISO-Form 5	20	25	10A	10A 36 P 7 V
			10A 60 M 7 V	
			50A	50A 60 M 7 V
25	32	10C	10C 100 J 7 V	
		10A	10A 36 P 7 V	
		10A 60 M 7 V		
		50A	50A 60 M 7 V	
		10C 60 K 7 V		
		10C 100 J 7 V		

Fortsetzung siehe nächste Seite, Bestellbeispiel → Seite 4-52

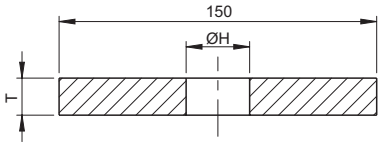
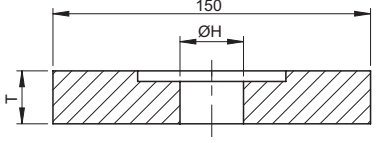

Scheiben-Durchmesser 150 mm

	Abmessungen		Schleifmittel	Spezifikation
	T [mm]	ØH [mm]		
 <p>ISO-Form 1</p>  <p>ISO-Form 5</p>	20	32	10A	10A 36 P 7 V 10A 60 M 7 V
			50A	50A 36/46 N 7 V 50A 46/60 K 7 V 50A 60 M 7 V
			10C	10C 80 JK 7 V 10C 80 M 7 V 10C 120 J 7 V
	25	32	10A	10A 36 P 7 V 10A 60 M 7 V
			50A	50A 36/46 N 7 V 50A 46/60 K 7 V 50A 60 M 7 V 50A 80 K 7 V
			10C	10C 60 K 7 V 10C 80 JK 7 V 10C 120 J 7 V
	80	8	10A	10A 60 M 7 V
			10C	10C 80 M 7 V

Scheiben-Durchmesser 175 mm

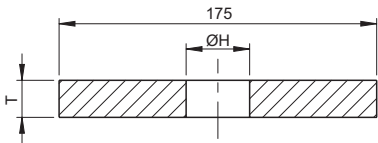
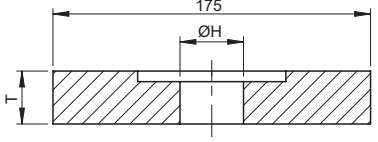
	Abmessungen		Schleifmittel	Spezifikation
	T [mm]	ØH [mm]		
 <p>ISO-Form 1</p>  <p>ISO-Form 5</p>	20	32	10A	10A 24/36 P 7 V 10A 60 M 7 V
			50A	50A 36/46 N 7 V 50A 60 M 7 V
			10C	10C 80 JK 7 V 10C 120 J 7 V
	25	32	10A	10 A 24/36 P 7 V 10 A 60 M 7 V 10 A 80 L 7 V
			50A	50A 36/46 N 7 V 50A 46/60 K 7 V 50A 60 M 7 V 10C 60 K 7 V
			10C	10C 80 JK 7 V 10C 120 J 7 V
		51	10A	10A 24/36 P 7 V 10A 60 M 7 V
			50A	50A 36/46 N 7 V 50A 60 M 7 V
			10C	10C 80 JK 7 V 10C 120 J 7 V
	32	32	10A	10A 24/36 P 7 V 10A 60 M 7 V 10A 80 L 7 V
			50A	50A 36/46 N 7 V 50A 46/60 K 7 V 50A 60 M 7 V 10C 60 K 7 V
			10C	10C 80 JK 7 V 10C 120 J 7 V

Fortsetzung siehe nächste Seite, Bestellbeispiel → Seite 4-52

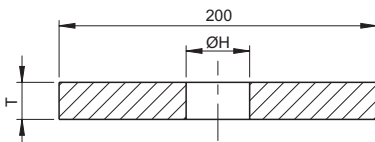
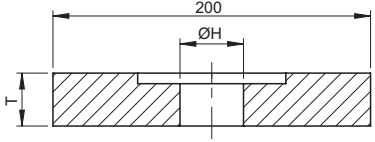

Scheiben-Durchmesser 200 mm

	Abmessungen		Schleifmittel	Spezifikation	
	T [mm]	ØH [mm]			
 <p>ISO-Form 1</p>	20	32	10A	10A 24 Q 7 V 10A 36/46 O 7 V 10A 60 M 7 V	
			50A	50A 36/46 N 7 V 50A 46/60 K 7 V 50A 60 M 7 V	
			10C	10C 60 K 7 V 10C 80 JK 7 V 10C 120 J 7 V	
			10A	10A 24 Q 7 V 10A 36/46 O 7 V 10A 60 M 7 V	
			50A	50A 36/46 N 7 V 50A 46/60 K 7 V 50A 60 M 7 V	
			10C	10C 80 JK 7 V 10C 120 J 7 V	
	 <p>ISO-Form 5</p>	25	32	10A	10A 24 Q 7 V 10A 36/46 O 7 V 10A 60 M 7 V
				50A	50A 36/46 N 7 V 50A 46/60 K 7 V 50A 60 M 7 V
				10C	10C 60 K 7 V 10C 80 JK 7 V 10C 120 J 7 V
				10A	10A 24 Q 7 V 10A 36/46 O 7 V 10A 60 M 7 V
				50A	50A 36/46 N 7 V 50A 46/60 K 7 V 50A 60 M 7 V
				10C	10C 80 JK 7 V 10C 120 J 7 V
		32	32	10A	10A 24 Q 7 V 10A 36/46 O 7 V 10A 60 M 7 V
				50A	50A 36/46 N 7 V 50A 46/60 K 7 V 50A 60 M 7 V
				10C	10C 60 K 7 V 10C 80 JK 7 V 10C 120 J 7 V
				10A	10A 24 Q 7 V 10A 36/46 O 7 V 10A 60 M 7 V
				50A	50A 36/46 N 7 V 50A 46/60 K 7 V 50A 60 M 7 V
				10C	10C 80 JK 7 V 10C 120 J 7 V
	40	51	51	10A	10A 24 Q 7 V 10A 36/46 O 7 V 10A 60 M 7 V
				50A	50A 36/46 N 7 V 50A 46/60 K 7 V 50A 60 M 7 V
				10C	10C 80 JK 7 V 10C 120 J 7 V
				50A	50A 46/60 K 7 V
				10C	10C 60 J 7 V
				110	25
			10C	10C 60 J 7 V	

Fortsetzung siehe nächste Seite, Bestellbeispiel → Seite 4-52

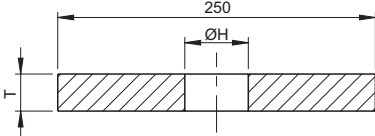
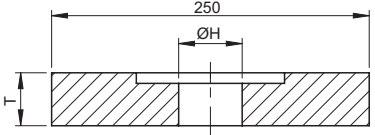

Scheiben-Durchmesser 250 mm

 ISO-Form 1	Abmessungen		Schleifmittel	Spezifikation
	T [mm]	ØH [mm]		
 ISO-Form 5	25	51	10A	10A 24 Q 7 V 10A 36/46 O 7 V 10A 60 M 7 V
			50A	50A 46/60 L 7 V
			10C	10C 60 K 7 V 10C 80 J 7 V
	40	51	10A	10A 24 Q 7 V 10A 36/46 O 7 V 10A 60 M 7 V
			50A	50A 36 M 7 V 50A 46/60 L 7 V
			10C	10C 46 K 7 V 10C 60 K 7 V 10C 80 J 7 V

Scheiben-Durchmesser 300 mm

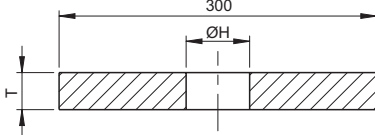
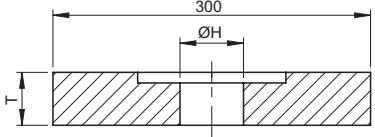
 ISO-Form 1	Abmessungen		Schleifmittel	Spezifikation	
	T [mm]	ØH [mm]			
 ISO-Form 5	32	51	10A	10A 24 Q 7 V 10A 46 N 7 V	
			50A	50A 36 LM 7 V 50A 60 KL 7 V	
			10C	10C 46 K 7 V 10C 60 JK 7 V	
	40	32	10A	10A 24 Q 7 V 10A 46 N 7 V 10A 60 M 7 V	
			51	10A	10A 24 Q 7 V 10A 46 N 7 V 10A 60 M 7 V
				50A	50A 36 LM 7 V 50A 60 KL 7 V
	50	76	10C	10C 46 K 7 V 10C 60 JK 7 V 10C 80 J 7 V	
			10A	10A 24 Q 7 V 10A 46 N 7 V 10A 60 M 7 V	
			50A	50A 36 LM 7 V 50A 60 KL 7 V	
	125	19	10C	10C 46 K 7 V 10C 60 JK 7 V	
			10A	10A 24 Q 7 V 10A 46 N 7 V 10A 60 M 7 V	
			50A	50A 36 LM 7 V 50A 60 KL 7 V	

Fortsetzung und Bestellbeispiel siehe nächste Seite

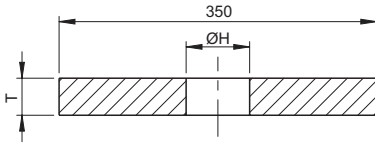
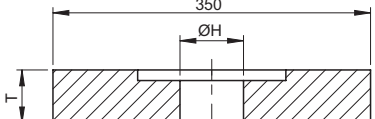

Scheiben-Durchmesser 350 mm

 ISO-Form 1	Abmessungen		Schleifmittel	Spezifikation
	T [mm]	ØH [mm]		
 ISO-Form 5	40	76	10A	10A 20/2 Q 7 V
			50A	10A 46 N 7 V
			10C	50A 36 LM 7 V
	50	76	10A	50A 60 KL 7 V
			50A	10C 46 K 7 V
				10A 20/2 Q 7 V
			10A	10A 46 N 7 V
	127	10A	50A 36 LM 7 V	
			50A 60 KL 7 V	
			10A 20/2 Q 7 V	
			10A 46 N 7 V	

Scheiben-Durchmesser 400 mm

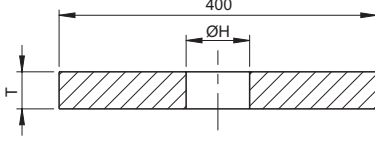
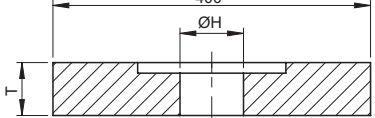
 ISO-Form 1	Abmessungen		Schleifmittel	Spezifikation
	T [mm]	ØH [mm]		
 ISO-Form 5	40	76	10A	10A 20/2 Q 7 V
				10A 46 N 7 V
			50A	50A 36 LM 7 V
	50	76	10A	50A 60 KL 7 V
				10A 20/2 Q 7 V
			50A	50A 36 LM 7 V

Bestellbeispiel

- Schleifbockscheibe: ISO-Form 1, Durchmesser D: Ø300 mm, Breite T: 40 mm, Bohrung H: 51 mm,
- Scheibentyp 10A 60 M 7 V

Spezifikation Scheibentyp → [Seite 4-46](#)



Werkzeug-Schleifscheiben

■ Zum Schleifen und Schärfen von Werkzeugen aus hochlegierten Werkzeugstählen

Gerade Topfscheiben (ISO-Form 6)

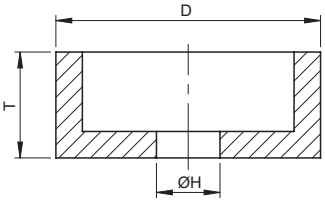

	Abmessungen			Schleifmittel	Spezifikation
	D [mm]	T [mm]	ØH [mm]		
100	50	20		40A	40A 46 J 7 V
					40A 54/I J 8 VY
					40A 60 J 8 VY
				60A	40A 80 I 7V
					40A 80 K 7 VY
					60A 60/2 J 8 VY
	80	40		40A	41A 80 J 7 V
					40A 46 J 7 V
					40A 54/I J 8 VY
				60A	40A 60 J 8 VY
					40A 80 I 7V
					40A 80 K 7 VY
150	50	32	40A	60A 60/2 J 8 VY	
				41A 80 J 7 V	
				40A 54/I J 8 VY	
	63	32	60A	40A 60 K 8 VY	
				60A 46/1 K 8 VY	
				60A 54/1 K 8 VY	
	130	37	40A	60A 60/2 J 8 VY	
				40A 54/I J 8 VY	
				40A 60 K 8 VY	
		47	60A	60A 46/1 K 8 VY	
				60A 54/1 K 8 VY	
				60A 60/2 J 8 VY	
200	95	76.2	40A	40A 36 J 8 VY	
				40A 46 I 8 VY	
				60A 36/I K 9 VY	
	160	70	40A	40A 36 J 8 VY	
				40A 46 I 8 VY	
				60A 36/I K 9 VY	

Konische Topfscheiben (ISO-Form 11)

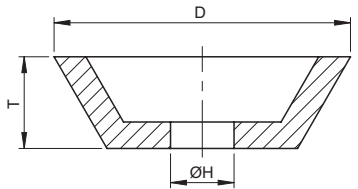

	Abmessungen			Schleifmittel	Spezifikation
	D [mm]	T [mm]	ØH [mm]		
80	50	13	40A	40A 60 K 8 VY	
100	40	20	40A	40A 46 JK 7 V	
				40A 60 J 7 V	
	50	20	60A	40A 80 K 8 VY	
125	40	20	40A	60A 60/2 J 8 VY	
				40A 46 JK 7 V	
				40A 60 J 7 V	
150	50	32	40A	40A 46 K 8 VY	

Fortsetzung und Bestellbeispiel siehe nächste Seite

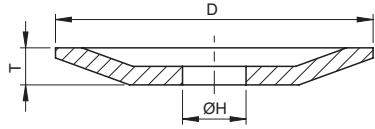

Tellerscheiben (ISO-Form 12)

	Abmessungen			Schleifmittel	Spezifikation	
	D [mm]	T [mm]	ØH [mm]			
	150	13	20	40A	40A 46 K 6 VY	
						40A 60 J 8 VY
						40A 46 JK 7 V
			15	20	40A	40A 60 J 7 V
						40A 60 K 7 V
					41A	41A 46/60 IJ 7 V

Bestellbeispiel

- Werkzeug-Schleifscheibe: ISO-Form 11, Durchmesser D: Ø125 mm, Breite T: 40 mm, Bohrung H: 20 mm,
- Scheibentyp 40A 60 J 7 V

Spezifikation Scheibentyp → [Seite 4-46](#)

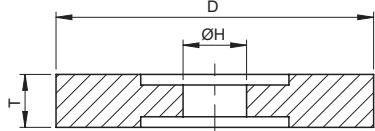

Flachschleifen

 ISO-Form 7	Abmessungen			Material		
	D [mm]	T [mm]	ØH [mm]	Werkstück	Schleifmittel	Spezifikation
	155	10	10	ungehärtet	40A	40A 46 J 7 V
				gehärtet	40A	40A 36/46 H 7 V
	300	50	76	ungehärtet	40A	40A 46 J 7 V
				gehärtet	40A	40A 36/46 H 7 V

Bestellbeispiel

- Flachschleifen-Schleifscheibe: ISO-Form 7, Durchmesser D: Ø155 mm, Breite T: 10 mm, Bohrung H: 10 mm
- Scheibentyp 40A 46 H 7 V

Spezifikation Scheibentyp → [Seite 4-46](#)



Sägeschürfscheiben

- Die Bohrung kann jeder Maschine angepasst werden

Kettensägen

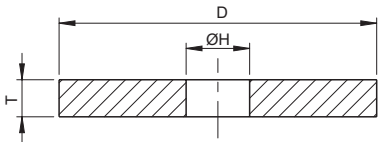
	Abmessungen			Schleifmittel	Spezifikation
	D [mm]	T [mm]	ØH [mm]		
140	3.3	12	41A	41A 60/2 N 7 V	
	4.5	12	41A	41A 60 N 7 V	

Zweischicht-Sägeschürfscheiben für Stellitebestückte Kreissägen

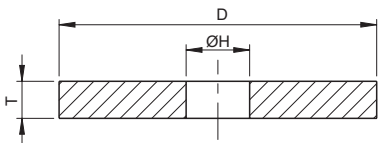
	Abmessungen			Schleifmittel	Spezifikation
	D [mm]	T [mm]	ØH [mm]		
200	12	32	40A	40A 60 M 7 V	
			50A	50A 46 N 7 V	
250	12	32	40A	40A 60 M 7 V	
			50A	50A 46 N 7 V	

Sägeschürfscheiben für Holz- und Metallsägen

- weich: z. B. für Gattersägen
- mittel: z. B. für Kreissägen
- hart: z. B. für Bandsägen

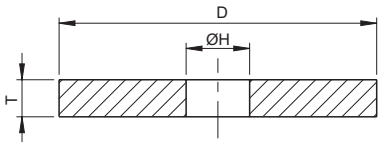
	Abmessungen			Material		Spezifikation
	D [mm]	T [mm]	ØH [mm]	Werkstück	Schleifmittel	
150	1.0	20	hart	50A	50A 100/7 M 4 V	
	1.5	20	hart	50A	50A 100/7 M 4 V	
	2.0	20	hart	50A	50A 80/2 O 4 V	
	2.5	20	hart	50A	50A 80/2 O 4 V	
	3.0	20	hart	50A	50A 80/2 O 4 V	
	4.0	20	hart	40A	40A 80 MN 7 V	
	6.0	20	mittel	40A	40A 60 LM 7 V	
			hart	40A	40A 60 MN 7 V	
	8.0	20	mittel	40A	40A 60 LM 7 V	
hart			40A	40A 60 MN 7 V		

Fortsetzung siehe nächste Seite, Bestellbeispiel → Seite 4-58



	Abmessungen			Material		
	D [mm]	T [mm]	ØH [mm]	Werkstück	Schleifmittel	Spezifikation
	200	1.0	20	hart	50A	50A 100/7 N 4 V
		1.5	20	hart	50A	50A 100/7 N 4 V
		2.0	20	hart	50A	50A 80/2 O 4 V
		2.5	20	hart	50A	50A 80/2 O 4 V
		3.0	20	hart	50A	50A 80/2 O 4 V
		6.0	20	weich	40A	40A 60 KL 7 V
				mittel	40A	40A 60 LM 7 V
				hart	40A	40A 60 MN 7 V
		8.0	20	weich	40A	40A 60 KL 7 V
				mittel	40A	40A 60 LM 7 V
				hart	40A	40A 60 MN 7 V
		10.0	20	weich	40A	40A 46/2 KL 7 V
	mittel			40A	40A 60 LM 7 V	
	12.0	20	weich	40A	40A 46/2 KL 7 V	
			mittel	40A	40A 60 LM 7 V	
	250	10.0	weich	40A	40A 46/2 KL 7 V	
			mittel	40A	40A 46/2 LM 7 V	
		12.0	20	weich	40A	40A 46/2 KL 7 V
mittel				40A	40A 46/2 LM 7 V	

Fortsetzung und Bestellbeispiel siehe nächste Seite



Kunsthharzgebundene Sägeschärf-scheiben

- Umfangsgeschwindigkeit bis 80 m/s
- Schärfe feiner Verzahnung, Trennen von Werkzeugstählen, Schleifen von Nuten, etc.

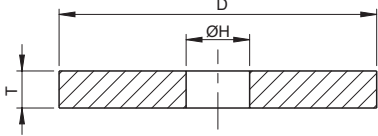
	Abmessungen			Schleifmittel	Spezifikation
	D [mm]	T [mm]	ØH [mm]		
	150	1.0	20	41A	41A 80S I B 8
		1.5	20	41A	41A 80Q 9 B 8
		2.0	20	41A	41A 80Q 9 B 8
		2.5	20	41A	41A 82Q 9 B 8
		3.0	20	41A	41A 80Q 9 B 8
200	1.0	20	41A	41A 80S I B 8	
	2.0	20	41A	41A 80Q 9 B 8	
	3.0	20	41A	41A 80Q 9 B 8	

Bestellbeispiel

- Sägeschärf-scheiben für Holz- und Metallsägen: ISO-Form 1, Durchmesser D: Ø150 mm, Breite T: 6.0 mm, Bohrung H: 20 mm
- Scheibentyp 40A 60 MN 7 V

Spezifikation Scheibentyp → [Seite 4-46](#)

Härteprüfdiamanten

- Produktübersicht 5-2
- Rockwell-Härteprüfverfahren (HRC) 5-3
- Vickers-Härteprüfverfahren (HV) 5-4

Diamant-Messtaster

- Produktübersicht 5-6
- Diamant-Messtaster 5-6



Produktspektrum

Härteprüfdiamanten für Rockwell-Härteprüfverfahren (HRC)
Härteprüfdiamanten für Vickers-Härteprüfverfahren (HV)

→ Seite 5-3

→ Seite 5-4

Vorteile im Überblick

- Verwendung von hochwertigen Diamanten
- Interne und externe Prüfungen
- Mit Zertifikat lieferbar
- Nachschleifbar

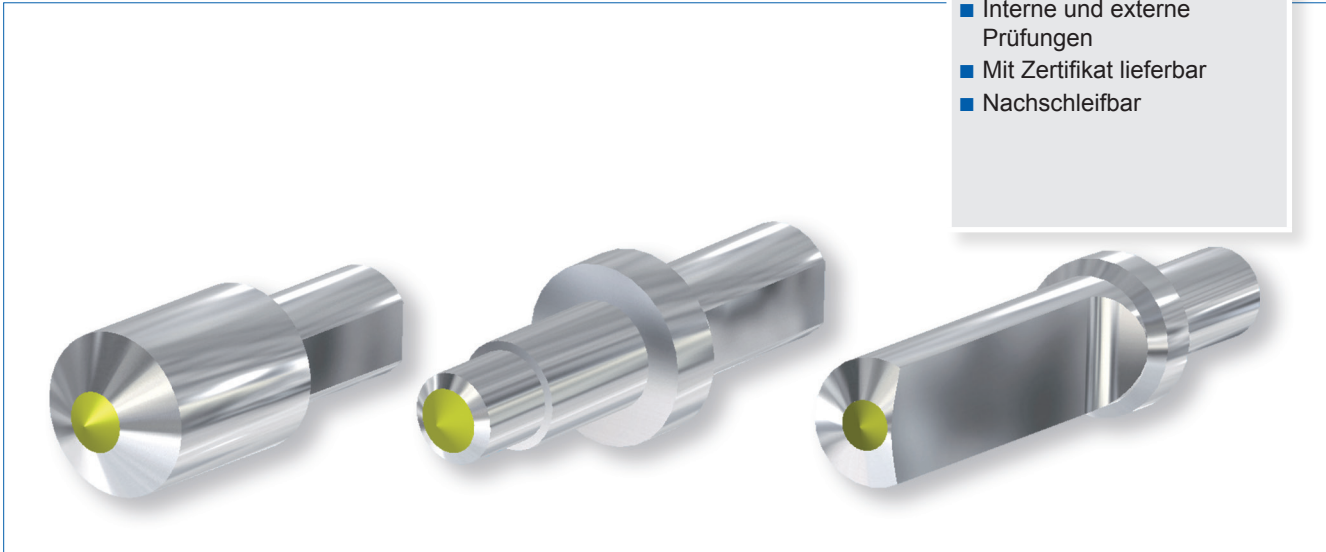

Produktmerkmale

- Geschliffener Naturdiamant in Stahlschaft hart eingelötet
- Diamant- und Schaftform gemäss Zeichnungen auf den Produktseiten → Seite 5-3 bis 5-5

Anwendungsbereiche

- Eindringkörper zum Härteprüfen an harten Werkstoffen
- Zur Einzelprüfung und automatischen Serienprüfung auf Härteprüfgeräten

Einsatzbedingungen

- Diamanten vor Stoss und Schlag schützen
- Betriebsanleitung der Prüfgeräte-Hersteller beachten

Auswahlhilfe

Prüfverfahren	Bezeichnung	Prüfgerät	Typ	Details
Rockwell, Diamantkegel 120°	Original Rockwell	Alle Typen	Nr. 125	→ Seite 5-3
	Testor	Wolpert	Nr. 126	
	UVN	Reicherter	Nr. 127	
	Testor Automat	Testor Automat	Nr. 128	
	Rockwell	Wilson / EMCO	Nr. 132	
Vickers, Diamantpyramide 136°	Testor Automat	Wolpert	Nr. 129	→ Seite 5-4
	Vickers	z. B. Frank	Nr. 130	
	Dia-Testor	Wolpert	Nr. 131	
	Vickers	WPM	Nr. 133	
	Zwick 1	Zwick	Nr. 134	
	Zwick 2	Zwick	Nr. 135	
Einsatz für Briviskop	Briviskop	Nr. 137		



Härteprüfdiamanten für Rockwell-Härteprüfverfahren (HRC)

- Diamantkegel 120°

	Bezeichnung	Typ
	Original Rockwell	Nr. 125
	Testor	Nr. 126
	UVN	Nr. 127
	Testor Automat	Nr. 128
	Rockwell	Nr. 132

Bestellbeispiel

- Härteprüfdiamant Nr.127 UVN



Härteprüfdiamanten für Vickers-Härteprüfverfahren (HV)

■ Diamantpyramide 136°

	Bezeichnung	Typ
	Testor Automat	Nr. 129
	Vickers	Nr. 130
	Dia-Testor	Nr. 131
	Vickers	Nr. 133

Fortsetzung und Bestellbeispiel siehe nächste Seite



	Bezeichnung	Typ
	Zwick 1	Nr. 134
	Zwick 2	Nr. 135
	Einsatz für Briviskop	Nr. 137

Bestellbeispiel

■ Härteprüfdiamant Nr.134 Zwick 1



Diamant-Messtaster

Vorteile im Überblick

- Grosse Messgenauigkeit über lange Zeiträume
- Keine Beschädigung der Werkstückoberfläche

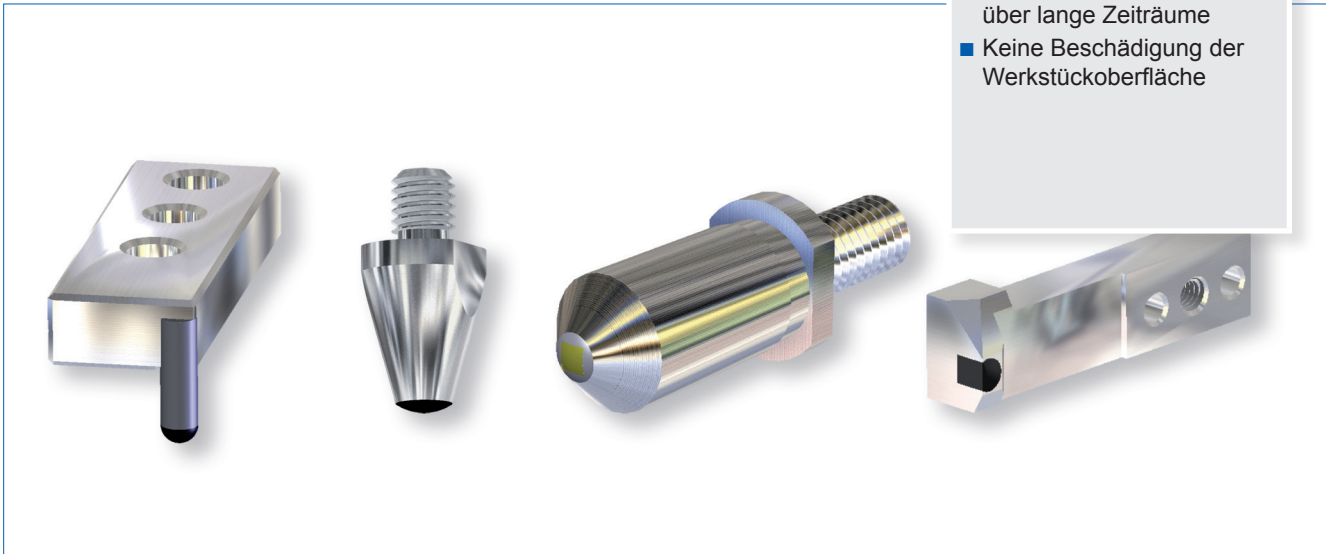

Produktmerkmale

- Verwendung von PKD-Feinkorn (polykristalliner Diamant) oder Naturdiamant.
- Naturdiamant, je nach Verwendung ballig, kegelig oder flach geschliffen, hart eingelötet in rostfreien, antimagnetischen Stahlhalter.

Anwendungsbereiche

- In Verbindung mit Messsteuerungen bei halb- und vollautomatischer Fertigung.

Einsatzbedingungen

- Diamanten vor Stoss und Schlag schützen.
- Auf Sauberkeit der Diamant-Messfläche achten.
- Betriebsanleitung der Messsteuerungs-Hersteller beachten.

Bestellangaben

- Wegen der Typen- und Formenvielfalt bitten wir, der Bestellung eine Zeichnung beizulegen.

Diamant-Poliermittel

- Produktübersicht 6-2
 - Diamant-Polierpaste 6-3
 - Diamant-Polierspray 6-4

Diamant-Handläpper

- Produktübersicht 6-5
 - Diamant-Handläpper 6-5



Produktspektrum

Diamant-Polierpaste
Diamant-Polierspray

→ Seite 6-3
→ Seite 6-4

Anwendungsbereiche

- Automobilindustrie
- Elektronik
- Flugzeugbau
- Werkzeug- und Formenbau
- Walzenbau
- Dentaltechnik
- Medizinaltechnik
- Glas- und Kunststoffindustrie
- Keramikerzeugnisse
- Optik und Werkstoffprüfung



Qualität

Unsere Schleif-, Läpp- und Poliermittel enthalten als schleifaktive Bestandteile Diamantkörnungen natürlicher und synthetischer Herkunft und sind frei von Silikon.

Mit diesen Poliermitteln werden Oberflächen in optischer Qualität erzielt.

Wir verwenden zur Herstellung unserer Produkte nur gesundes Originalmaterial und keine Diamanten aus Rückgewinnungen.

Diamant-Körnungen

Naturdiamant

Überwiegend blockige, sehr kräftige Partikel mit sehr vielen kurzen, aber scharfen Schneiden. Die Kornform und die Kristallstruktur ermöglichen einen hohen Spanabtrag und gleichmässige Rautiefen auf den Werkstückoberflächen.

Synthetischer Diamant

Blockige bis splittrige Partikel, die Kornform und die Kristallstruktur ermöglichen einen hohen Spanabtrag. Das Oberflächenbild ist häufig unregelmässiger als bei der Verwendung von Naturdiamant.

Bindungen

Typ U (Diamant-Polierpaste)

- Mischbar mit Öl, Wasser und Alkohol, sehr gute Filmbildung.
- Reinigung von Werkzeug und Werkstück mit Wasser.

Typ A (Diamant-Polierspray)

- Mischbar mit Alkohol und Wasser in jedem Verhältnis.
- Leichte Reinigung von Werkzeug und Werkstück mit Wasser.

Typ O (Diamant-Polierspray)

- Mischbar mit Öl und Wasser, sehr gute Filmbildung.
- Reinigung von Werkzeug und Werkstück nur mit Lösungsmitteln.

Konzentrationen

Typ S (Diamant-Polierpaste)

- Sehr hohe Konzentration
- Anwendung: Hartmetall, Keramik, Verbundwerkstoffe, metallografische Werkstoffprüfung



Diamant-Polierpaste

- Synthetischer Diamant
- Inhalt: 5 g
- Bindung: Typ U
- Konzentration: Typ S

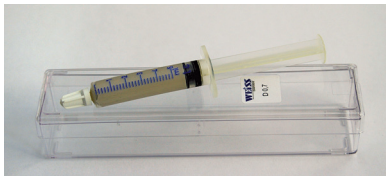

Körnung [µm]	Lieferzeit		Typ
	Auf Lager ¹⁾	ca. 2-3 KW	
sehr fein 0.25	–	○	D 0.25
0.70	✓	–	D 0.7
1.00	–	○	D 1
1.50	–	○	D 1.5
2.00	–	○	D 2
3.00	✓	–	D 3
5.00	–	○	D 5
7.00	✓	–	D 7
9.00	–	○	D 9
10.00	–	○	D 10
12.00	–	○	D 12
15.00	✓	–	D 15
20.00	–	○	D 20
25.00	–	○	D 25
30.00	✓	–	D 30
40.00	–	○	D 40
grob 50.00	✓	–	D 50

Bestellbeispiel

- Diamant-Polierpaste D 0.7

¹⁾ Zwischenverkauf vorbehalten



Diamant-Polierspray

Diamant-Poliermittel

Diamant-Polierspray

- 165-ml-Sprühdose aus Weissblech mit einem Sprühkopf zur Feindosierung.
- Treibmittel ohne FCKW.
- Bindung Typ A: niedrige Viskosität für den Laborbereich
- Bindung Typ O: für den Werkzeugbau



Körnung [µm]	Lieferzeit		Typ
	Auf Lager ¹⁾	ca. 2–3 KW	
sehr fein 0.25	–	○	D 0.25
1.00	–	○	D 1
3.00	✓	–	D 3
6.00	✓	–	D 6
9.00	✓	–	D 9
12.00	–	○	D 12
grob 15.00	–	○	D 15

Bestellbeispiel

- Diamant-Polierspray D 1, Bindung Typ A

¹⁾ Zwischenverkauf vorbehalten



Anwendungsbereich

- Nachläppen von Hartmetall-Schneidwerkzeugen

Vorteile im Überblick

- Gute Abtragsleistung
- Erhöhte Zerspanungsleistung durch scharfe Schneidkanten

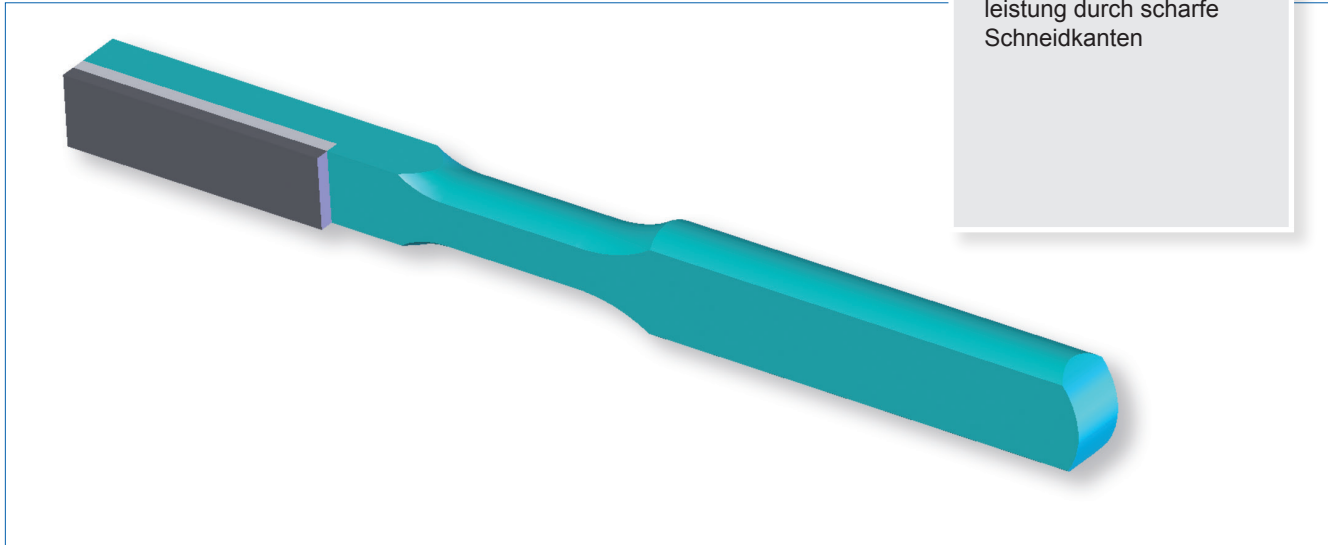

Merkmale

Bindungen

- Diamantkorn in
 - Typ K: Kunststoff-Bindung auf Leichtmetallträger
 - Typ M: Metall-Bindung auf Leichtmetall bzw. Stahlträger (auf Anfrage)
 - Typ G: galvanische Bindung auf Leichtmetall bzw. Stahlträger (auf Anfrage)

Abmessung

- Abmessungen der diamantbelegten Fläche:
10 mm x 40 mm

Körnung (Angabe in μm)

- D15 (fein)
- D25
- D46
- D64
- D91
- D126 (grob)

Einsatzbedingungen

- Geringer Anpressdruck erhöht die Lebensdauer
- Diamantbelag gelegentlich mit Petroleum reinigen, eventuell auch mit Abziehstein (nur bei K- und M-Bindung)

Bestellbeispiel

- Handläpper D46 K



Diamant-Feilen

■ Produktübersicht	7-2
■ Diamant-Handfeilen	7-3
■ Diamant-Nadelfeilen	7-3
■ Diamant-Diprofilfeilen	7-4
■ Diamant-Riffelfeilen	7-5
■ Diamant-Kontaktfeilen	7-6
■ Diamant-Maschinenfeilen	7-7



Produktspektrum

Handfeilen

Diamant-Nadelfeilen

→ Seite 7-3

Diamant-Diprofilfeilen

→ Seite 7-4

Diamant-Riffelfeilen

→ Seite 7-5

Diamant-Kontaktfeilen

→ Seite 7-6

Maschinenfeilen

Diamant-Maschinenfeilen

→ Seite 7-7

Vorteile im Überblick

- Gute Abtragsleistung
- Lange Lebensdauer



Produktmerkmale

- Einschichtig, galvanisch gebundenes Diamantkorn auf Stahlträger

Anwendungsbereiche

- Hand- und Maschinenfeilarbeiten an harten Werkstoffen.









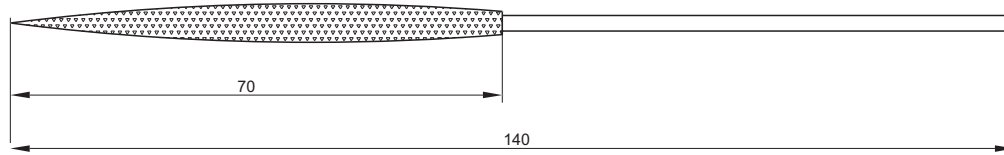

Einsatzbedingungen

- Geringer Anpressdruck erhöht die Lebensdauer.
- Scharfe Kanten am Werkstück erst mit bereits stumpfer Feile brechen.



Diamant-Nadelfeilen



	Form	Querschnitt [mm]	Typ
	Rund	Ø3-1	DH1
	Halbrund	5 x 2	DH2
	Flachstumpf	5.5 x 1.5	DH3
	Dreikant	3.5	DH4
	Vierkant	3 x 3	DH5
	Vogelzunge	5 x 2.5	DH6
	Messer	5.2 x 1.5	DH7
	Schwert	5.5 x 2.5	DH8
	Barett	5.5 x 2	DH9
	Flachstumpf mit runden Kanten	5.5 x 1.5	DH10
	Flachspitz	5 x 1.5	DH11

Bestellinformationen

Lieferbare Körnungen¹⁾

D91	D126	D151
fein		grob

¹⁾ D126 und D151 ab Lager lieferbar, andere Körnungen auf Anfrage

Die 5 gebräuchlichsten Diamant-Nadelfeilen DH1 bis DH5 sind als Sortiment in einer praktischen Kunststoffverpackung erhältlich.

Bestellbeispiel

■ Diamant-Nadelfeile DH2 Halbrund, D126



Diamant-Diprofilfeilen

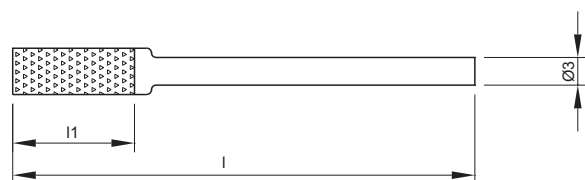

	Form	Abmessungen			Typ
		Querschnitt [mm]	l [mm]	l1 [mm]	
	Rund	1	50	15	DR1
		2	50	15	DR2
		3	50	15	DR3
		4	50	15	DR4
		2	60	25	DR5
		3	60	25	DR6
		4	60	25	DR7
	Flach	2 x 1	50	15	DR21
		3 x 1	50	15	DR22
		4 x 1	50	15	DR23
		5 x 2	50	15	DR24
		5 x 2	60	25	DR25
	Vierkant	1.5	50	15	DR31
		2	50	15	DR32
		3	50	15	DR33
		4	50	15	DR34
		5	50	15	DR35
	Messer	5	60	25	DR37
		4 x 1	50	15	DR41
		6 x 2	50	15	DR42
	Dreikant	6 x 2	60	25	DR43
		2	50	15	DR51
		3.5	50	15	DR52
	Dreikant	4.5	50	15	DR53
		3.5	60	25	DR54
		4.5	60	25	DR55
		2 x 1	50	15	DR61
	Vogelzunge	3.5 x 2	50	15	DR62
		6 x 3	50	15	DR64
		3.5 x 2	60	25	DR65
		5 x 2.5	60	25	DR66
		6 x 3	60	25	DR67
	Flach einseitig	2 x 1	50	15	DR71
		3 x 1	50	15	DR72
		4 x 1	50	15	DR73
		5 x 2	50	15	DR74
		5 x 2	60	25	DR75
	Flach zweiseitig	2 x 1	50	15	DR81
		3 x 1	50	15	DR82
		4 x 1	50	15	DR83
		5 x 2	50	15	DR84
		5 x 2	60	25	DR85
	Kanten	0.5 x 4	50	15	DR91
		0.75 x 4	50	15	DR92
		1 x 4	50	15	DR93
		1 x 4	60	25	DR94

Bestellinformationen

Lieferbare Körnungen¹⁾

D91	D126	D151
fein		grob

¹⁾ Auf Anfrage, bitte Wunschtermin für die Lieferung angeben

Bestellbeispiel

■ Diamant-Diprofilfeile DR55 Dreikant, D126



Diamant-Riffelfeilen

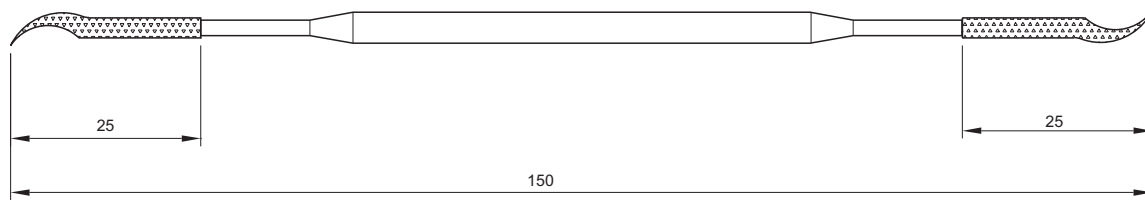

	Form	Querschnitt [mm]	Typ
	Vogelzunge gerade	3.5 x 2	DF1
	Vogelzunge gebogen	3.5 x 2	DF2
	Flach	3 x 1.5	DF3
	Vierkant	2	DF4
	Dreikant	2 x 2	DF5

Bestellinformationen

Lieferbare Körnungen ¹⁾		
D91	D126	D151
fein		grob

¹⁾ D126 und D151 teilweise ab Lager lieferbar, Lieferzeit und andere Körnungen auf Anfrage

Bestellbeispiel

■ Diamant-Riffelfeile DF4 Vierkant, D126



Diamant-Kontaktfeilen

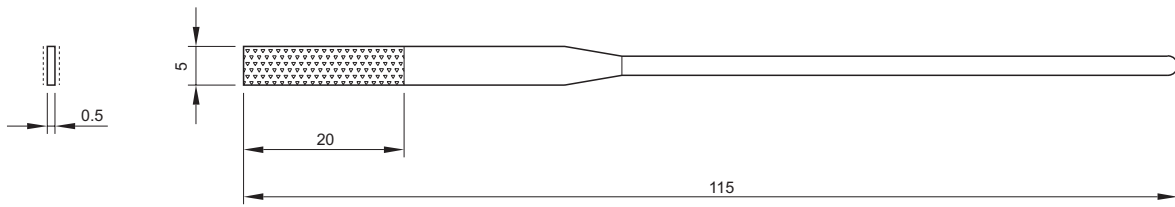

Bestellinformationen

Lieferbare Körnungen ¹⁾		
D91	D126	D151
fein	→	grob

Bestellbeispiel

■ Diamant-Kontaktfeile, D151



Diamant-Maschinenfeilen

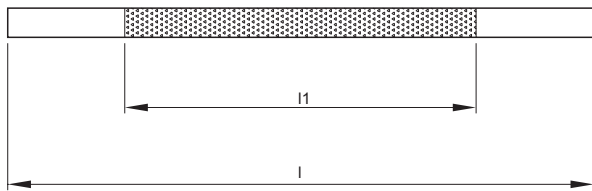

	Form	Abmessungen			Typ
		Querschnitt [mm]	l [mm]	l1 [mm]	
	Rund	2.0	100	60	DM1
		3.5	125	80	DM2
		5.0	125	80	DM3
		6.5	150	80	DM4
		10.0	200	120	DM5
	Halbrund	5.0 x 2.5	150	80	DM14
		8.0 x 4.0	150	80	DM15
		10.5 x 5.0	200	120	DM16
	Flach	2.0 x 1.5	100	60	DM21
		4.0 x 2.0	125	80	DM22
		5.0 x 2.0	125	80	DM23
		9.0 x 3.2	150	80	DM24
		11.0 x 4.0	200	120	DM25
	Dreikant	3.0	125	80	DM32
		6.0	150	80	DM34
		8.0	150	80	DM35
		10.0	200	120	DM36
	Vierkant	2.0	100	60	DM41
		3.0	125	80	DM42
		4.0	150	80	DM43
		5.0	125	80	DM44
		8.0	150	80	DM45
		10.0	200	120	DM46

Bestellinformationen

Lieferbare Körnungen¹⁾

D91	D126	D151
fein	grob	

¹⁾ D126 und D151 teilweise ab Lager lieferbar, Lieferzeit und andere Körnungen auf Anfrage

Bestellbeispiel

■ Diamant-Maschinenfeile DM25 Flach, D126



Übersicht über die Dienstleistungen der WEISS AG

- Sonderwerkzeuge 8-2
- Laserbearbeitung 8-2
- Hartlöten mittels Induktion 8-3
- Drahterodieren 8-3
- Nachschleifservice 8-3
- Beratung vor Ort 8-3



Sonderwerkzeuge

Eine unserer grossen Stärken ist die Herstellung von Diamant- und CBN-Sonderwerkzeugen.

Wir fertigen nach Skizzen, Zeichnungen, Musterwerkzeugen, Teilwerkzeugen oder einfach nach telefonischer Rücksprache Sonderwerkzeuge im Bereich Drehen, Fräsen, Abrichten und Schleifen.

Bei Bedarf besuchen wir Sie vor Ort, oder Sie schicken uns die Daten per Post, Fax oder Mail. Bei weiteren Angaben wie Maschinenkapazitäten, zu bearbeitendes Material, Kühlmöglichkeiten, Oberflächengüten usw. kann die Entwicklungszeit der Werkzeuge stark verkürzt werden.

Nach entsprechender Freigabe der Zeichnung durch den Kunden werden die Werkzeuge produziert und ausgeliefert. Eine entsprechende Rückfrage nach erfolgtem Einsatz hilft uns, Verbesserungsmassnahmen einzuleiten und uns somit stetig zu verbessern.

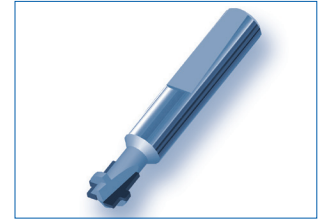
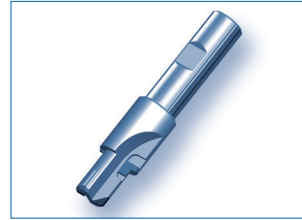
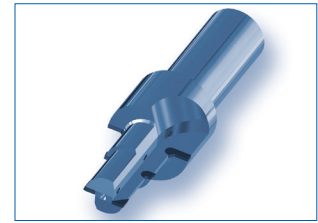
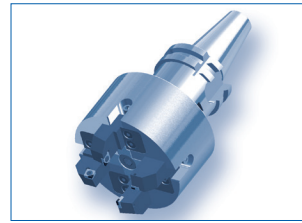

Laserbearbeitung

Mit der neusten Lasertechnologie können bei maximaler Prozesssicherheit auch feinste Konturen und Kavitäten erzeugt werden – und das fast ohne Werkzeugkosten.

Im Vergleich zum Erodierverfahren erfolgt die direkte Bearbeitung auch schwer zerspanbarer Werkstoffe wie Keramik oder Hartmetall ohne Elektrodenfertigung. Ein wesentlicher Vorteil, der nicht nur Fertigungszeiten und -kosten spart, sondern gleichzeitig auch die Umwelt schont.

Vorteile der Lasertechnologie

- Direkte Bearbeitung des Werkstücks ohne Elektrodenfertigung
- Wesentlich kürzere Herstellzeiten für filigrane Werkstücke
- Reproduzierbare Fertigung – problemlose Datenübertragung mit der neuen LaserSoft 3D-Software
- Maximale Prozesssicherheit ohne Werkzeugkosten
- Bearbeitung senkrechter Wände

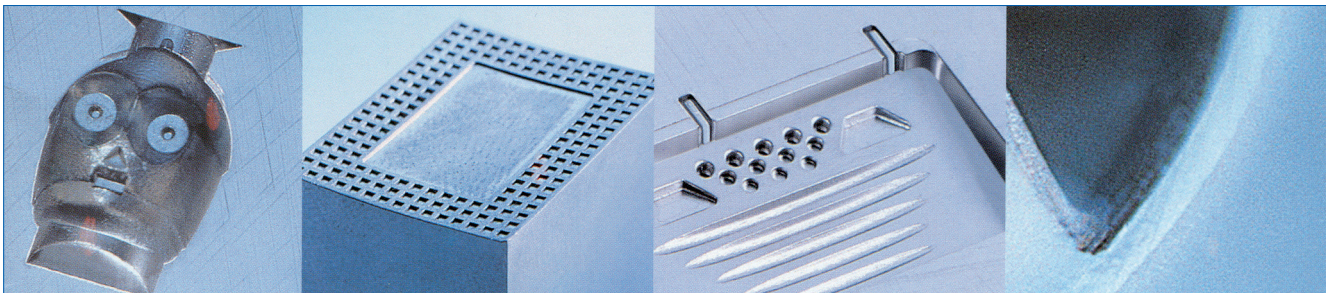

Anwendungen

- Technische Präzisionsformen
- Medizinaltechnik
- Elektronik und Halbleiterformen
- Mikrotechnologie
- Reliefs
- Stempel
- Gravuren/Tiefgravuren
- Oberflächenstrukturen
- Spanleitstufen in HM- und Diamantwerkzeugen
- CVD-Diamant-Bearbeitung
- MKD-Bearbeitung

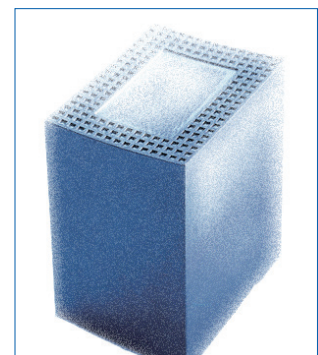
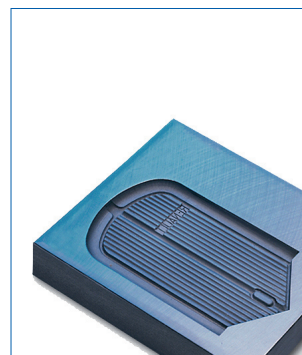



Hartlöten mittels Induktion

In der Löttechnik sind homogene Erwärmungen an der Verbindungsstelle zur Vermeidung von Eigenspannungen gefordert. Durch den Einsatz von Induktion wird das Werkstück von innen heraus gleichmässig erwärmt und erfüllt somit obige Notwendigkeit. Des Weiteren garantiert die Induktionserwärmung reproduzierbare und mitarbeiterunabhängige Lötungen. Wir bieten Ihnen einen zuverlässigen und prompten Hartlöt-service.

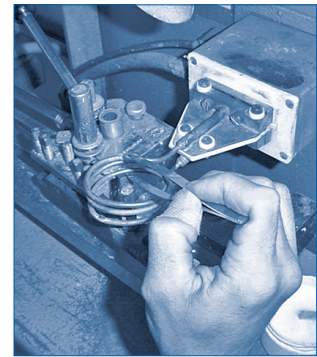
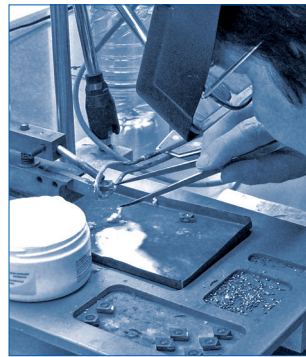

Drahterodieren

Mittels Drahterodiermaschine mit fünf CNC-gesteuerten Achsen können die verschiedensten Formen in Schneiden aus PKD und anderen Hartwerkstoffen in fliegender Aufspannung hergestellt werden. Das Lademagazin für bis zu zwölf Werkstücke garantiert dabei eine hohe Laufzeit und somit geringe Einricht- und Stückkosten. Eine hohe Prozesssicherheit und Leistungsfähigkeit dieser Maschinen, insbesondere bei Werkzeugen mit Profilen und komplexen Geometrien gewährleisten unseren Kunden eine hohe Qualitäts- und Liefertreue.



Nachschleifservice

Bei der WEISS AG bekommen Sie den professionellen Nachschleifservice für Ihre Werkzeuge.

Bei Bedarf können beschädigte Werkzeuge neu aufbereitet oder Geometriekorrekturen an bestehenden CBN- und Diamantwerkzeugen vorgenommen werden. Dies gilt nicht nur für von uns produzierte Werkzeuge, sondern auch für Fremdprodukte.

Mit unserem Nachschleifservice haben Sie die Möglichkeit, Ihre Werkzeuge so nachschleifen zu lassen, dass sie dieselben Eigenschaften wie neue Werkzeuge aufweisen. Dieser Service ist bei Bedarf je nach Werkzeugtyp und Aufwand innerhalb 24 Std. möglich.

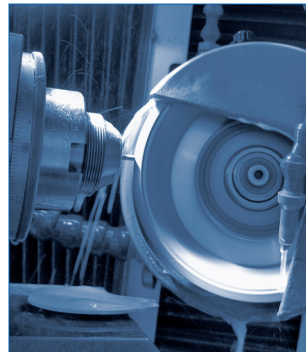

Beratung vor Ort

Kompetente Fachberater im Innen- und Aussendienst stehen Ihnen bei all Ihren Fertigungs- und Bearbeitungsproblemen mit Rat und Tat zur Seite.

Sie erreichen Ihren persönlichen Berater per Telefon während der Arbeitszeit, per Fax oder E-Mail. Er berät Sie gerne in allen Fertigungs- oder Bearbeitungsproblemen, nimmt Ihre Bestellungen entgegen und sorgt für eine zuverlässige Auftragsabwicklung.

Ausserdem besucht Sie der Fachberater im Aussendienst gerne vor Ort und berät Sie über Marktentwicklungen, Werkzeugneuheiten und neuste Anwendungen. Als Fertigungsspezialist ist er Ihr Ansprechpartner für individuelle Fertigungs- oder Bearbeitungsprobleme und erarbeitet mit Ihnen die entsprechende Lösung.

Fragen Sie uns an und testen Sie uns!



Bestellvorgang

- Auf den Produktseiten stehen Ihnen immer Bestellinformationen und/oder Bestellbeispiele zur Verfügung.
- Sie werden schrittweise durch die Produkte geführt, um zielsicher die richtige Auswahl zu treffen.
- Für Ihre Bestellungen bitten wir Sie, alle in den Bestellbeispielen gemachten Angaben an uns weiterzugeben.
- Wenn Sie zu den Angaben Fragen haben, stehen wir Ihnen selbstverständlich gerne zur Verfügung.
- Ihre Bestellungen können Sie per E-Mail, telefonisch oder per Post übermitteln. Die Kontaktdaten finden Sie unten auf dieser Seite.

ISO-Schneidplatten mit BORAPACT-Schneiden
Anwendung Innen | Schneidenausführung Einweg

1 ISO-Schneidplatten mit BORAPACT-Schneiden

■ Anwendung Innen
■ Schneidenausführung Einweg
Typ CCMW

α	Abmessungen				Typ
	l1 [mm]	l [mm]	s [mm]	r [mm]	
7°	2.0	6.45	2.38	0.2	CCMW 06 02 02 T-E B0..
	2.0	6.45	2.38	0.4	CCMW 06 02 04 T-E B0..
	2.5	9.65	3.97	0.2	CCMW 09 T3 02 T-E B0..
	2.5	9.65	3.97	0.4	CCMW 09 T3 04 T-E B0..

Typ DCMW

α	Abmessungen				Typ
	l1 [mm]	l [mm]	s [mm]	r [mm]	
7°	2.0	7.75	2.38	0.2	DCMW 07 02 02 T-E B0..
	2.0	7.75	2.38	0.4	DCMW 07 02 04 T-E B0..
	2.5	11.6	3.97	0.2	DCMW 11 T3 02 T-E B0..
	2.5	11.6	3.97	0.4	DCMW 11 T3 04 T-E B0..

Typ TPUN

α	Abmessungen				Typ
	l1 [mm]	l [mm]	s [mm]	r [mm]	
11°	2.5	16.5	3.18	0.4	TPUN 16 03 04 T-E B0..
	2.5	16.5	3.18	0.8	TPUN 16 03 08 T-E B0..

Typ VCMW

α	Abmessungen				Typ
	l1 [mm]	l [mm]	s [mm]	r [mm]	
7°	2.5	11.1	3.18	0.2	VCMW 11 03 02 T-E B0..
	2.5	11.1	3.18	0.4	VCMW 11 03 04 T-E B0..
	3.0	16.6	4.76	0.2	VCMW 16 04 02 T-E B0..
	3.0	16.6	4.76	0.8	VCMW 16 04 04 T-E B0..

2 Bestellinformationen

Bestell-Code	BORAPACT						
	B010	B020	B040	B050	B060	B070	B080
Verfügbarkeit	✓	○	○	○	○	○	○
Weitere Infos siehe Seite	1-xx						

✓ Auf Lager ○ Auf Anfrage, bitte Wunschtermin für die Lieferung angeben

Bestellbeispiel für:
Typ: DCMW 07 02 02 T-E B0..
Ausführung B020
= DCMW 07 02 02 T-E B020
= l1 = 2.0 mm
= r = 1.1 mm (Wunschtermin)

WEISS
DIAMANT- UND CBN-WERKZEUGE

© WEISS AG – Technische Änderungen vorbehalten 1-11

Kontaktdaten

- Sie können uns Montag bis Freitag jeweils von 7.30 Uhr bis 12 Uhr und 13.30 Uhr bis 17.00 Uhr telefonisch erreichen.
- Wir stehen Ihnen per Telefon und E-Mail zur Verfügung.
- Nach Terminvereinbarung besuchen wir Sie auch gerne vor Ort.
- Im Internet können Sie sich zusätzlich über unsere Produkte und Dienstleistungen informieren.

WEISS AG

Diamant- und CBN-Werkzeuge

Platz 229
CH-9428 Walzenhausen

Tel. +41 71 886 49 00
Mail info@weiss-diamant.com
Internet www.weiss-diamant.com

Impressum

Fachkatalog

Diamant- und CBN-Werkzeuge

Herausgeber:

WEISS AG

Diamant- und CBN-Werkzeuge

Platz 229

CH-9428 Walzenhausen

info@weiss-diamant.com

www.weiss-diamant.com

Die ausgewählte Produktpalette dieses Kataloges stellt einen Querschnitt des Lieferprogramms dar. Was nicht lagerhaltig geführt werden kann oder zur Bestellzeit nicht lagerhaltig ist, wird im Bedarfsfall schnellstmöglich hergestellt und geliefert.

Technische Änderungen vorbehalten. Haftung für Druckfehler und -mängel sowie fehlerhafte technische Angaben und Abbildungen wird ausgeschlossen.

Nachdruck – auch auszugsweise – nur mit schriftlicher Genehmigung des Herausgebers.

Die Preise und die Geschäftsbedingungen entnehmen Sie aus der zur Zeit gültigen Preisliste.



Ihr Partner für Diamant- und CBN-Werkzeuge

Chronik

- 1969** gründete die Ph. Oskar Weiss KG, Stuttgart die WEISS AG zur besseren Bearbeitung der EFTA-Freizone und eines Teils des ehemaligen Ostblocks.
- 1990** vom damaligen Inhaber SlipNaxos, durch den längjährigen Geschäftsführer übernommen.
- 1993** Übernahme der Ph. Oskar Weiss GmbH als wichtige Verkaufsorganisation für den deutschen Markt.
- 1997** Verkauf der WEISS AG an Dr. iur. H. Altherr.
- 2007** Verkauf der Ph. Oskar Weiss GmbH an die Firma Comet Schleifscheiben GmbH
- 2009** 40-jähriges Jubiläum
- 2019** 50-jähriges Jubiläum



Unternehmensphilosophie

- Zuverlässigkeit auf jeder Ebene
- Technische Beratung bei Fertigungsproblemen
- Massgeschneiderte Lösungsvorschläge
- Qualitativ hochstehende Werkzeuge zu einem fairen Preis
- Liefertreue

Stärken

- Grosse Flexibilität, hohe Lieferbereitschaft
- Kurze Entscheidungswege, daher kurze Reaktionszeiten
- Wir halten, was wir versprechen:
 - Qualität
 - Termin
 - Preis





Unternehmenspolitik

Wir produzieren Diamant- und CBN-Werkzeuge für sämtliche Anwendungen im Metall- und Kunststoffbereich.



Oberstes Ziel ist eine nachhaltige Entwicklung des Unternehmens. Nachhaltig heisst für uns:

- Wir streben langfristige Kundenbeziehungen an. Dazu beraten wir unsere Kunden kompetent, liefern Ideen und sind bereit, mit ihnen Neues zu entwickeln. Eine termingerechte und qualitativ hochstehende Produktion ist selbstverständlich. Die Preise sind angemessen und fair
- Unsere Mitarbeitenden bilden den Kern des Unternehmens. Wir setzen auch hier auf langjährige Beziehungen, sorgen für „gesunde“ Arbeitsbedingungen und investieren zielgerichtet in die Aus- und Weiterbildung
- Unsere Lieferanten behandeln wir wie unsere Kunden
- Bei all unseren Tätigkeiten schonen wir die Umwelt und verbrauchen ein Minimum an Ressourcen



Zertifizierung

Zertifizierungsablauf der WEISS AG

1997		
1. Zertifizierung		ISO 9002
2000		
1. Wiederholaudit		ISO 9001
2003		
2. Wiederholaudit (Umbau in prozessorientiertes QM)		ISO 9001:2000
2006		
3. Wiederholaudit		ISO 9001:2000
2009		
4. Wiederholaudit		ISO 9001:2008
2012		
5. Wiederholaudit		ISO 9001:2008
2015		
6. Wiederholaudit		ISO 9001:2008
2018		
7. Rezertifizierungsaudit		ISO 9001:2015



Zertifikat

Die SQS bescheinigt hiermit, dass nachstehend genanntes Unternehmen über ein Managementsystem verfügt, das den Anforderungen der aufgeführten normativen Grundlage entspricht.

WEISS AG
Platz 229
9428 Walzenhausen
Schweiz

Geltungsbereich
Ganzes Unternehmen

Tätigkeitsgebiet
Diamant und CBN-Werkzeuge

Normative Grundlage
ISO 9001:2015 Qualitätsmanagementsystem

Scope(s) 17 Gültigkeit 08.11.2018 – 19.06.2021 Reg.-Nr. 13267
Version 08.11.2018

 X. Edelmann, Präsident SQS

 F. Müller, CEO SQS

sqz.ch

Schweizerische Vereinigung für
Qualitäts- und Management-Systeme SQS
Birmstrasse 103, 3052 Zollikofen, Schweiz

Swiss Made

Partner of
IQNet