

X-CYCLONE® CE-XSC Series



Operating and Maintenance Instructions

Models CE10-1-XSC, CE10-2-XSC, CE10-3-XSC, CE17-1-XSC, CE17-2-XSC,
CE17-3-XSC, CE25-1-XSC, CE25-2-XSC, CE25-3-XSC



INNOVATION BW
Award Winner
Innovation Award Baden-Württemberg
Dr.-Rudolf-Eberle-Preis













Order No.

As of August 2023

Manufacturer
Rentschler REVEN GmbH
Ludwigstrasse 16–18
74372 Sersheim · Germany

Phone: +49 7042 373-0
www.reven.de

	General Description	3
	Safety Notices	4
	WARNING	4
	Installation of the Equipment	5
	Detailed Description of the Device and its Functions	10
	Technical Data	16
	Electrical Connection	17
	Cleaning and Maintenance	22
	Spare Parts List	35
	Accessories	40
	Manufacturer's Declaration	41



ATTENTION:

Read the manual completely before setting up the device and before commencing any cleaning or maintenance work!

Manufacturer



General Description

The high-performance air cleaner is designed as a multi-stage system and delivered ready for connection. The fan is integrated into the device. The maintenance door is fitted with quick-release fasteners and a safety switch. When the door is opened, the safety switch cuts off all poles of the supply voltage and thus ensures safe working on the device. The stainless steel housing (material no. 1.4016) with a lacquer finish in RAL 7035 is stable and torsion-resistant with smooth inner surfaces. The bottom part is designed as an oil- and watertight collecting pan. Patented X-CYCLONE® Aerosol Separators ensure the mechanical separation of aerosols and liquid particles, electrostatic precipitators provide for the electrostatic separation of these particles. Therefore, the removal of even smallest droplets is guaranteed. The device is designed to prevent uncontrolled growth of micro-organisms if the specified cleaning and maintenance intervals are observed (see page 22).

! The X-CYCLONE® Aerosol Separators, agglomerators and electrostatic precipitators can be cleaned and reused – no throw-away filters!

The **flame-arresting capability** of the separators was tested in accordance with DIN EN 16282 and DIN 18869-5.

In the standard version, the devices are fitted with an agglomerator and an X-CYCLONE® Aerosol Separator in the pre-stage in addition to an electrostatic filter stage. The electrostatic stage includes one, two or three precipitators in series - referred to as simplex, duplex or triplex system. A sound-absorber top unit is included in the scope of delivery.

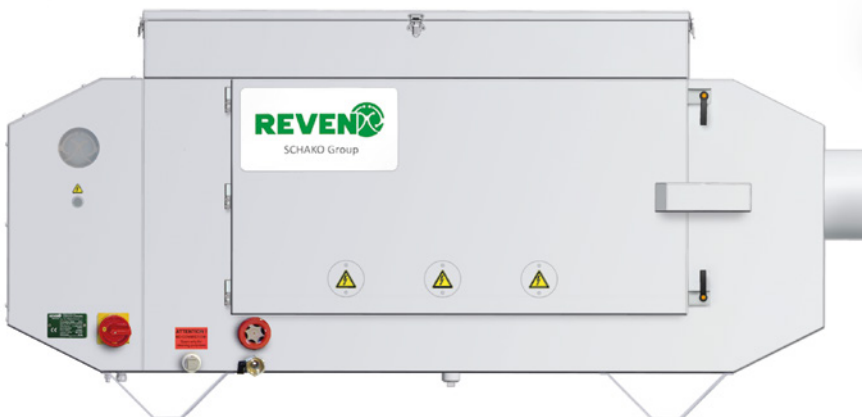

Fig.: X-CYCLONE® CE-XSC with sound absorber (standard version)

The air cleaners of the X-CYCLONE® CE-XSC series have been developed, designed and manufactured in compliance with EC Directives.

Material X-CYCLONE® CE-XSC series

Housing	stainless steel 1.4016 with a lacquer finish in RAL 7035
Separator	
Frame	stainless steel 1.4016
Profiles	aluminium
Precipitator	
Frame	stainless steel 1.4016
Plates	aluminium
Agglomerator	stainless steel 1.4301

Special versions

entirely made of stainless steel (material no. 1.4301) are available on request!

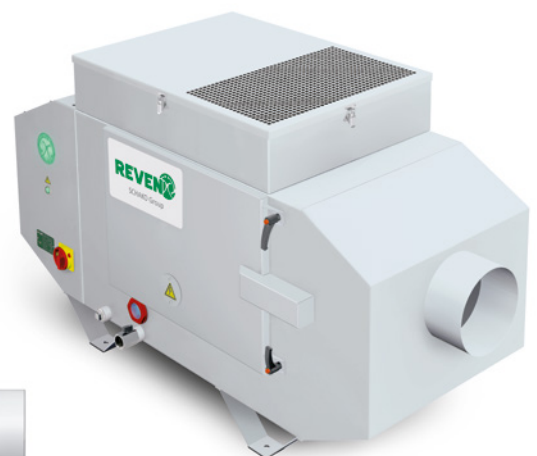



Safety Notices



WARNING



Use of the devices in potentially explosive environments

Our separators are delivered without explosion protection. This means that no vapours, gases, or mists that are themselves explosive or might form *explosive media* inside the devices may be extracted.

Extraction of media with a low point of ignition

The steady increase in the use of liquids with a low ignition point in modern machine tools produces a *generally increased risk of fire and explosion in the material processing sector*. In case of doubt, contact a competent specialised provider of fire protection consultancy services and equipment.

Use of the devices in combination with toxic substances

Gaseous substances cannot be separated. For this reason, REVEN® equipment must not be used *if toxic substances have to be extracted in inadmissibly high concentrations*

! ATTENTION:

Never open the maintenance door when the device is running. Never switch the device on when the maintenance door is open.

There is a high risk of accident in both cases!

After switching off the device, wait at least 10 minutes to allow the high voltage to dissipate. Do not open the maintenance door before.

The recirculation of cleaned air in connection with the handling of particularly carcinogenic materials is prohibited in accordance with Art. 15a of the German regulation on the handling of hazardous materials GefStoffV. These substances are:

- 6-amino-2-ethoxynaphthalene
- 4-aminobiphenyl and its salts
- Asbestos
- Benzidine and its salts
- Bis(chlormethyl)ether
- Cadmium chloride (in respirable condition)
- Chloromethyl methyl ether
- Dimethylcarbamoylechloride
- Hexamethyl phosphoric acid triamide
- 2-naphtylamine and its salts
- 4-nitrodiphenyl
- 1,3-propane sultone
- N-nitrosamine compounds
- Tetranitromethane
- 1,2,3-trichloropropane

! *In these cases, the air extracted by the X-CYCLONE® Air Cleaners must not be recirculated, i.e. no cleaned air may be returned into areas where people congregate!*



General notices

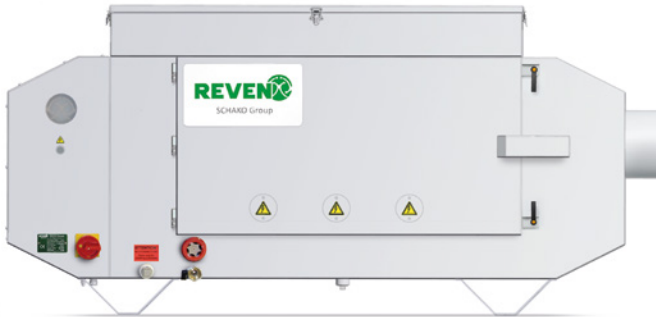

- Set up the X-CYCLONE® CE-XSC Air Cleaner **! in a perfectly horizontal position.**
- When putting up the device make sure that the maintenance side of the device is accessible to connect a drain pipe to the one-inch socket.
- The oil- or emulsion-return piping must be installed separately. **! This means that the drainage openings must not be connected to each other, i.e. must not be short-circuited!**
- You can fix the X-CYCLONE® CE-XSC using the installation supports underneath the liquid-collecting pan.
- Make sure that the maintenance door can be opened up by 90° at least.
- The X-CYCLONE® CE-XSC Air Cleaner must be connected to the local equipotential bonding system.
- If you desire special fastening devices such as suspensions or mounting frames, please specify them in your inquiry.

! ATTENTION:

When putting the device into operation for the first time or after a longer downtime, observe the following notes: **The device might indicate a malfunction due to flashovers in the precipitators caused by dust deposits.** In this case, switch the device off and on again. If the device still indicates a malfunction repeat this procedure several times.

Mounting/installation of the device

Fastening points for suspension lugs are provided inside the device to facilitate transport and installation.

! To fit the suspension lugs, remove the exhaust lid and the sound-absorbing mat.

Suspension lugs can be ordered optionally.

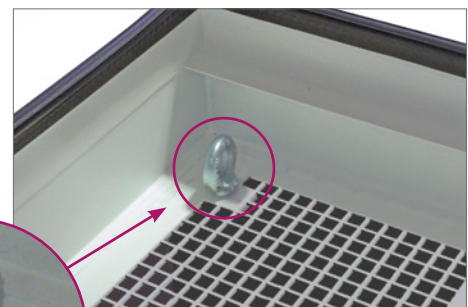

Fig.: Suspension lugs are optionally available.



Installation of the Equipment II

Fixing the device

1. Choose the place of installation.
Consider the load-bearing capacity of the processing machine,
! *when installing the device directly on top of it.*
2. If you install the device directly on top of the machine, line up the hole pattern and drill accordingly.
! *Pay attention to any rails or built-in units underneath!*
3. Fasten the X-CYCLONE® CE-XSC with M10 machine screws.

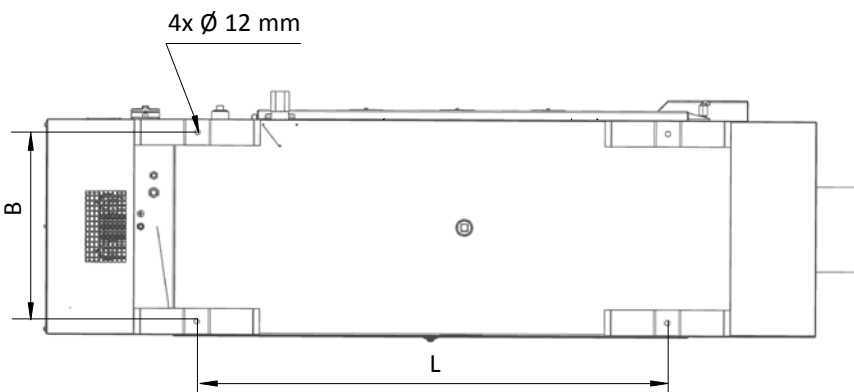
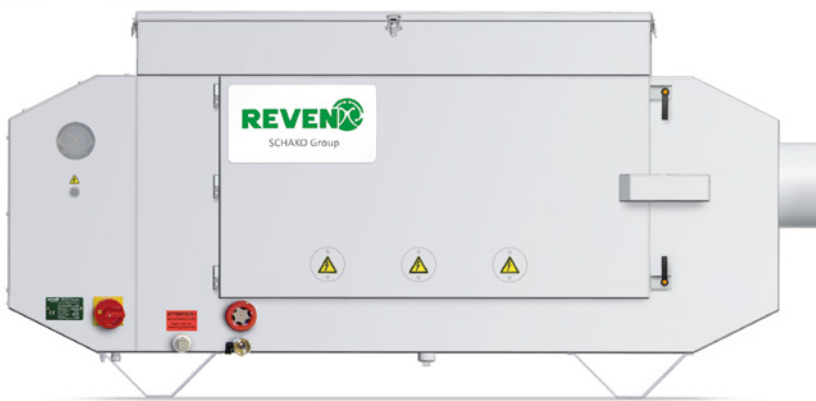
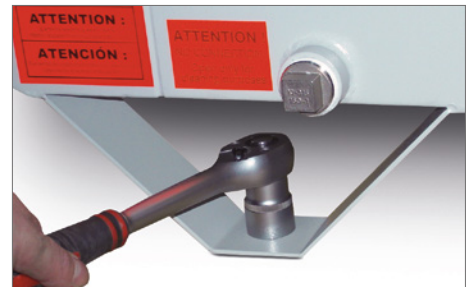
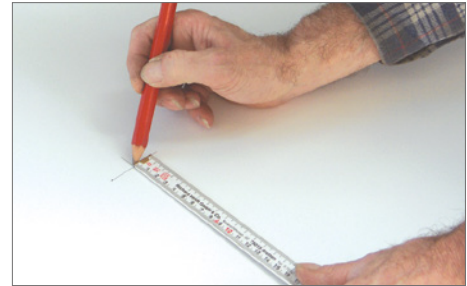

Fig.: Spacing of the fastening holes

X-CYCLONE®	Width in mm	Length in mm
CE10-1-XSC	475	635
CE10-2-XSC	475	840
CE10-3-XSC	475	1055
CE17-1-XSC	440	675
CE17-2-XSC	440	890
CE17-3-XSC	440	1100
CE25-1-XSC	565	675
CE25-2-XSC	565	890
CE25-3-XSC	565	1100



Suction opening

- 4.** Determine the position of the suction opening.
Line up the hole and cut it out
(diameter, see the technical details on page 16).
- 5.** Drill the rivet holes for the collar.
Apply adhesive and fix the collar with rivets.
- 6.** Mount the (optional) Extraction Kit II
or fit the pipework.

! ATTENTION:
The maximum length of the suction hose or suction pipe must not exceed 3 m. The diameter of the suction hose or suction pipe must correspond to the diameter of the air intake.

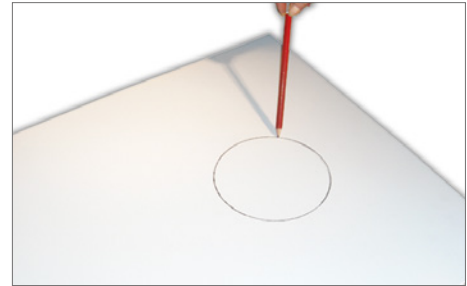

Fig.: Installation example with Extraction Kit II



Connection of the drain pipes

7. **!** *The connections to the device must be sealed airtight in order to ensure the perfect function of the separator.*

For this purpose, a syphon or drain line with an airtight end in a collecting tank can be connected, for example.

Connection of a hose/simple tubing

When using a simple pipe-and-hose drain, make sure that the vertical length, i. e. the difference in height between the housing socket and the end of the hose must be at least 300 mm.



Connection for liquid drain hose,
order no. 90 - 0 65 94



Liquid drain hose,
order no. 90 - 0 66 96

! ATTENTION:

The return line must have a diameter of 1/2 inch at least.

Connection of a siphon

The dimensioning of the siphon with respect to the sizes specified for a and b is described below:

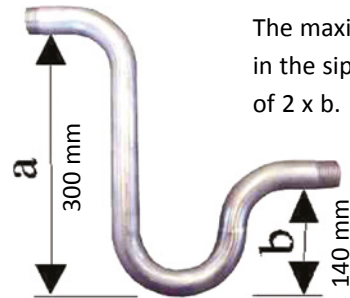

The maximum oil column in the siphon has a height of 2 x b.



Siphon,
order. no. 90 - 0 66 01

! ATTENTION:

Before putting the device into operation, fill the siphon, the hose and/or the collecting vessel with the cooling lubricant (cooling liquid) to be used to ensure their airtight closure.



If the siphon or hose is not filled with liquid as specified, the liquid level at the bottom of the housing will rise to an unacceptable high level, thereby having a negative effect on the separation performance and the high-voltage supply of the precipitators.



Incorrectly connected drain lines

! ATTENTION:

Never connect the liquid drains to each other.

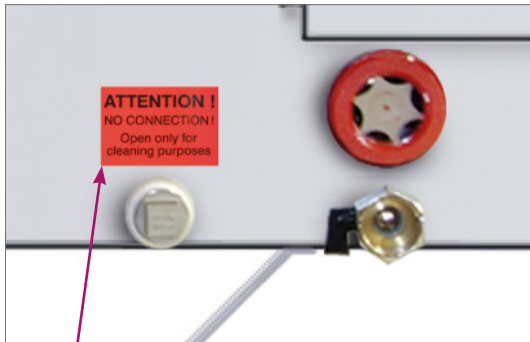

The left socket *may only be opened to clean* the fan chamber and must be closed afterwards (see page 29).

ATTENTION !
NO CONNECTION !
Open only for
cleaning purposes

! ATTENTION:

Never connect them horizontally.





Detailed Description of the Device and its Functions I

Details of the Device

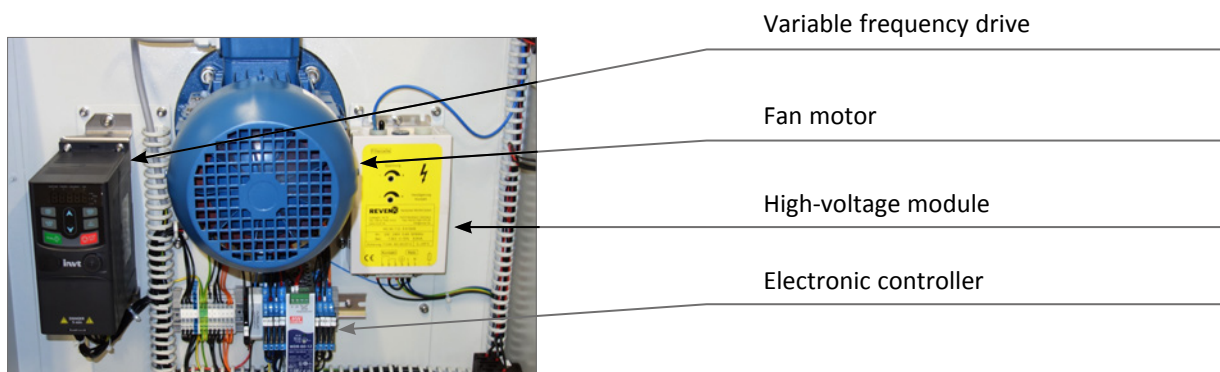
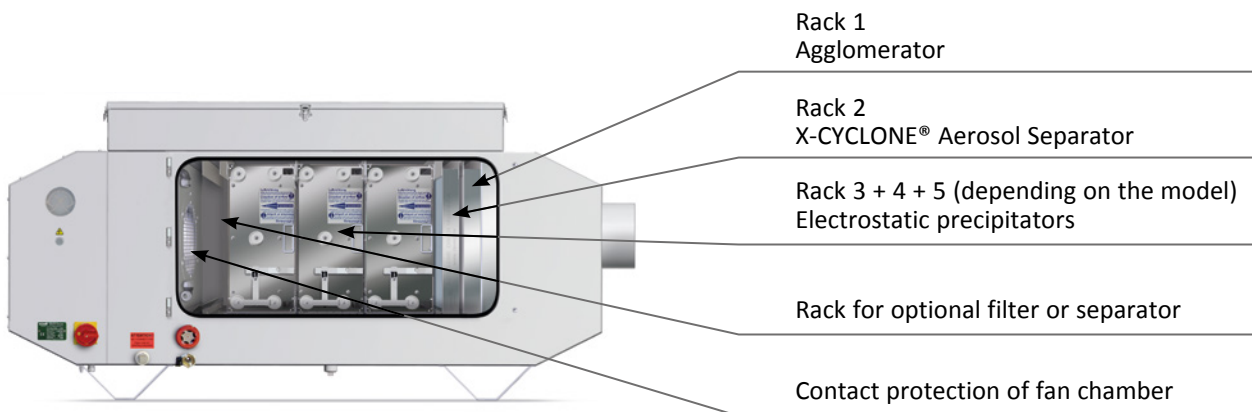
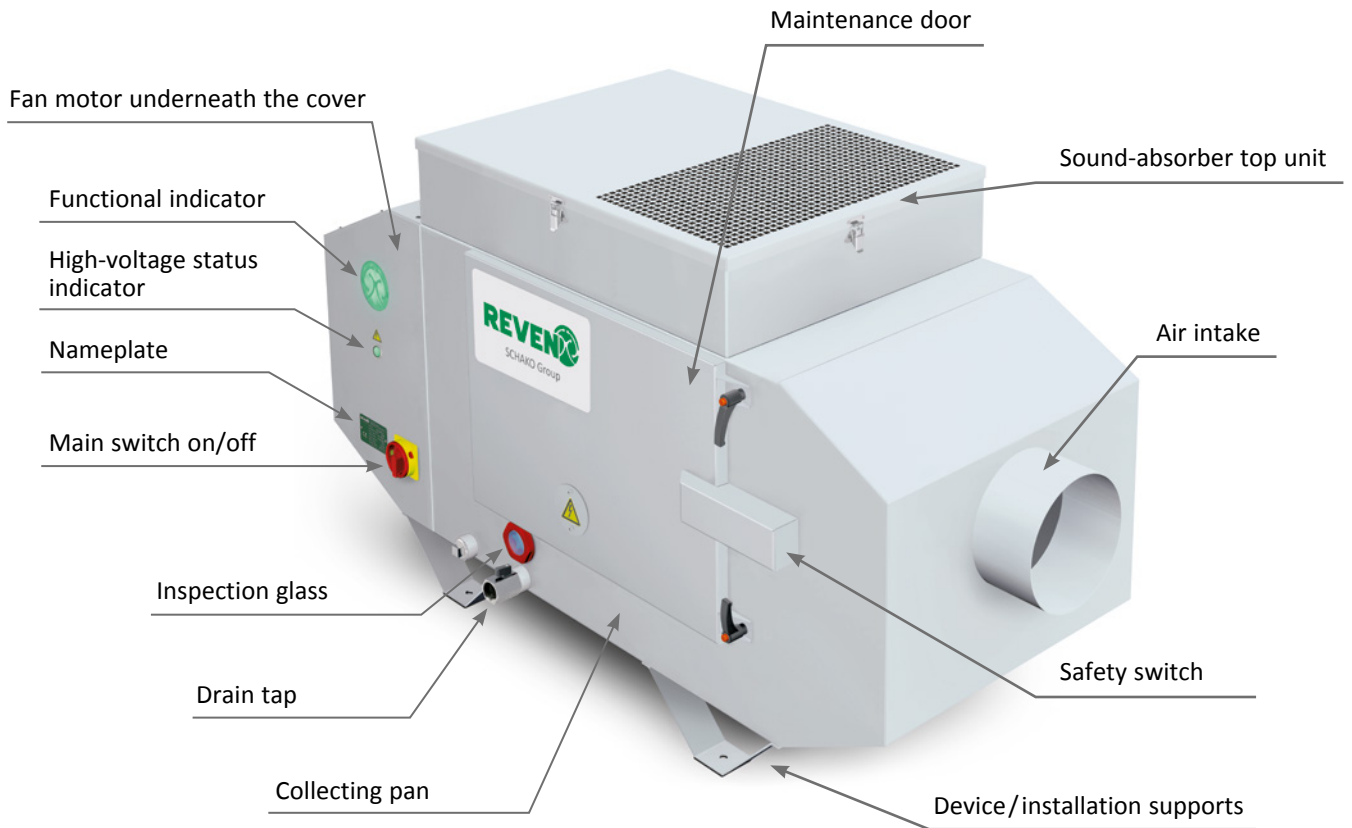



Detailed Description of the Device and its Functions II

Variable frequency drive

The X-CYCLONE® CR-XSC devices are fitted with a modern variable frequency drive. The variable frequency drive offers plug-and-play options providing for fast commissioning, maximum flexibility and a lead in competition.



Functional indicator

An LED indicates the degree of contamination of the separator and the agglomerator:

- Green:** In operation, separator/agglomerator in good condition.
- Yellow:** Cleaning required
- Red:** Cleaning mandatory, malfunction of the variable frequency drive



High-voltage status indicator

A small LED indicates the operational status of the high-voltage module:

- Green:** High voltage is supplied.
- Red:** Malfunction





Detailed Description of the Device and its Functions III

High-voltage module

The required high-voltage has been pre-set and measured at the factory.

! ATTENTION:
Any modification of the high-voltage settings is not permitted and will result in a reduced function or the total failure of the module.

! ATTENTION:
Consult the REVEN aftersales service before changing any settings of these potentiometers.

Fine adjustment



Fine-wire fuse



Order of the filter elements

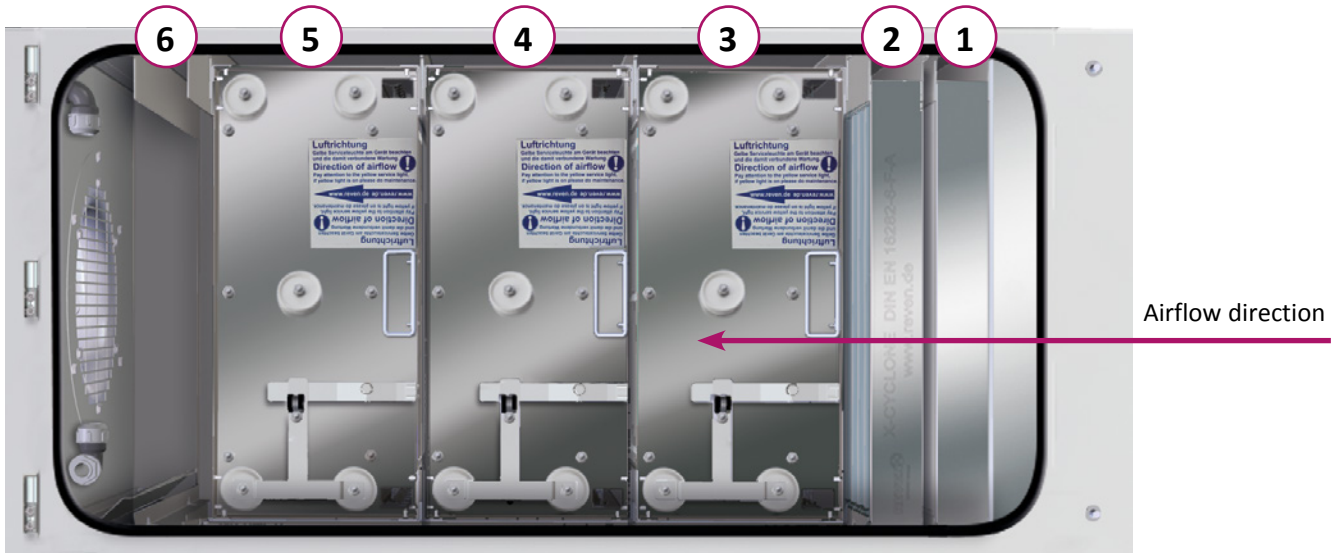

Fig.: X-CYCLONE® CE17-3-XSC with three precipitators, an aerosol separator with tested flame-arresting capability, and an agglomerator.

In general, X-CYCLONE® CE-XSC devices are fitted with the following separator and filter elements:

- Stage 1: Agglomerator
- Stage 2: X-CYCLONE® Aerosol Separator
- Stage 3: Electrostatic precipitator (simplex system)
- Stage 4: Electrostatic precipitator (duplex system)
- Stage 5: Electrostatic precipitator (triplex system)
- Stage 6: Available for optional filter or separator



Detailed Description of the Device and its Functions V

X-CYCLONE® Aerosol Separator

The patented X-CYCLONE® Aerosol Separators made by Rentschler REVEN are capable of separating particles of any size down to 0.01 µm with a very high degree of efficiency (oil and emulsion mists).

! ATTENTION:

Gaseous substances cannot be separated, however.

The *flame-arresting capability* of the X-CYCLONE® Aerosol Separator has been tested and confirmed by the German TÜV.

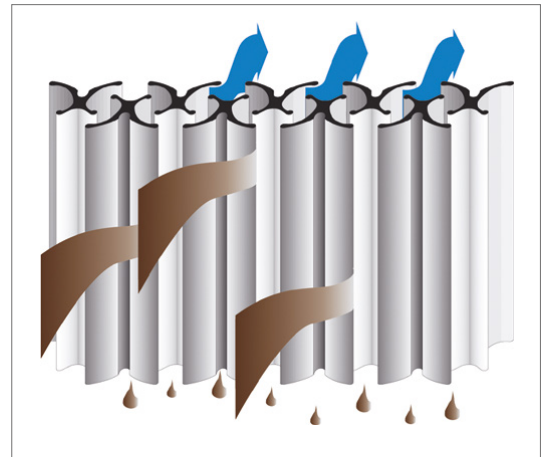

Fig.: Schematic representation of how the X-CYCLONE® Aerosol Separator works

! Observe the installation position!

! ATTENTION:

REVEN® devices must not be used when toxic substances are to be extracted in inadmissibly high concentrations.



Electrostatic precipitators

The function of the precipitators in the X-CYCLONE® CE-XSC devices can generally be described as follows. The ionisation wires and every second collection plate are under a positive high-voltage of 6 kV to 7 kV. The remaining collection plates and the frame of the precipitator are earthed, i. e. they are electrostatically neutral. The current flow is low as it is limited to the so-called ionisation current, which flows from the positive plates and ionisation wires to the earthed collection plates and housing parts. However, its magnitude must be taken into account, as the current flow passes through the air and produces ozone. In general, we can say that the higher the applied voltage the greater the current flow and, as a consequence, the quantity of ozone that is produced. We would be pleased to make detailed measuring protocols and test reports available to you on request.

When particles enter the electrostatic precipitators they give up electrons due to the positive charge of the ionisation wires and become positive themselves. The particles with the positive charge are then attracted by the neutral collection plates where they are neutralised and separated. There are also particle molecules with a high negative charge in the extracted air. Their negative charge cannot be neutralised completely through the positively charged ionisation wires, i. e. these molecules still have a negative charge downstream of the ionisation wires. Consequently, they are attracted by the positive collection plates and are separated there.

You can see from this short description that the separation process in an electrostatic precipitator is influenced by many parameters:



- Design of the ionisation wires
- Distance between the collection plates
- Risk of ozone generation
- Size of the effective collection surface
- Recovery time of the electrostatic field after a voltage flashover
- Energy consumption of the high-voltage modules

Intensive testing and measuring work based on the above-mentioned parameters revealed that the high-voltage level of 6 kV to 7 kV that we selected and use at present produces a minimum of ozone, provides for a recovery of the high-voltage module within a few milliseconds, and keeps the energy consumption at 120 W maximum.

If you are interested in further details or research results, please contact us or our technical field service.

REVEN® Precipitator



-  positive electrostatic charge
-  negative electrical charge



Technical Data

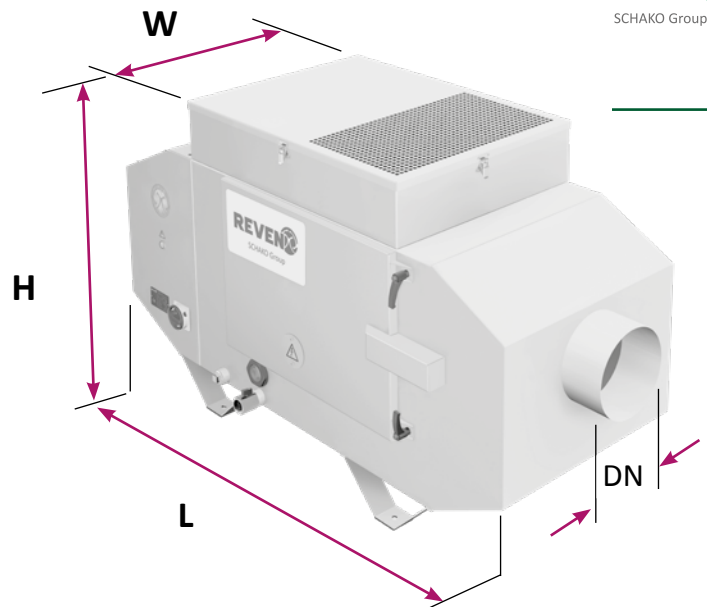

X-CYCLONE® CE-XSC series

Type of device X-CYCLONE®	Airflow rate in m ³ /h		Precipita- tor	Length L in mm	Width W in mm	Height H in mm	Connection DN in mm	Weight in kg (approx.)
	1*	2*						
CE10-1-XSC	1000	1500	1	1335	560	810	200	117
CE10-2-XSC	1000	1500	2	1540	560	810	200	143
CE10-3-XSC	1000	1500	3	1755	560	810	200	169
CE17-1-XSC	1700	2600	1	1375	525	900	200	121
CE17-2-XSC	1700	2600	2	1590	525	900	200	148
CE17-3-XSC	1700	2600	3	1800	525	900	200	175
CE25-1-XSC	2500	4500	1	1375	650	900	300	150
CE25-2-XSC	2500	4500	2	1590	650	900	300	185
CE25-3-XSC	2500	4500	3	1800	650	900	300	219

1* Airflow rate when connected to the extraction system with two filters installed.

2* Airflow rate in the unconnected, free-blowing state without filter(s).

Type of device X-CYCLONE®	Voltage U in Volt*		Current I in Ampere		Power P in Watt		Noise level in dB(A)**
	50 Hz	60 Hz	50 Hz	60 Hz	50 Hz	60 Hz	
CE10-1-XSC	3~400	3~460	0.60	0.60	357	411	65
CE10-2-XSC	3~400	3~460	0.60	0.60	357	411	65
CE10-3-XSC	3~400	3~460	0.60	0.60	357	411	65
CE17-1-XSC	3~400	3~460	1.05	1.05	611	703	67
CE17-2-XSC	3~400	3~460	1.05	1.05	611	703	67
CE17-3-XSC	3~400	3~460	1.05	1.05	611	703	67
CE25-1-XSC	3~400	3~460	1.99	1.99	1213	1395	70
CE25-2-XSC	3~400	3~460	1.99	1.99	1213	1395	70
CE25-3-XSC	3~400	3~460	1.99	1.99	1213	1395	70

* **ATTENTION: Ensure operation at the voltage indicated on the nameplate!** Performance data refer to the operating power.
Any other voltage will cause the destruction of the fan!
Versions with other voltages on request!

** Measured with medium fan load at a distance of 1 m from a device fitted with a sound-absorber top unit (included in the standard scope of delivery).

! Permissible ambient temperature for all types: 0 °C to 40 °C



General notices

Any work on electrical components/units may only be carried out by **electrically skilled personnel** and must comply with applicable regulations. Moreover, the contracting or operating company must ensure that the electrical installations and the electrical equipment are operated and maintained in compliance with applicable regulations. Before commencing any work on electrical components/units, make sure that you separate the device from its power supply and secure it against unintentional activation.

Our devices are wired ready for connection and their compliance with safety regulations was tested prior to the delivery. They comply with VDE directives.

! ATTENTION:

The air cleaner X-CYCLONE® C-XSC must be connected to the local equipotential bonding system. Local lines must be secured against overload and short-circuits.

- Observe the direction of rotation!
- The electrical connection is established via the terminals: terminal 1, terminal 2, terminal 3 , PE
Conductor assignment:
L1-conductor 1, L2-conductor 2, L3-conductor 3 and PE-PE
(optionally, Start/Stop via terminal 5 and terminal 6)
A suitable supply line shall be laid by the customer.
- When you upgrade the device with optional accessories, make sure that the supply line disposes of a neutral phase!
- Please observe the Circuit Diagram on page 21.

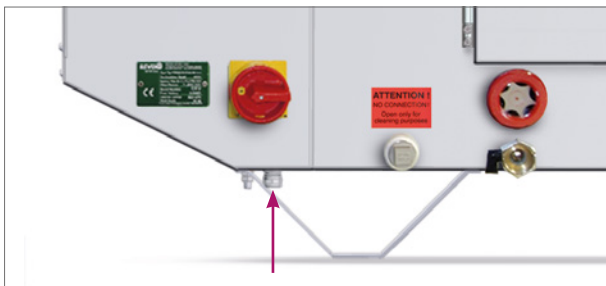

Fig.: Threaded cable connection for electrical supply line

Observe and check the direction of rotation of the fan

The shape and direction of rotation of the fan ensure that the air is drawn through the air intake.

The fan always rotates anti-clockwise (pre-set on the variable frequency drive in the factory)!

An incorrect direction of rotation causes a considerably reduced performance of the device and can permanently damage the fan motor.

! ATTENTION:

Our guarantee does not cover an incorrect connection of the fan!

Check the direction of rotation of the fan by following the notices on the sticker shown in the illustration.

To check the direction remove the housing lid and the sound-absorbing mat.



Wear protective glasses!

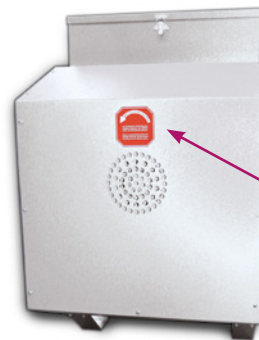

! ATTENTION:

Never use any rigid tools such as scrapers or screw drivers to clean the fan – risk of damage!



How to proceed when the functional indicator indicates a malfunction

To protect the X-CYCLONE® CE-XSC Air Cleaner, it is fitted with a variable frequency drive.

This drive protects the motor against short-circuit current and overcurrent. If the functional indicator turns red and starts flashing or the device shuts off there is a malfunction of the variable frequency drive.

Please observe the steps below for trouble-shooting:

1. Switch the device off on the main switch and separate it from power supply.
2. Wait for 10 seconds.
3. Remove the motor cover.
4. Reconnect the device to the supply mains and switch it on via the main switch.
5. Check the error code indicated on the display of the variable frequency drive.
! *Contact Rentschler REVEN.
If you need to change parameters do this only in coordination with your contact person at Rentschler REVEN.*
6. Switch the device off on the main switch and separate it from power supply.
7. Wait for 10 seconds.
8. Re-install the motor cover.
9. Reconnect the device to the supply mains and switch it on via the main switch.

! **ATTENTION:**
Any electrical work on the device or the supply cables shall only be carried out by electrically skilled personnel.

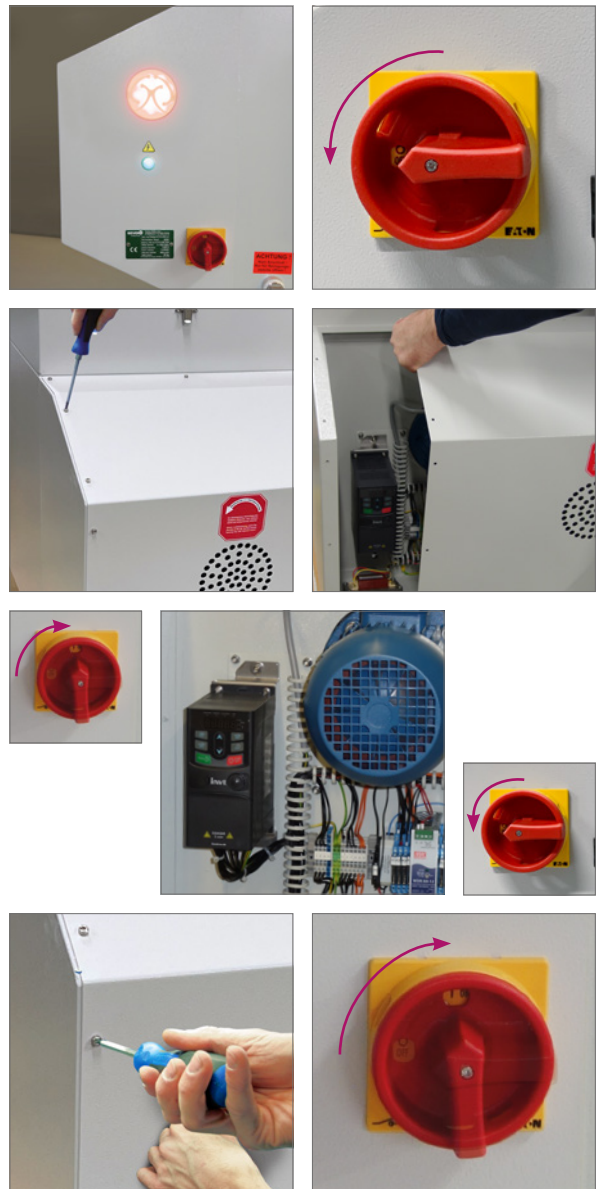



Troubleshooting

Malfunction	Cause	Remedy
The device does not run, the signal lamps are off.	The power supply was interrupted.	Check electrical connections. Check the fuse.
The functional indicator is lit red and the device does not run.	The maintenance door is not or incorrectly locked.	Close and lock the maintenance door properly. (After switching the device off and on again the malfunction is no longer indicated).
	The safety switch is defective.	Check the safety switch.
	The motor was switched off by the thermal contact.	<ul style="list-style-type: none"> • Check the voltage supply (by specialist electrician) • The motor bearings are worn (motor must be replaced) • The extracted medium is too hot (let the device cool down). • When the media temperature permanently exceeds 50 °C, call Rentschler REVEN, phone: +49 7042 373-0.
<p>After a longer downtime (week-end), the device indicates a malfunction (functional indicator lights up red) after switching on.</p> <p>At the same time, voltage flashovers can be heard at short intervals.</p>	In this case, dust has accumulated on the collection plates due to the absence of the airflow.	Switch the device off for about 10 seconds and switch it on again. Repeat this procedure several times if required.
The high-voltage status indicator is lit red.	Malfunction	When high-voltage status indicator is lit red, call Rentschler REVEN, phone: +49 7042 373-0.



Variable frequency drive GD20 Open Loop Control Structure



Variable frequency drive Definition

A variable frequency drive is a current converter that generates an alternating voltage with variable frequency and amplitude from alternating voltage for the direct supply of electrical machines such as three-phase motors. Setpoints for frequency and amplitude of the output AC voltage are based on the requirements of the electrical machine and its current load.

Some variable frequency drives have additional sensor inputs to record status parameters of the electrical machine such as speed or the current angular position of the rotor.

Depending on the type of electrical machine, variable frequency drives can operate with both single-phase AC voltage and three-phase AC voltage and can also generate three-phase AC voltage from single-phase AC voltage to supply three-phase motors.

(Source: <https://de.wikipedia.org/> (translated from the German article "Frequenzumrichter"))

Simplified scheme

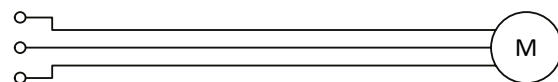

Constant speed

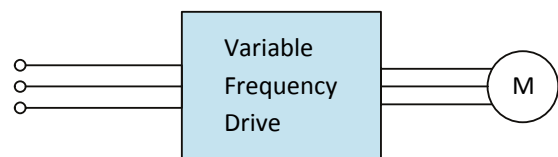

Variable speed

Additional functions (start-up/braking/current limiting)



Electrical Connection V

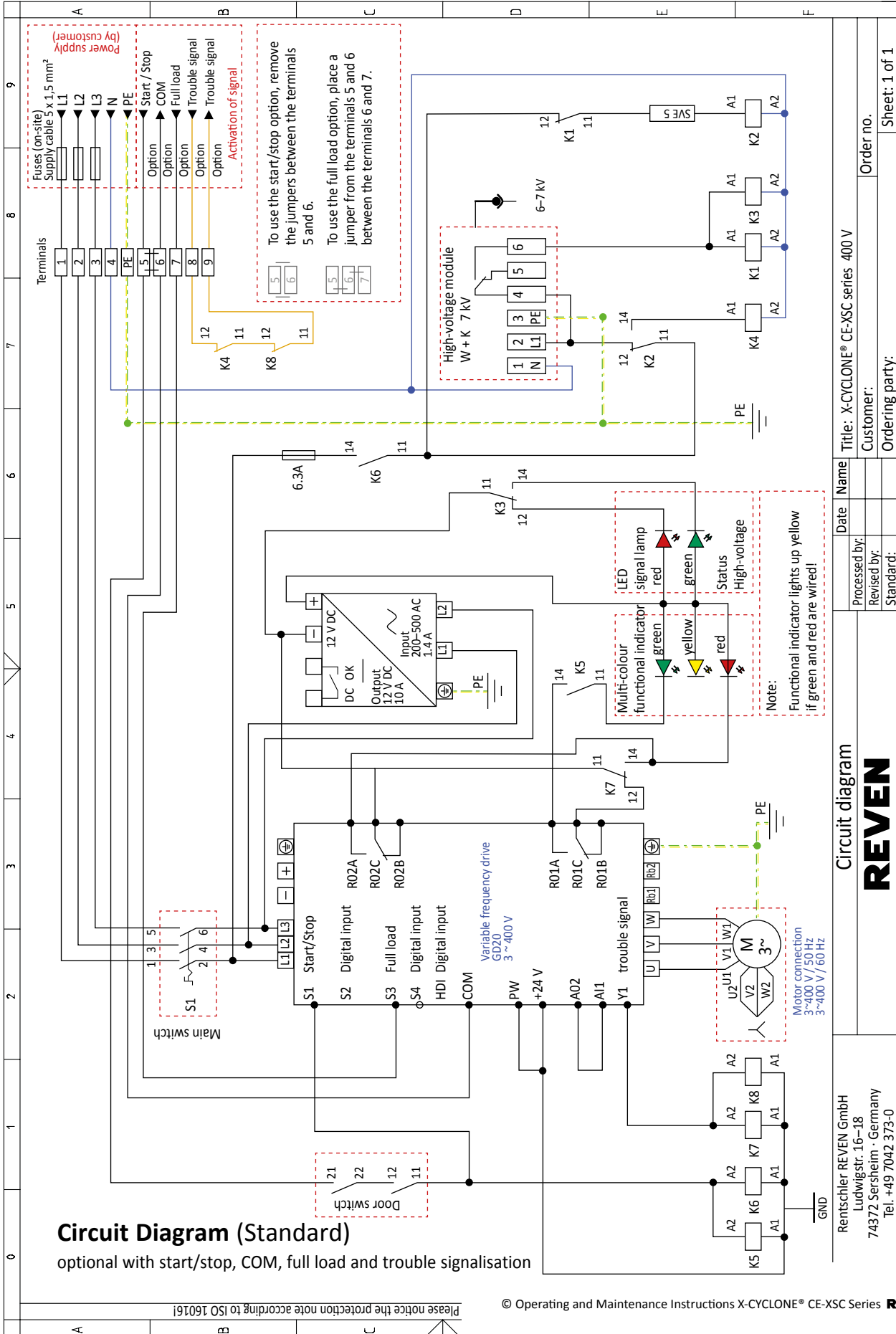



Cleaning and maintenance of the device

Cleaning and maintenance of the device should be carried out at regular intervals

- **to prevent the growth of harmful bacteria or fungi, and**
- to ensure the proper functioning and long service life of the unit.

(see the chapter "Cleaning and Maintenance VI" on page 31 and the following pages).

We recommend using a non-aggressive machine cleaning agent.

Spray it onto the housing parts and clean the device on the inside and outside with a suitable cloth or paper towel. Make sure that you dispose the auxiliaries and cleaning agents in accordance with statutory regulations on environmental protection and waste disposal.

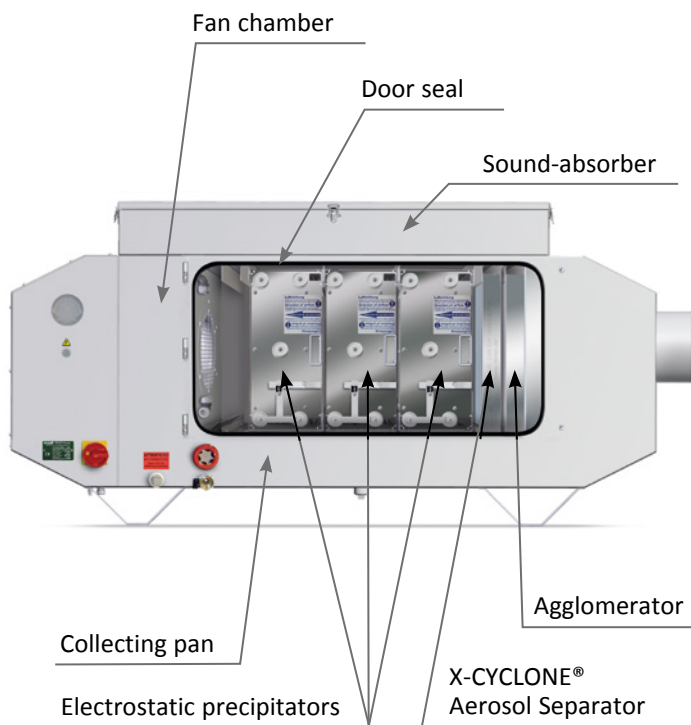

The cleaning and maintenance of the designated unit parts or inserts is explained individually on the following pages.

Legionella



Fig.: 3-D illustration of Legionella pneumophila bacteria

Legionella are bacteria that cause various states of disease in humans, ranging from flu-like symptoms to severe pneumonia ... in artificial water systems such as water pipes in buildings, the bacteria find good growth conditions at appropriate temperatures ... The pathogens are transmitted by atomised, vaporised water. The droplets containing the pathogen can spread in the air and be inhaled.

(Translation of excerpts from the article at: <https://www.infektionsschutz.de/erregersteckbriefe/legionellen>)

! *The use of water-miscible coolants and lubricants can result in the colonisation of legionella in ventilation systems of machine tools.*

In various types of filters, legionella can often find best possible growth conditions and, depending on the use of these filters, proliferate over time without being noticed. This may present a health hazard to the operating personnel.

For this reason, the separation and recirculation of coolant and lubricant aerosols is preferable to filtering and storage.

! ATTENTION:

To prevent the growth of legionella, clean the Air Cleaner and the pipes at least every six months and replace the filter if one is used.



Cleaning and maintenance of the precipitators

In order to ensure the perfect operation of the electrostatic precipitators in the long term, they should be inspected at least once a week and cleaned if necessary.

We recommend a complete service of the device and the precipitators every 3008 hours.

For this purpose, remove the precipitators from the device. (Observe the Safety Notices!) Clean them with machine cleaning agent or another appropriate fat dissolving agent.

Allow the cleaning agent to react for some time and then remove any dirt using a smooth brush or paintbrush. After that, rinse the precipitators thoroughly with clear water.

It is particularly important that you check whether all ionisation wires are clean and in place. They must not be sticky or incrustated. Make sure that the plates and ionisation wires are not damaged through mechanical action. If the plates and wires are severely contaminated, repeat the process if necessary.

Dry the precipitators with compressed air after cleaning. After reinserting the precipitators into the device, put the device into operation and let it run for approximately 10 min. before you switch the machine on.

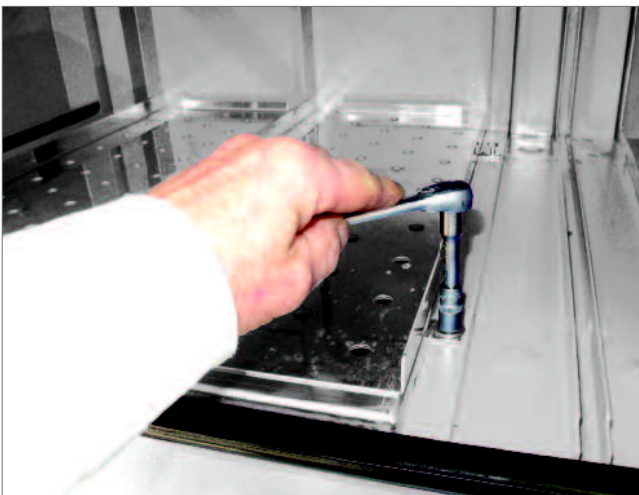

Fig.: The filter top and bottom can be removed for intense cleaning.

Reinstallation of the precipitators

When you insert the precipitators make sure that the air-flow direction arrow points towards the motor.



The plus bridge is always at the bottom.

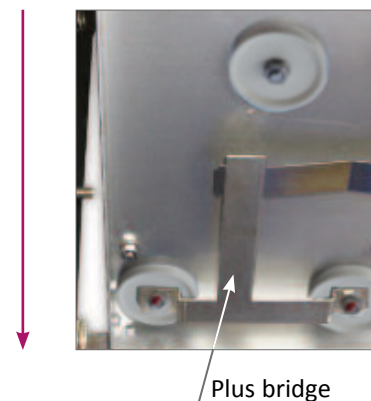



Cleaning and Maintenance III

Follow the steps below when cleaning of the precipitators

1.

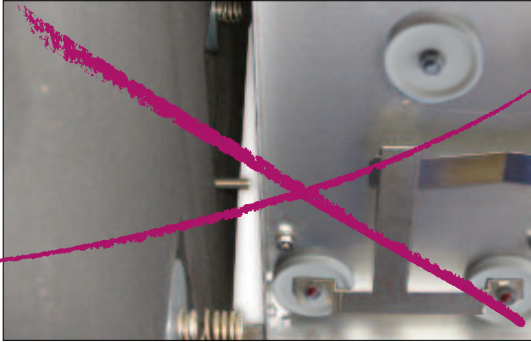

Be careful when extracting the precipitators!
The collection plates might be damaged.

2.

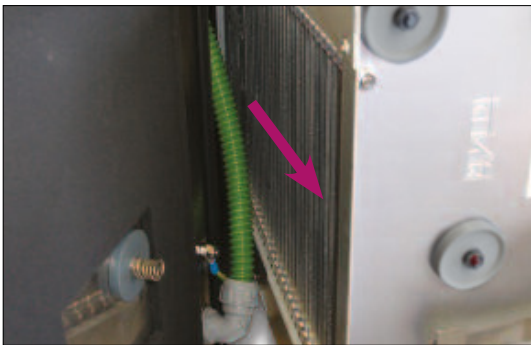

Handle the collector plates appropriately to avoid any damage.

3.

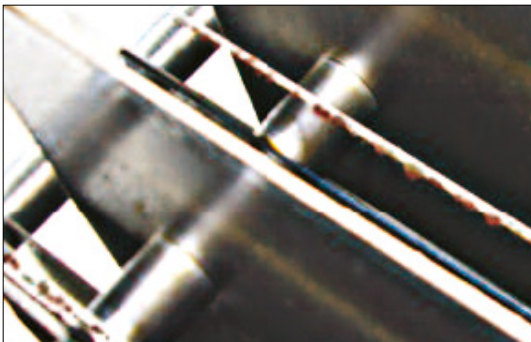

Illustration of contaminated collection plates and incrustated ionisation wires.

4.



Check also the cleanliness of the insulators.
Remove any dirt!

5.



Spray a suitable fat solvent onto all contaminations. We recommend using the biological oil remover "Oil-Free - V2000"

6.



Allow the agent to react for 10 minutes and clean the parts subsequently with a paintbrush.



Cleaning and Maintenance IV

7.

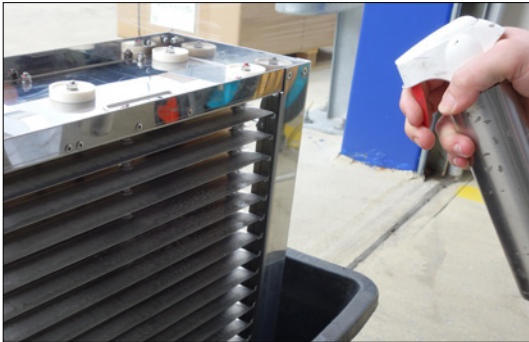

Apply the same cleaning procedure to the collection plates and ionisation wires.

8.



Let the cleaning agent act for 10 minutes and clean them with a smooth paintbrush.

9.



After cleaning the precipitator, rinse it well with clear water (*max. 30 °C*).

10.

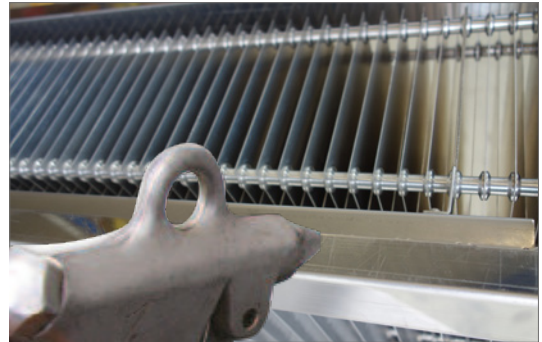

After cleaning and rinsing, dry the collector with compressed air.

Do not apply compressed air directly to the ionisation wires. This can damage them.

11.

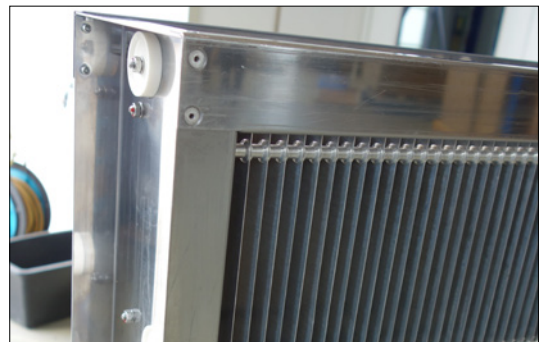

Make sure that the precipitators are dry before you reinsert them.

12.

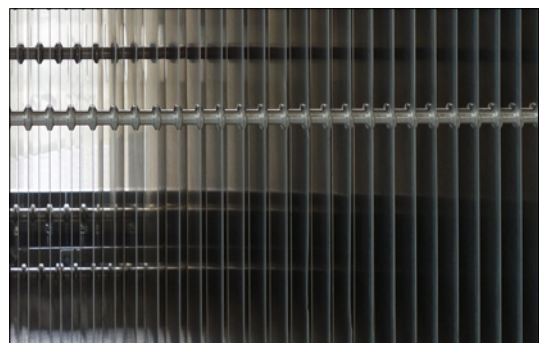

Before reinstalling the precipitator, check that all ionisation wires are in place.

Replace missing wires, otherwise the precipitator will not function properly.



Cleaning and Maintenance V

13.



Repeat cleaning if necessary. Spray cleaning agent onto the precipitator...

16.



Clean the filter tops and bottoms before reinserting the precipitators.

14.



...allow the agent to react...

17.

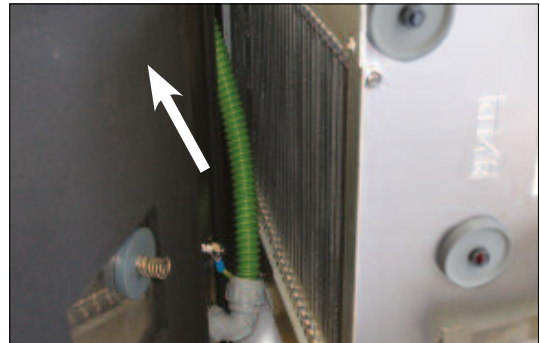

ATTENTION: Reinstall the precipitators carefully.
The collection plates might be damaged.

15.

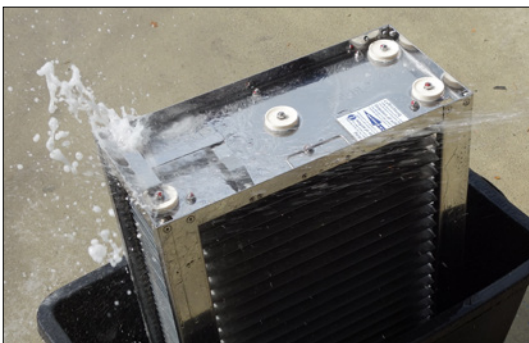

... and rinse (*max. 30 °C*).

18.

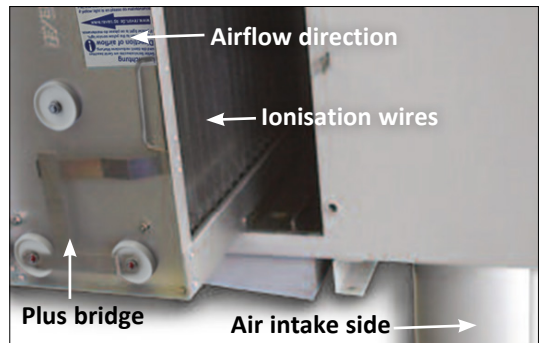

Observe the airflow direction! The ionisation wires should be on the intake side of the device!
The plus bridge should be at the bottom!

! ATTENTION:
After completion of the maintenance work, close the maintenance door and switch the device on. It should run for 10 minutes at least before you switch the machine on.



Cleaning and maintenance of the separator and the agglomerator

If the X-CYCLONE® Aerosol Separator or the agglomerator show strong contamination in the form of gumming or filter caking, they should be cleaned with the help of a high-pressure cleaner or an industrial washing machine. If the media to be separated constitute a biological or micro-biological hazard, because they form mildew cultures, viruses or bacteria, it is imperative that **regular maintenance and cleaning cycles be observed at short intervals.**

Follow the instructions below:

1. Switch off the device and separate it from its power supply before you open the maintenance door.
2. If substances that are hazardous to health are separated in the device, put on appropriate protective clothing before you open the maintenance door. **This helps to avoid burns, poisoning and/or caustic burns depending on the nature of the separated medium.**
3. Wait until the fan has stopped rotating before you open the maintenance door.
4. Open the maintenance door and extract the filter modules from the housing.
5. When reinstalling the separator and the agglomerator make sure that the modules are **correctly inserted** into the drainage receiver and that the **separator profiles are in a vertical position.**

! ATTENTION:

After completion of the maintenance work, close the maintenance door and switch the device on. It should run for 10 minutes at least before you switch the machine on.



Fig.: X-CYCLONE® Separator
observe the installation position!

Fig.: Agglomerator

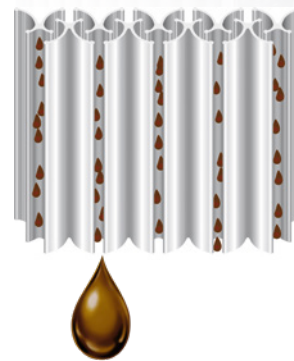

Fig.: Separated aerosols



Fig.: When installing the filter, the profiles must be arranged vertically.



Cleaning of the sound absorber

The sound-absorber unit, which is firmly attached to the device, can be removed by opening the four quick-release fasteners.

The sound-absorbing mat underneath the lid must be washed or replaced if required.

The sound-absorbing mat fulfils two different functions:

1. Soundproofing
2. The fan can eject condensed oil droplets. These are collected in the cellular plastic mat and can drip off.

! ATTENTION:
When reinstalling the sound-absorbing mat after cleaning, make sure that the exhaust air opening of the lid is opposite to that of the fan chamber.

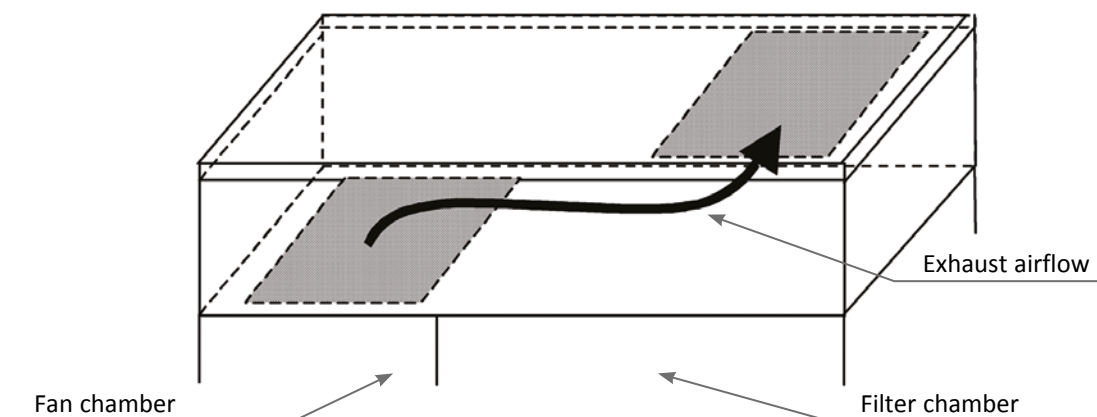
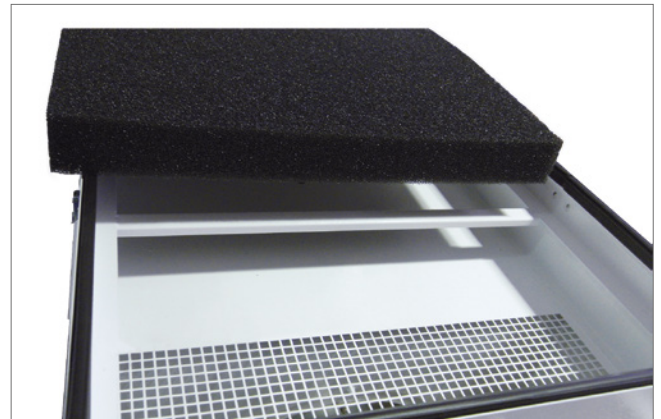



Checking the liquid level in the collecting pan

! ATTENTION:

At the latest when the liquid level is visible halfway up the inspection glass the coolant must be drained.

You should check the drain line or the siphon for clogging in this case.

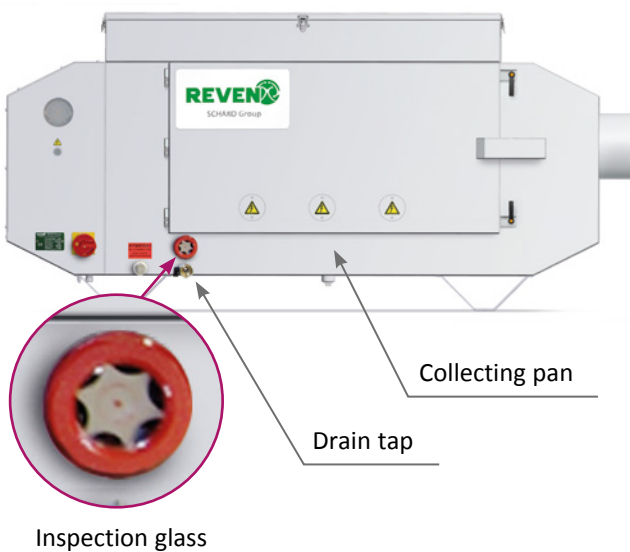

Cleaning the fan chamber

Check the cleanliness of the fan chamber during each maintenance operation. The cleanliness of the fan is of particular importance.

Incrustation on the fan blades will produce imbalance and might damage or even destroy the fan motor.

Remove strong incrustation with the help of a soft brush.

Remove the fan contact protection to clean the fan.

Spray a machine cleaning agent suitable for aluminium onto the impeller and brush the blades carefully

Repeat this process until the fan is clean.

! ATTENTION:

Never use any rigid tools such as scrapers or screw drivers to clean the fan – risk of damage!

Avoid any direct action of the cleaning agent on the fan motor!

Open the “cleaning socket” only when accumulated liquid needs to be drained. Close after cleaning.

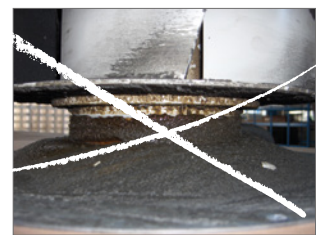
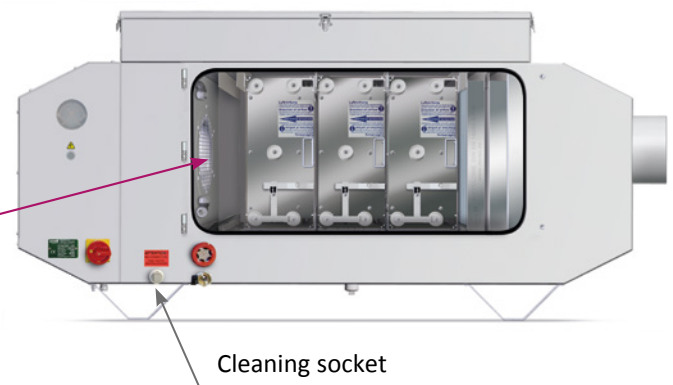

Fig.: View of the interior of a device that was not maintained



Checking the door seal

The door seal of the X-CYCLONE® CE-XSC devices is affected by ageing.

! *If any leakage, age hardening or damage becomes apparent, the door seal must be replaced.*

The door seal is fitted onto the frame section – and can easily be replaced!



Fig.: Remove the old seal



! ATTENTION:

The butt joint of the seal must always be on top. The three sealing lips should always face the side to be sealed (which is the housing interior).

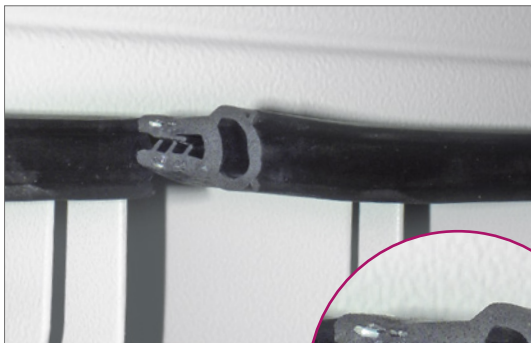

Fig.: Fit the new seal



Completing the maintenance work

After you have finished all maintenance work, reinstall the contact protection of the fan chamber and close the maintenance door.

! ATTENTION:

The device must never be operated when the maintenance door is open.

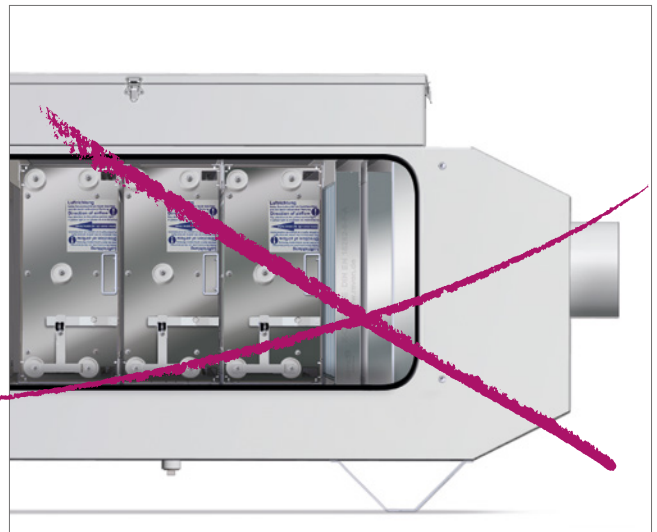

! ATTENTION:

After completion of the maintenance work, close the maintenance door and switch the device on. It should run for 10 minutes at least before you switch the machine on.

! ATTENTION:

The use of any parts other than the original ones will result in the termination of our warranty and functional guarantee for the device.



Cleaning and Maintenance X

Inspection point	Case of application	Maintenance interval					
		1 week after commissioning	Once a week	Every 6 months	Every 12 months	Every 24 months	Every 60 months
Drain facilities	- Leakage	O	O				
	- Drain coolant from the collecting pan - Clean the collecting pan			O			
Safety devices	- Fan contact protection installed - Safety sticker - Main switch o.k. - Safety switch o.k.		O				
Air intake / suction line	- Check for leakage	O	O				
Housing	- Check for contamination Clean if necessary	O	O				
	- Clean housing			O			
Fan chamber / fan	- Check for contamination Clean if necessary	O					
	- Clean fan / fan chamber			O			
Agglomerator / aerosol separator	- Clean agglomerator, separator			O			
Door seal	- Check for tightness and damage			O			
	- Replace seal						O
Sound-absorbing mat	- Clean the sound-absorbing mat			O			
	- Check for contamination and replace if necessary					O	
	- Replace sound-absorbing mat						O
Safety testing	- Test electrical protective conductors				O		
Precipitator unit	- Check for contamination and clean if necessary	O	O	O			

! ATTENTION:

The use of any parts other than the original ones will result in the termination of our warranty and functional guarantee for the device.



Cleaning and Maintenance XI

Inspection point	Operating hours	Inspected on date/signature	Inspected on date/signature
Precipitator unit			
Drain facilities			
Safety devices			
Suction line			
Housing			
Fan chamber/ fan			
Agglomerator/ aerosol separator			
Door seal			
Sound-absorbing mat			
Safety testing			



Cleaning and Maintenance XII

Inspection point	Operating hours	Inspected on date/signature	Inspected on date/signature
Precipitator unit			
Drain facilities			
Safety devices			
Suction line			
Housing			
Fan chamber/ fan			
Agglomerator/ aerosol separator			
Door seal			
Sound-absorbing mat			
Safety testing			



Cleaning and Maintenance XIII

Inspection point	Operating hours	Inspected on date/signature	Inspected on date/signature
Precipitator unit			
Drain facilities			
Safety devices			
Suction line			
Housing			
Fan chamber/ fan			
Agglomerator/ aerosol separator			
Door seal			
Sound-absorbing mat			
Safety testing			



Spare Parts List I

Item no.	Designation	Suitable for	Order no.
1	Fan motor	X-CYCLONE® CE10-1-XSC X-CYCLONE® CE10-2-XSC X-CYCLONE® CE10-3-XSC	90 - 3 02 01
2	Fan motor	X-CYCLONE® CE17-1-XSC X-CYCLONE® CE17-2-XSC X-CYCLONE® CE17-3-XSC	90 - 3 03 05
3	Fan motor	X-CYCLONE® CE25-1-XSC X-CYCLONE® CE25-2-XSC X-CYCLONE® CE25-3-XSC	90 - 3 02 04
4	X-CYCLONE® Aerosol Separator, 490 x 375 x 50 mm	X-CYCLONE® CE10-1-XSC X-CYCLONE® CE10-2-XSC X-CYCLONE® CE10-3-XSC	90 - 0 61 21
5	X-CYCLONE® Aerosol Separator, 450 x 460 x 50 mm	X-CYCLONE® CE17-1-XSC X-CYCLONE® CE17-2-XSC X-CYCLONE® CE17-3-XSC	90 - 0 61 22
6	X-CYCLONE® Aerosol Separator, 570 x 460 x 50 mm	X-CYCLONE® CE25-1-XSC X-CYCLONE® CE25-2-XSC X-CYCLONE® CE25-3-XSC	90 - 0 61 23
7	Agglomerator, 490 x 375 x 50 mm	X-CYCLONE® CE10-1-XSC X-CYCLONE® CE10-2-XSC X-CYCLONE® CE10-3-XSC	90 - 0 63 38
8	Agglomerator, 450 x 460 x 50 mm	X-CYCLONE® CE17-1-XSC X-CYCLONE® CE17-2-XSC X-CYCLONE® CE17-3-XSC	90 - 0 63 39
9	Agglomerator, 570 x 460 x 50 mm	X-CYCLONE® CE25-1-XSC X-CYCLONE® CE25-2-XSC X-CYCLONE® CE25-3-XSC	90 - 0 63 40
10	Ionisation wire + spring	X-CYCLONE® CE10-1-XSC X-CYCLONE® CE10-2-XSC X-CYCLONE® CE10-3-XSC	65 - 5 40 30
11	Ionisation wire + spring	X-CYCLONE® CE17-1-XSC X-CYCLONE® CE17-2-XSC X-CYCLONE® CE17-3-XSC	65 - 5 42 30
12	Ionisation wire + spring	X-CYCLONE® CE25-1-XSC X-CYCLONE® CE25-2-XSC X-CYCLONE® CE25-3-XSC	65 - 5 44 30
13	Insulator for the precipitator of new series, round design	all types	90 - 2 00 31
14	Sound-absorbing mat	X-CYCLONE® CE10-1-XSC	90 - 3 50 20
15	Sound-absorbing mat	X-CYCLONE® CE10-2-XSC	90 - 3 50 21
16	Sound-absorbing mat	X-CYCLONE® CE10-3-XSC	90 - 3 50 26
17	Sound-absorbing mat	X-CYCLONE® CE17-1-XSC	90 - 3 50 22
18	Sound-absorbing mat	X-CYCLONE® CE17-2-XSC	90 - 3 50 27



Spare Parts List II

Item no.	Designation	Suitable for	Order no.
19	Sound-absorbing mat	X-CYCLONE® CE17-3-XSC	90 - 3 50 23
20	Sound-absorbing mat	X-CYCLONE® CE25-1-XSC	90 - 3 50 24
21	Sound-absorbing mat	X-CYCLONE® CE25-2-XSC	90 - 3 50 28
22	Sound-absorbing mat	X-CYCLONE® CE25-3-XSC	90 - 3 50 25
23	Door sealing mat, self-adhesive on one side	X-CYCLONE® CE10-1-XSC	90 - 3 50 70
24	Door sealing mat, self-adhesive on one side	X-CYCLONE® CE10-2-XSC	90 - 3 50 71
25	Door sealing mat, self-adhesive on one side	X-CYCLONE® CE10-3-XSC	90 - 3 50 76
26	Door sealing mat, self-adhesive on one side	X-CYCLONE® CE17-1-XSC	90 - 3 50 72
27	Door sealing mat, self-adhesive on one side	X-CYCLONE® CE17-2-XSC	90 - 3 50 77
28	Door sealing mat, self-adhesive on one side	X-CYCLONE® CE17-3-XSC	90 - 3 50 73
29	Door sealing mat, self-adhesive on one side	X-CYCLONE® CE25-1-XSC	90 - 3 50 74
30	Door sealing mat, self-adhesive on one side	X-CYCLONE® CE25-2-XSC	90 - 3 50 78
31	Door sealing mat, self-adhesive on one side	X-CYCLONE® CE25-3-XSC	90 - 3 50 75
32	Inspection glass	all types	60 - 0 65 81
33	Full perimeter door seal, by the meter	all types	90 - 1 00 41
34	Variable frequency drive GD20, 0.75 kW	X-CYCLONE® CE10-1-XSC X-CYCLONE® CE10-2-XSC X-CYCLONE® CE10-3-XSC X-CYCLONE® CE17-1-XSC X-CYCLONE® CE17-2-XSC X-CYCLONE® CE17-3-XSC	90 - 3 04 52
35	Variable frequency drive GD20, 1.5 kW	X-CYCLONE® CE25-1-XSC X-CYCLONE® CE25-2-XSC X-CYCLONE® CE25-3-XSC	90 - 3 04 53
36	Functional indicator (LED) = round, Ø 8 cm	all types	90 - 0 87 80
37	High-voltage status indicator (LED) for the high-voltage module	all types	90 - 0 87 82
38	Power supply unit, DIN-rail, WDR-120-12	all types	90 - 0 87 81
39	High-voltage module, version 2013	all types	90 - 2 00 04



Spare Parts List III

Item no.	Designation	Suitable for	Order no.
40	Relais, 24 V	all types	90 - 2 30 43
41	X-CYCLONE® Extraction Kit II, DN 200, 2 m extraction hose, 2 pcs. hose clamps	X-CYCLONE® CE10-1-XSC X-CYCLONE® CE10-2-XSC X-CYCLONE® CE10-3-XSC X-CYCLONE® CE17-1-XSC X-CYCLONE® CE17-2-XSC X-CYCLONE® CE17-3-XSC	60 - 1 04 02
42	X-CYCLONE® Extraction Kit II, DN 300, 2 m extraction hose, 2 pcs. hose clamps	X-CYCLONE® CE25-1-XSC X-CYCLONE® CE25-2-XSC X-CYCLONE® CE25-3-XSC	60 - 1 04 03
43	X-CYCLONE® Extraction Kit III, Stand with a height of 1 to 2 m, extraction hose*	X-CYCLONE® CE10-1-XSC	90 - 3 60 20
44	X-CYCLONE® Extraction Kit III, Stand with a height of 1 to 2 m, extraction hose*	X-CYCLONE® CE10-2-XSC	90 - 3 60 21
45	X-CYCLONE® Extraction Kit III, Stand with a height of 1 to 2 m, extraction hose*	X-CYCLONE® CE10-3-XSC	90 - 3 60 26
46	X-CYCLONE® Extraction Kit III, Stand with a height of 1 to 2 m, extraction hose*	X-CYCLONE® CE17-1-XSC	90 - 3 60 22
47	X-CYCLONE® Extraction Kit III, Stand with a height of 1 to 2 m, extraction hose*	X-CYCLONE® CE17-2-XSC	90 - 3 60 27
48	X-CYCLONE® Extraction Kit III, Stand with a height of 1 to 2 m, extraction hose*	X-CYCLONE® CE17-3-XSC	90 - 3 60 23
49	X-CYCLONE® Extraction Kit III, Stand with a height of 1 to 2 m, extraction hose*	X-CYCLONE® CE25-1-XSC	90 - 3 60 24
50	X-CYCLONE® Extraction Kit III, Stand with a height of 1 to 2 m, extraction hose*	X-CYCLONE® CE25-2-XSC	90 - 3 60 28
51	X-CYCLONE® Extraction Kit III, Stand with a height of 1 to 2 m, extraction hose*	X-CYCLONE® CE25-3-XSC	90 - 3 60 25
52	Main switch on/off	all types	90 - 0 87 42
53	Drain tab, 1 inch, male thread*	all types	90 - 0 66 18
54	Liquid hose, wall thickness 3 mm, inner \varnothing 19 mm*	all types	90 - 0 66 96
55	Hose connection adapter, 1 inch to 19 mm, male thread*	all types	90 - 0 65 94
56	Siphon, 1 inch, male thread*	all types	90 - 0 66 01
57	REVEN® Pipe 2, \varnothing 200 mm x length 400 mm*	X-CYCLONE® CE10-1-XSC X-CYCLONE® CE10-2-XSC X-CYCLONE® CE10-3-XSC X-CYCLONE® CE17-1-XSC X-CYCLONE® CE17-2-XSC X-CYCLONE® CE17-3-XSC	On request
58	REVEN® Pipe 3, \varnothing 300 mm x length 400 mm*	X-CYCLONE® CE25-1-XSC X-CYCLONE® CE25-2-XSC X-CYCLONE® CE25-3-XSC	On request



Spare Parts List IV

Item no.	Designation	Suitable for	Order no.
59	Stainless steel mesh insert, condenser, Ø 200 mm x length 150 mm*	X-CYCLONE® CE10-1-XSC X-CYCLONE® CE10-2-XSC X-CYCLONE® CE10-3-XSC X-CYCLONE® CE17-1-XSC X-CYCLONE® CE17-2-XSC X-CYCLONE® CE17-3-XSC	On request
60	Stainless steel mesh insert, condenser, Ø 300 mm x length 150 mm*	X-CYCLONE® CE25-1-XSC X-CYCLONE® CE25-2-XSC X-CYCLONE® CE25-3-XSC	On request
61	Particulate air filter top unit*	X-CYCLONE® CE10-1-XSC	65 - 5 40 15
62	Particulate air filter as spare*	X-CYCLONE® CE10-1-XSC	65 - 5 40 16
63	Particulate air filter top unit*	X-CYCLONE® CE10-2-XSC	65 - 5 41 15
64	Particulate air filter as spare*	X-CYCLONE® CE10-2-XSC	65 - 5 41 16
65	Particulate air filter top unit*	X-CYCLONE® CE10-3-XSC	65 - 5 41 80
66	Particulate air filter as spare*	X-CYCLONE® CE10-3-XSC	65 - 5 41 81
67	Particulate air filter top unit*	X-CYCLONE® CE17-1-XSC	65 - 5 42 15
68	Particulate air filter as spare*	X-CYCLONE® CE17-1-XSC	65 - 5 42 16
69	Particulate air filter top unit*	X-CYCLONE® CE17-2-XSC	65 - 5 42 80
70	Particulate air filter as spare*	X-CYCLONE® CE17-2-XSC	65 - 5 42 81
71	Particulate air filter top unit*	X-CYCLONE® CE17-3-XSC	65 - 5 43 15
72	Particulate air filter as spare*	X-CYCLONE® CE17-3-XSC	65 - 5 43 16
73	Particulate air filter top unit*	X-CYCLONE® CE25-1-XSC	65 - 5 44 15
74	Particulate air filter as spare*	X-CYCLONE® CE25-1-XSC	65 - 5 44 16
75	Particulate air filter top unit*	X-CYCLONE® CE25-2-XSC	65 - 5 44 80



Spare Parts List IV

Item no.	Designation	Suitable for	Order no.
76	Particulate air filter as spare*	X-CYCLONE® CE25-2-XSC	65 - 5 44 81
77	Particulate air filter top unit*	X-CYCLONE® CE25-3-XSC	65 - 5 45 15
78	Particulate air filter as spare*	X-CYCLONE® CE25-3-XSC	65 - 5 45 16
79	Electrostatic precipitator as spare*	X-CYCLONE® CE10-1-XSC X-CYCLONE® CE10-2-XSC X-CYCLONE® CE10-3-XSC	60 - 0 80 81
80	Electrostatic precipitator as spare*	X-CYCLONE® CE10-1-XSC X-CYCLONE® CE10-2-XSC X-CYCLONE® CE10-3-XSC	60 - 0 80 82
81	Electrostatic precipitator as spare*	X-CYCLONE® CE10-1-XSC X-CYCLONE® CE10-2-XSC X-CYCLONE® CE10-3-XSC	60 - 0 80 83

* Accessories not included in the scope of delivery.
Observe the instructions in the separate operating manual!

Infoline: +49 7042 373-25
+49 7042 373-33
+49 7042 373-36

Phone: +49 7042 373-0
www.reven.de



Particulate air filter top unit

High-performance after-filter for air extracted from processing operations running in oil and/or processes with high smoke generation.



REVEN® Pipe

For high oil and water vapour concentrations.



Manufacturer's Declaration

Declaration of Conformity in accordance with the standards

EC Machinery Directive 2006/42/EC and the
EU EMC Directive 2014/30/EU

We hereby declare that the design and construction of this device as delivered complies with the above-mentioned directives.

**Designation: X-CYCLONE® CE-XSC Models CE10-1-XSC, CE10-2-XSC, CE10-3-XSC,
CE17-1-XSC, CE17-2-XSC, CE17-3-XSC, CE25-1-XSC, CE25-2-XSC, CE25-3-XSC**

Order no.:

The following harmonised DIN EN standards apply in accordance with the official journals of the directives:

Directive/Standard		Title
DIN EN 82079-1	2013	Preparation of instructions for use – Structuring, content and presentation – Part 1: General principles and detailed requirements (IEC 82079-1:2012)

2014/30/EU		EU Directive: EMC valid from 26 February 2014
DIN EN 61000-6-2	2005 + AC: 2005	Electromagnetic compatibility (EMC) – Part 6-2: Generic standards – Immunity for industrial environments (IEC 61000-6-2:2005)
DIN EN 61000-6-4	2007 + A1: 2011	Electromagnetic compatibility (EMC) – Part 6-4: Generic standards – Emission standard for industrial environments (IEC 61000-6-4:2006 + A1:2010)

2006/42/EC		EU Directive: Machinery valid from 17 May 2006
DIN EN ISO 12100	2011	Safety of machinery – General principles for design – Risk assessment and risk reduction
DIN EN 60204-1	2006 + AC: 2010	Safety of machinery - Electrical equipment of machines – Part 1: General requirements
DIN EN ISO 13732-1	2006	Ergonomics of the thermal environment – Methods for the assessment of human responses to contact with surfaces – Part 1: Hot surfaces
DIN EN ISO 13850	2015	Safety of machinery – Emergency stop function – Principles for design
DIN EN 16282-8	2017-2	Equipment for commercial kitchens – Components for ventilation in commercial kitchens – Part 8: Installations for treatment of aerosol; Requirements and testing

In the standard DIN EN ISO 12100, reference is made to the following standards among others:
DIN EN 349; DIN EN 574; DIN EN 614-1; DIN-EN 842; DIN EN 981; DIN EN 894-1, -2, -3; DIN EN ISO 14118; DIN EN ISO 14119; DIN EN ISO 14123-1

! ATTENTION:

- This declaration refers exclusively to the machine in the condition in which it was placed on the market.
- The essential safety and health requirements specified in Annex I of the Machinery Directive 2006/42/EC have been implemented and are met.
- The special technical file as per Annex VII A has been compiled and will be transmitted electronically to the relevant national authority on request.
- Authorised person for the compilation of the technical documentation:
Klaus Mann, Ludwigstr. 16–18, 74372 Sersheim/Germany

Sersheim, (date)

Signature of the business manager
(Dipl.-Ing. Sven Rentschler, Managing Director)